



eatec[®]

we control
your comfort

general catalogue
2026

Company

Eatec srl was founded in **2012** through the collaboration of experts with many years of experience in the heating, ventilation, air-conditioning and refrigeration field.

We are paying constant attention to the needs of national and international markets. Eatec stands for its innovative and dynamic approach to its offer and for its great flexibility with which it approaches the market and adapts to specific customer needs. Thanks to

its long experience in the HVAC/R field, **Eatec** has successfully introduced new product lines, placing the company at excellent Italian and international standard.



Mission

We control your comfort summarizes effectively the principles and the values of the company's mission: quality, satisfaction, customer care and service, but also professionalism, dynamism, flexibility to adapt to every need and, above all, constant attention to markets and innovative products.

The customers' needs and benefits stay in the foreground when it comes to quality and partnership. Our value system towards the employees, customers and suppliers places human beings in the focus of the organization.

"I believe in strong teamwork and play to win"
(Elke de Biase, General Manager)

Index

page

redline

thermostats

TD	8
TAM	10
TA	12
TK	13
TI	14
TC	15
RTA02	16
RTA34	18
RTA37	20

violetline

flow switches

FS	24
FL	26
FL200	28
FLUS001	30
FLUS	32
FG	34
FSA	35

blueline

pressure switches

PA	38
MM	40

orangeline

damper actuators

S2	44
S4	46
S8	48
S16	51
S24	54
S32	57
S8F	60
S16F	63
SR2	66
SR3	68
SR5	70
SR10	72
SR15	74
SR20	76
ST3	78
ST5	80
ST10	82
ST15	84
ST20	86
SF10	88
SF15	90
SF30	92
SX	94
SRX	96

greenline

motorized valves

VB, SVB	100
AVC	102
AVS	104
VZ, SVZ	106
VS	108
S5..V	111
S10..V	114
VG	117
AVG6	119
AVG10	121
VGI	123
AVGI10	125
VGO	133
AVGO15	135
VF	143
AVF	145
AVF30	147
AVF70	149
VFF	151
AVFF	153
VFF250-300	163
AVFF65-100	165
VH	172
VM	173
Diagram of pressure losses for liquids	175

grayline

humidistats

HR1	178
HD1	180

yellowline

transmitters

KTI	184
KTO	189
KTD	194
KTP	199
KSIC	201
KSDC	206
KSAV	211
TTI	216
TTO	218
TTOM	220
TTD / TTS	222
TTDM / TTSM	224
TTHI	226
TTHO	228
TTHOM	230
TTHD	232
TTHDM	234
SAC	236
SACM	238
SAV	241
SACV	243
SDC	245
SDCM	247
SDV	249
SDVM	251
PTD	253
PTR	255
PTS	258
PTG	262
PTG / VTG	265
PTM	269
PTV	271
PTQ	274
KFSE	277
KSWL	284

cyanline

sensors

SC	290
SCT	291
SCK	292
STR	293
SA	294
SO	295
SZ	296
SM	298
Resistance characteristics of temperature sensors	300
General sales conditions	303

References

Discover some of the most important projects that **Eatec** has carried out together with its customers in Italy and around the world.



Cast Alimenti
BRESCIA



Centrali Telecom
ITALIA



Centro Snam
RAGUSA



Old Wild West
ITALIA



Palazzo Hyundai
MILANO



Linklaters
LONDON



LSG Skychefs, Lavaggio e Plonge
FIUMICINO



Università degli Studi
PESCARA



Hellenic Coast Guard
PIRAEUS



Sun City Resort
SOUTH AFRICA



Ipermercato Conad
FRASCATI



STMicroelectronics
AGRATE



Università Nicolò Cusano
ROMA



Centre Hospitalier du Sud Seine
et Marne a Fontainebleau
FRANCE



Medical diagnostic Center
KRASNODAR



Hospital South Gai Gon
VIETNAM



Türkan Villa Project
BAKU AZERBAIJAN



Regional Children's Clinical Hospital
TAMBOV



Agenzia delle Entrate
ROMA



SmartRoad 2021
ALEMAGNA "BELLUNO-CORTINA"



Kernkraftwerk Biblis
WORMS



Ospedale S. Andrea
ROMA



Amazon Logistics
VARESE, CATANIA, TORINO, PESCARA



Royal Caribbean International Fleet
MIAMI



Witor's Spa
GORIZIA



Kaufl and Stores
ROMANIA



Holiday Inn
MESTRE



Banca Sella
PALERMO



ATG Hand Care
SRI LANKA



Studentato Stonehill
BOLOGNA



Carrefour
CRACOVIA



Cigar Access
GREECE



Ipermercato Conad
VELLETRI



Carrefour
CRACOVIA



Presidio Ospedaliero Pini
MILANO



Quellenhof Luxury Resort
LAZISE



redline

thermostats

Description



The frost protection thermostat serie TD is suitable for the protection of hot-water heating registers, downstream air heaters in ventilation and climate control systems as well as heat exchangers in cooling systems. The thermostats can also be used to control electrical heating systems and to switch acoustic or optical alarm signals and measure temperature in non aggressive gases or liquid medium.

Technical specifications



Measurement range	-15...+15°C
Factory calibration	on 5°C, off 0°C
Differential	adjustable from 1 to 15° C
Electrical rating	8 A, 250 V AC
Reset	Automatic, the switching contact moves back to its normal position if temperature moves to normal range. Manual, the switching contact is moved back by pressing the reset button on the housing.
Sensibile element	Gas-filled copper capillary
Cable entry	Cable gland Ø 6...13 mm
Housing	Metal base with ABS cover
Wiring terminals	Screw terminals for wires of up to 1,5 mm ² cross-section
Cooling of capillary coil	The 3 and 6 m capillaries are sensitive over the entire length and detect, with a minimum length of 30 cm, a temperature change from the set point. The 1,8 m capillary is only sensitive on the bulb.
Max. overload temperature	150°C (max. 1 hour)
Dimensions	See drawing
Protection type	IP55
Protection class	I
Working range RH	5...95% RH, non-condensing
Working temperature °C	-20...+55°C
Storage temperature	-30...+60°C
Accessories (optionally)	Set of 6 pieces mounting brackets, model ATD1
Installation	See drawing
Standards	CE-conformity, RoHS

Models	Reset	Capillary length m
TD1	automatic	1,8
TD2	automatic	3,0
TD3	automatic	6,0
TDR1	manual	1,8
TDR2	manual	3,0
TDR3	manual	6,0
Accessories:	ATD1 Set of 6 pieces mounting brackets	



Electrical wirings

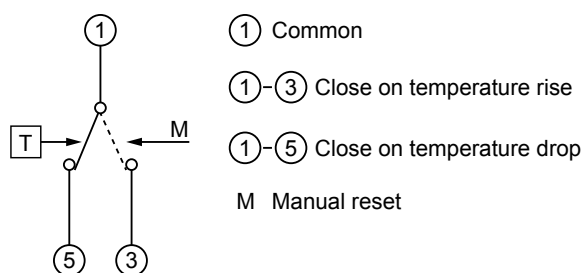

Function

The frost protection thermostat switches when the temperature sensed by capillary for a minimum length of 30 cm drops below the temperature set on the knob. When temperature increases, the contact returns automatically to the initial position. For TDR versions it is necessary a manual reset from user to allow the contact to return to the initial position.

The gas inside the sensible element increases his volume and with a mechanism acts on the microswitch. The capillary is sensible to temperature for the whole length.

Installation

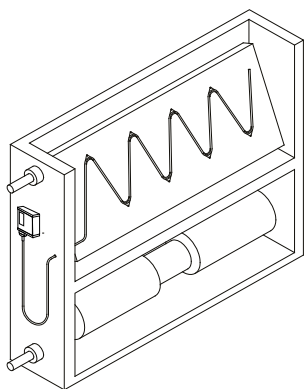

The thermostat is available with 3 different sensible elements that allow the use in different applications.

The version with 1,8 m capillary length has a bulb that allows the use of a pocket.

The versions with 3 and 6 m can be used in air ducts or battery exchanger.

The capillary must be applied uniformly on the surface to be controlled, see drawing besides.

This surface must not be folded with a radius of curvature lower than 20 mm and there must not be any bottlenecks. Therefore the use with mounting bracket model ATD1 is recommended.

In addition avoid to put the capillary across iron plate wall without any protection.

The room temperature around the unit must never be below the setpoint temperature.

Dimensions (mm)

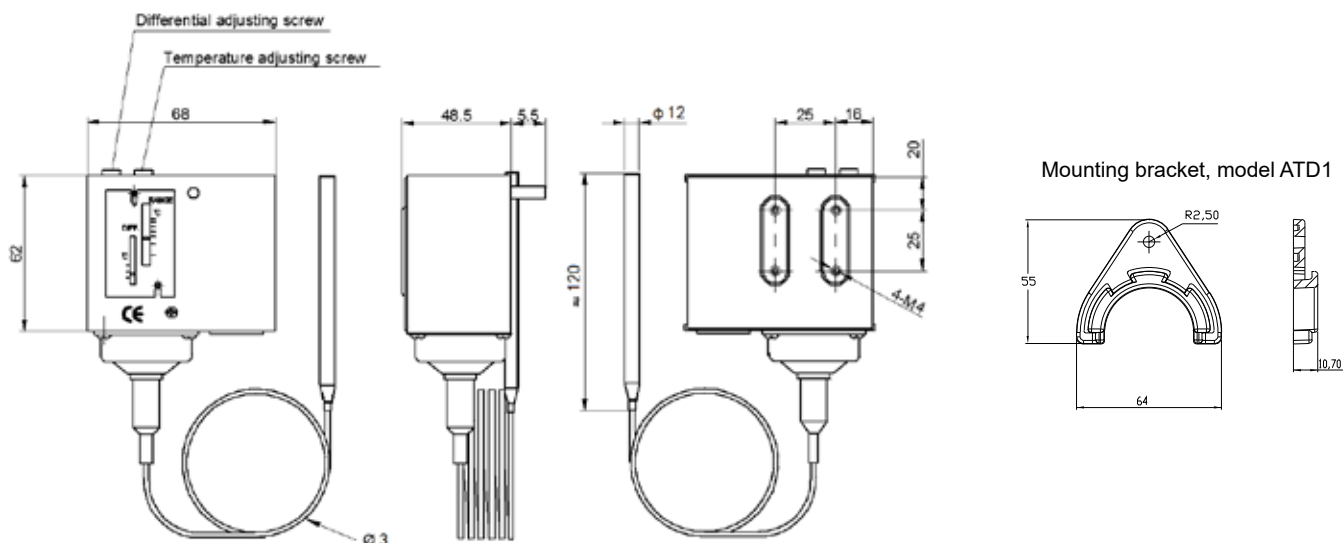

■ Description



The room thermostat TAM, designed simply and elegant, combines simplicity of operation and use with ease of installation.

■ Technical specifications

Measurement range	10...+30°C
Differential	<0,7° K
Electrical rating	10 (2) A, 250 V AC
Min. current	200 mA
Max. temperature	0...+50°C
Protection	IP30
Dimensions	84 x 84 x 36 mm
Standards	CE-conformity



Models	Power supply	Features
TAM31	230 Vac / 24 Vac	Basic version, changeover contact
TAM32	230 Vac	with LED for closed contact
TAM33	230 Vac	with LED for closed contact and on/off switch
TAM34	230 Vac	with LED for closed contact and summer/winter switch
TAM42	24 Vac	with LED for closed contact
TAM43	24 Vac	with LED for closed contact and on/off switch
TAM44	24 Vac	with LED for closed contact and summer/winter switch



Electrical wirings

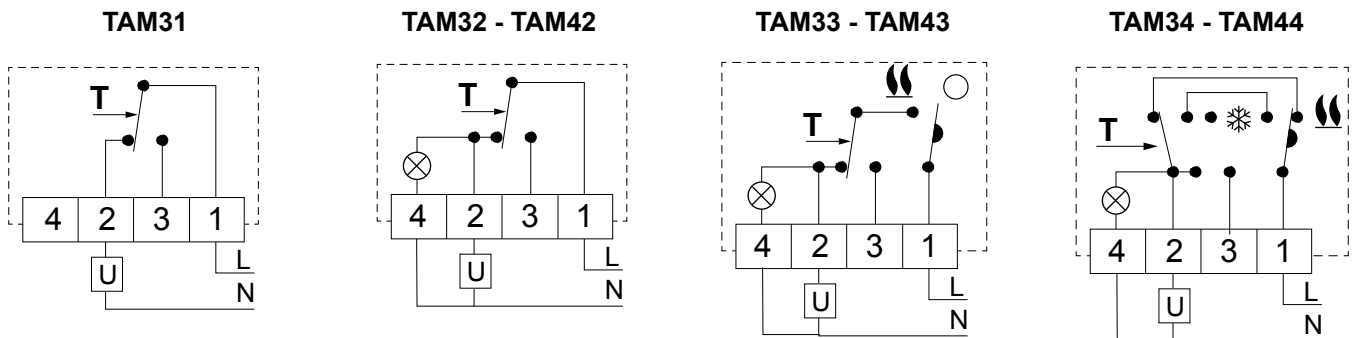

Installation

WARNING! The installation described below must be carried out by qualified personnel observing the safety rules and regulations in force.

Verify that the data plate (power supply, contact, etc.) are suitable to the installation conditions. Make sure that the thermostat is not affected by drafts, direct sunlight or other heat sources (Fig. 1). Install the thermostat on a flat surface. If the device is mounted on a metal surface to ensure that the same are properly grounded.

1. Loosen the screw on the lid, then remove the cover and knob.

DO NOT EVER TURN THE SHAFT OF THE KNOB: THE THERMOSTAT CAN LOOSE THE SETTING.

2. Secure the device to the wall using screws

3. Make the electrical connections using the appropriate terminals according to the corresponding electrical wiring above.

4. Replace the knob and the cover by tightening the screw.

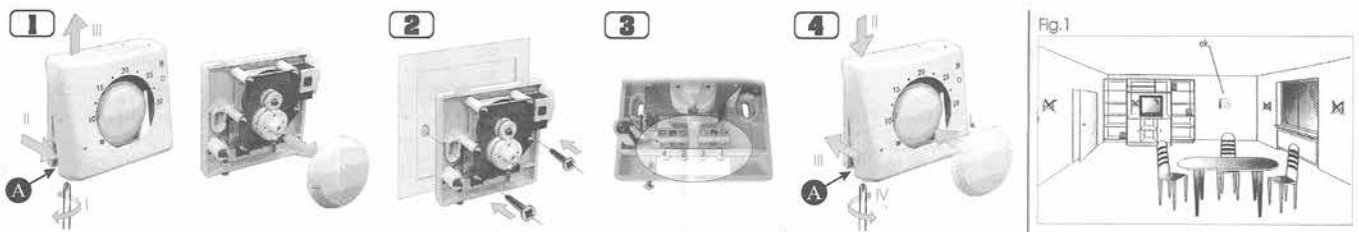

Dimensions (mm)

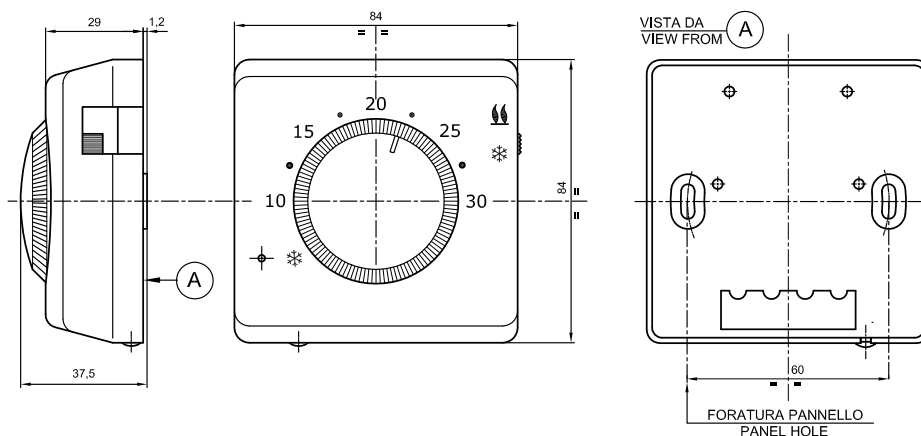



Description

The industrial room thermostat TA is suitable for temperature control in industrial rooms such as greenhouses, industrial buildings, warehouses etc.

Technical specifications

Measurement range	see schedule
Tolerance	$\pm 3^{\circ}\text{C}$
Differential	$2 \pm 1^{\circ}\text{C}$
Electrical rating	16 (4) A, 250 V AC
Max. temperature	$+70^{\circ}\text{C}$
Protection	IP55
Isolation class	I
Overvoltage category	II
Nominal impulse voltage	4 kV
Bulb	Spiral capillary in stainless steel
Dimensions	97 x 120 x 56 mm
Standards	CE-conformity



Models	Range °C	External knob	Internal knob
TA1	-15...+40	•	
TA2	0...+60	•	
TA2S	0...+60		•
TA3	0...+40	•	
TA3S	0...+40		•

Electrical wirings

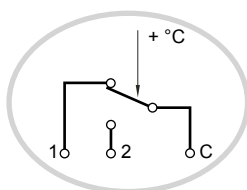

Dimensions (mm)

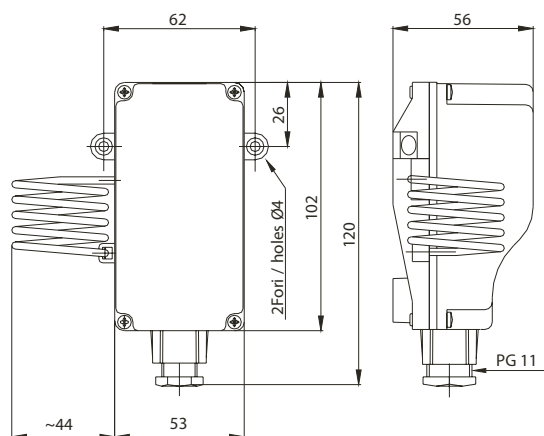

Description

The electromechanical capillary thermostat TK, three available ranges, is suitable for most of temperature control requirements for heating and cooling applications. The thermostats are available with external, internal range knob and with fix temperature calibration.

Technical specifications

Measurement range	see schedule
Differential	see schedule
Tolerance	Min. temp. $\pm 5^{\circ}\text{C}$, min. temp. $\pm 3^{\circ}\text{C}$
Electrical rating	16 (4) A, 250 V AC - 6 (1) A, 400 V AC
Max. housing temperature	T 85
Max. bulb temperature	T 120
Temperature gradient	1 $^{\circ}\text{C}/\text{min}$
Isolation class	I
Overvoltage category	II
Nominal impulse voltage	4 kV
Dimensions	84 x 84 x 36 mm
Standards	CE-conformity



Models	Range $^{\circ}\text{C}$	Protection (*)	Differential	Internal knob	External knob	Reset	Capillary length mm
TK1	0...+60	IP43	$3\pm 1^{\circ}\text{C}$		•		1000
TK1S	0...+60	IP55	$3\pm 1^{\circ}\text{C}$	•			1000
TK2	0...+90	IP43	$4\pm 2^{\circ}\text{C}$		•		1000
TK2S	0...+90	IP55	$4\pm 2^{\circ}\text{C}$	•			1000
TK3	-35...+35	IP43	$2\pm 1^{\circ}\text{C}$		•		1500
TKL100	fissa 100 $^{\circ}\text{C}$	IP55				manual	1000
TKL1	+90...+110	IP55		•		manual	1000

(*)The degree of protection is ensured by placing the unit horizontally or vertically with the cable entry facing down.

Electrical wirings

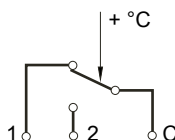

Dimensions (mm)

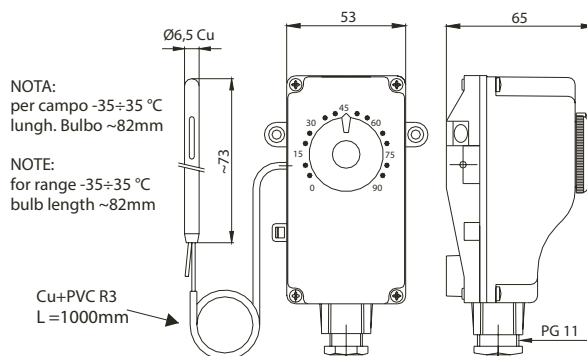

Description

The electromechanical immersion thermostat TI, three available ranges, is suitable for most of temperature control requirements for heating and cooling applications. The thermostats are available with external, internal range knob and with fix temperature calibration.

Technical specifications

Measurement range	see schedule
Differential	6±2°C
Tolerance	Min. temp. ±6°C, max. temp. ±4°C
Temperature gradient	1 °C/min
Electrical rating	16 (4) A, 250 V AC - 6 (1) A, 400 V AC
Max. housing temperature	T 85
Max. bulb temperature	T 120
Protection	IP43 (*)
Isolation class	I
Overvoltage category	II
Nominal impulse voltage	4 kV
Dimensions	84 x 84 x 36 mm
Standards	CE-conformity, PED group 2



(*)The degree of protection is ensured by placing the unit horizontally or vertically with the cable entry facing down.

Models	Range °C	Internal knob	External knob	Reset
T11	0...+60		•	
T11S	0...+60	•		
T12	0...+90		•	
T12S	0...+90	•		
T13	+30...+70		•	
TIL100	Fix 100°C			manual
TIL1	+90...+100	•		manual

Electrical wirings

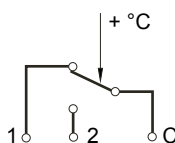

Dimensions (mm)

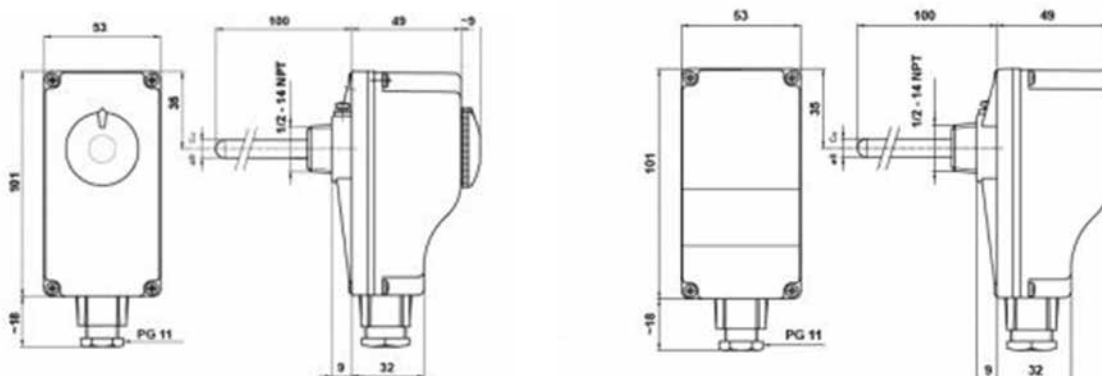

Description



The electromechanical strap-on pipe thermostat TC with liquid expansion sensor, two available ranges, is suitable for most of temperature control requirements for heating and cooling applications. The thermostats are available with external, internal range knob and as safety limiter. The thermostat comes with a spring band and a 20 g bag of thermal paste.

Technical specifications

Measurement range	see schedule
Tolerance	see schedule
Differential	see schedule
Electrical rating	16 (4) A, 250 V AC - 6 (1) A, 400 V AC
Max. temperature	T 85
Protection	IP40
Isolation class	I
Overvoltage category	II
Nominal impulse voltage	4 kV
Dimensions	105 x 42 x 38 mm
Accessory	Spring band and thermal paste (included)
Standards	CE-conformity



Models	Range °C	Differential	Tolerance	External knob	Internal knob	Reset
TC1	+5...+60	6±2°C	±5°C	•		
TC1S	+5...+60	6±2°C	±5°C		•	
TC2	+10...+90	6±2°C	±5°C	•		
TC2S	+10...+90	6±2°C	±5°C		•	
TCL65	Fix 65		+0 -6°C			manual
TCL1	+30...+70		+0 -6°C		•	manual

Electrical wirings

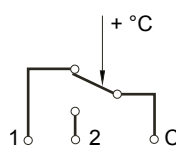

Dimensions (mm)

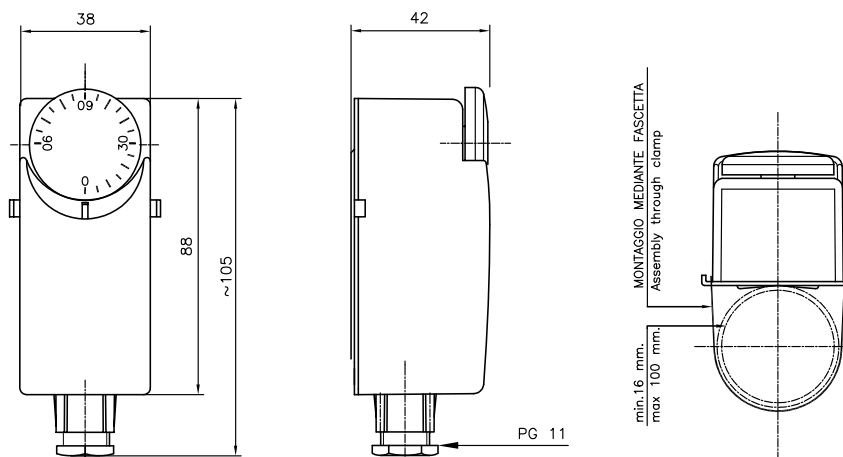



Description

The RTA02 controller is designed to control fan coil in heating and cooling systems. RTA02 controls heating and/or cooling valves, fan speeds with 2 or 4-pipe fan coil.

Technical specifications

- 2 and 4 pipes selectable fan coil applications
- Fan control with manual 3-speeds setting
- ON-OFF control action for actuators
- Analog input for water temperature sensor
- Output voltage for valves 230 V AC, fan motor 230 V AC
- Power supply: 230 Vac, 50/60 Hz
- Frost protection function
- Display with blue backlight
- CE certification



Technical features

Control range	5...35 °C		
Power supply	230 V AC, 50/60 Hz		
Outputs	On-Off (valves)		
	3 speed output, 230 V AC. max 2 A resistive, 1 A inductive		
Knob and selectors	Fan	OFF - LOW - MED - HIGH	Power on, fan speed
	Set point	Push bottom ▲ ▼	Set point setting
	Operating mode	Push bottom M	Heat, cool, auto or fan
Analogue Inputs	Water temperature	Strap-on	
Accuracy	±1 K		
Application	2- or 4-pipe-fan coil		
Housing	Single housing 86 x 86 x 23,5 mm		
Protection class	IP30		
Working temperature	0...45° C		
Storage temperature	-10...+50° C		
Working humidity	5...95% RH non condensing		



Electrical wiring

2-pipe system

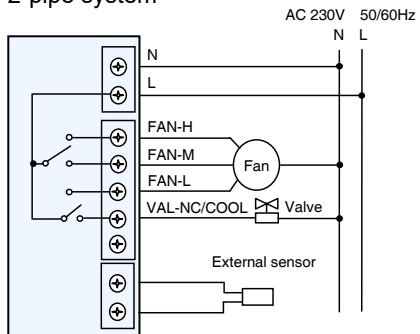

4-pipe system

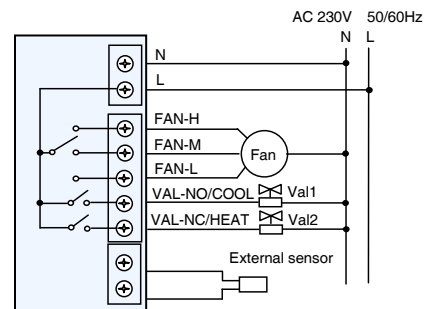

Mounting

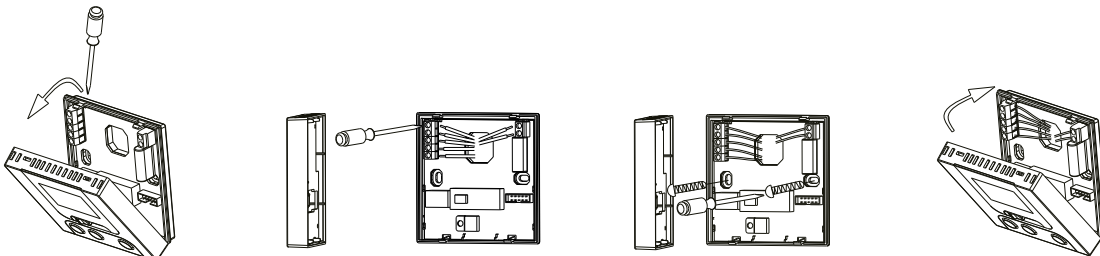



Description

The RTA34 thermostat, in its various versions, is suitable for application in heating, air conditioning and refrigeration systems.

The RTA34 can be configured with the following temperature ranges:

- +5...+35°C
- 10...+20°C
- 35...+5°C
- +35...+65°C

The choice of temperature range must be made at startup by acting on the dip switches.

Then place the label, with the chosen temperature scale, on the front of the housing.



Technical specifications

Power supply	24 VAC/DC, 50/60 Hz, ±10%
Relay output with switch contact	max 16 (6) A, 230 VAC
Adjusting action	ON-OFF
Adjustable differential	1-8 K
Control output	ON-OFF
Temperature probe connection	NTC10K
Screw clamps for cables with maximum cross-sectional area	2,5 mm ²
Working temperature °C	0...50°C
Working range RH	<80% RH
Storage temperature	-20...+70°C <80% RH
Protection type	IP40
Rail mounting	DIN
Standards	CE conformity, RoHS

Functioning

The RTA34 thermostat provides temperature control with ON-OFF action with a differential set by dip switches.

Cooling action

The RTA34 thermostat is equipped with a relay with a switching contact. The relay is energized when the temperature detected by the NTC probe exceeds the temperature value set on the knob plus the value of the differential. The contact between terminals C-NO is closed. When the temperature drops to the set value (set point), the relay de-energizes, opens the contact between the C-NO terminals, and closes the contact between the C-NC terminals.

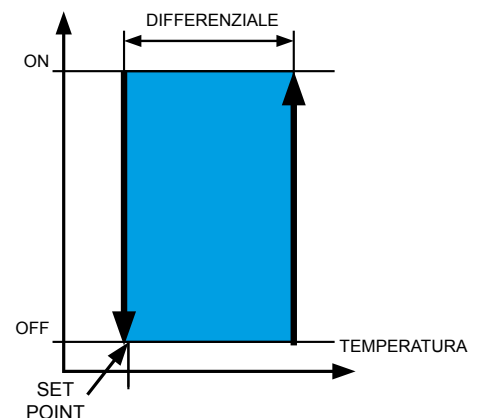



Heating action

For operation with heating action, dip switch 6 must be set to OFF.

The relay is energized when the temperature detected by the NTC probe falls below the temperature value set on the knob minus the value of the differential.

The contact between terminals C-NO is closed.

When the temperature drops to the set value (set point), the relay de-energizes, opens the contact between the C-NO terminals and closes the contact between the C-NC terminals.

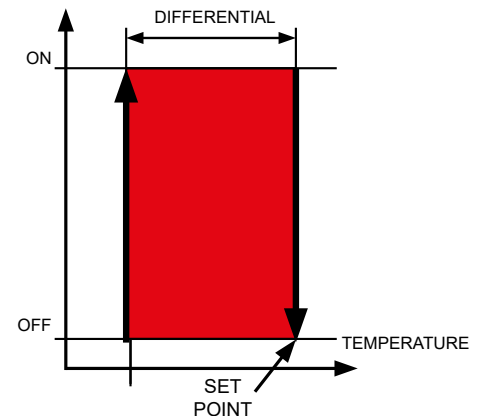

Electrical wirings

The above connections refer to cooling operation. For heating operation, dip switch 6 must be set to OFF.

In the factory configuration, the dip switches are set to OFF.

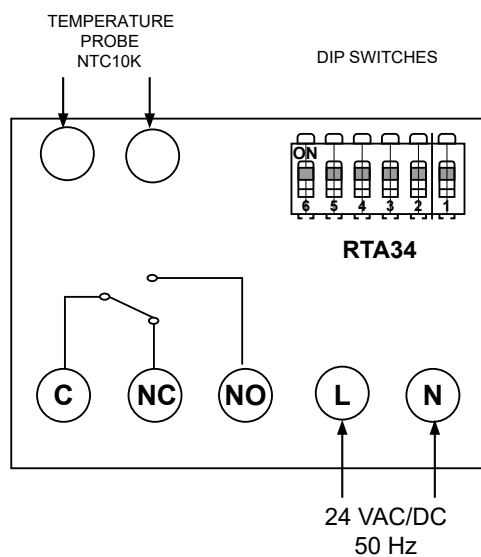

Setting DIP switches

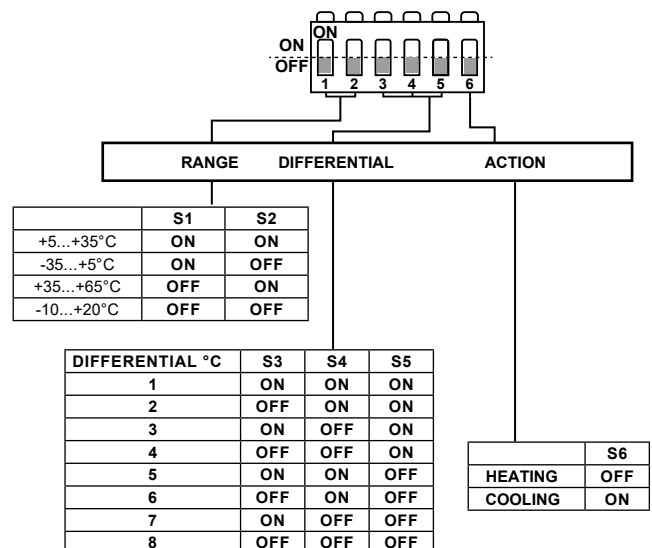

Dimensions (mm)

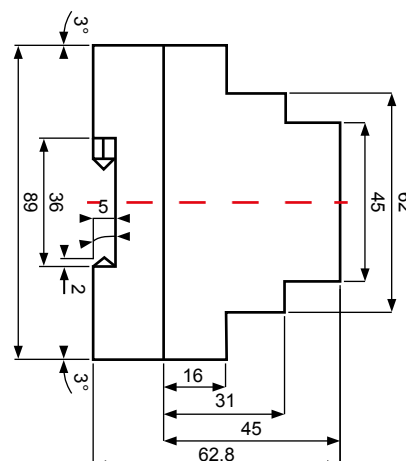
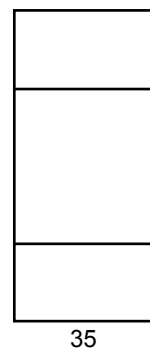



Description

The RTA37 thermostat, in its various versions, is suitable for application in heating, air conditioning and refrigeration systems.

The RTA37 can be configured with the following temperature ranges:

- +5...+35°C
- 10...+20°C
- 35...+5°C
- +35...+65°C

The choice of temperature range must be made at startup by acting on the dip switches.

Then place the label, with the chosen temperature scale, on the front of the housing.



Technical specifications

Power supply	230 VAC, 50/60 Hz
Relay output with switch contact	max 3 A, 230 VAC
Adjusting action	ON-OFF
Adjustable differential	1-8 K
Control output	ON-OFF
Temperature probe connection	NTC10K
Screw clamps for cables with maximum cross-sectional area	2,5 mm ²
Working temperature °C	0...50°C
Working range RH	<80% RH
Storage temperature	-20...+70°C <80% RH
Protection type	IP40
Rail mounting	DIN
Standards	CE conformity, RoHS

Functioning

The RTA37 thermostat provides temperature control with ON-OFF action with a differential set by dip switches.

Cooling action

The RTA37 thermostat is equipped with a relay with a switching contact. The relay is energized when the temperature detected by the NTC probe exceeds the temperature value set on the knob plus the value of the differential. The contact between terminals C-NO is closed. When the temperature drops to the set value (set point), the relay de-energizes, opens the contact between the C-NO terminals, and closes the contact between the C-NC terminals.

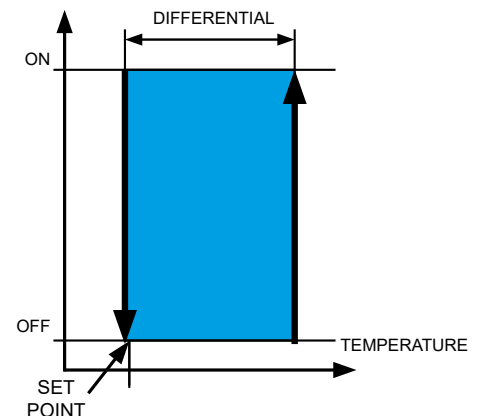



Heating action

For operation with heating action, dip switch 6 must be set to OFF.

The relay is energized when the temperature detected by the NTC probe falls below the temperature value set on the knob minus the value of the differential.

The contact between terminals C-NO is closed.

When the temperature drops to the set value (set point), the relay de-energizes, opens the contact between the C-NO terminals and closes the contact between the C-NC terminals.

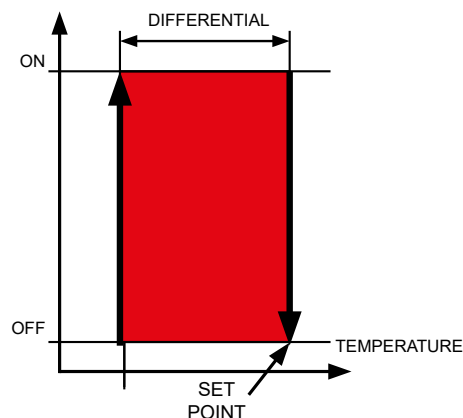

Electrical wirings

The above connections refer to cooling operation. For heating operation, dip switch 6 must be set to OFF.

In the factory configuration, the dip switches are set to OFF.

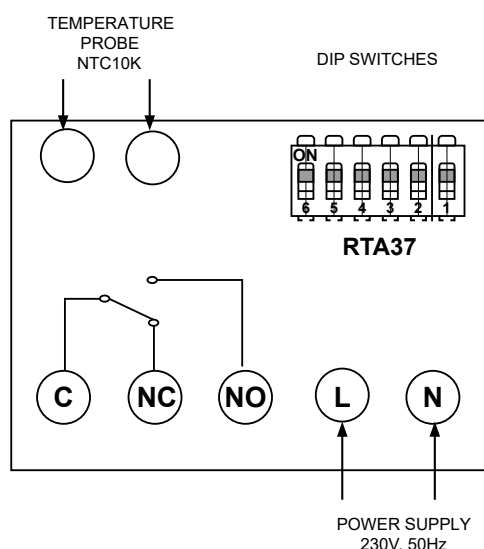

Setting DIP switches

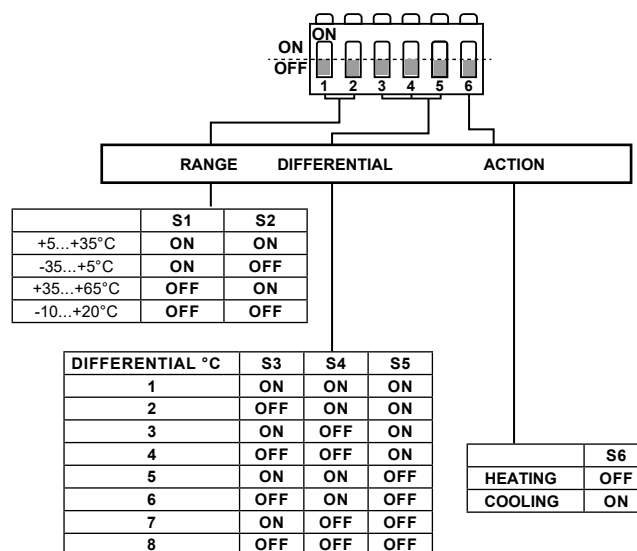

Dimensions (mm)

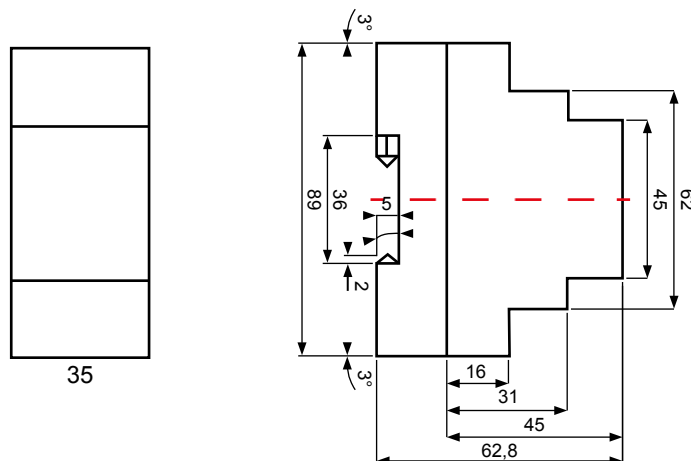



violetline

flow switches



Description

The flow switch serie FS is designed for controlling flow rates in pipes and ducts employed in HVAC applications from 1" up to 8", optionally up to 10". In particular for monitoring flow in water, for pumps in oil circulation, cooling and lubrication systems, heat exchangers, compressors and is used as flow control device or as water failure protection switch. Models available with brass and stainless steel body for aggressive media.

Technical specifications

- Flow rate** See schedule
- Switching output** Dustproof microswitch as potential-free SPDT contact
- Electrical rating** 16 (8) A, 24 - 250 VAC, at 24 VAC min. 150 mA
- Lifetime** 100.000 cycles at nominal load
- Electrical connection** Screw terminal, wire up to 1,5 mm², cable Ø 6...9 mm
- Max. pressure** See schedule



Calibration The flowswitch is factory calibrated at its min. sensitivity in horizontal position. To increase the set value turn clockwise the adjustment screw (see drawing 1). The cut-out value must be ≥ the minimum flow necessary to guarantee the protection of the plant. The units without "T" fittings are supplied with 4 paddles, which must be cut off according to the pipe. All devices can be supplied with "T" connection on request as schedule indications.

- Housing** ABS, RAL 9010, UV resistant
- Cable conduit** M20 x 1,5 mm
- Body and lever material** 1" GAS, brass or stainless steel Aisi 316, optionally with 1" NPT thread
- Paddles material** Stainless steel Aisi 316

- Dimensions** See drawing
- Weight** 600 gr
- Protection type** IP65
- Protection class** III
- Max. fluid temperature** -25 ...+120°C
- Working humidity RH** 10...95% RH, non-condensing
- Working temperature °C** -40 ...+85°C
- Storage temperature** -20 ...+60°C

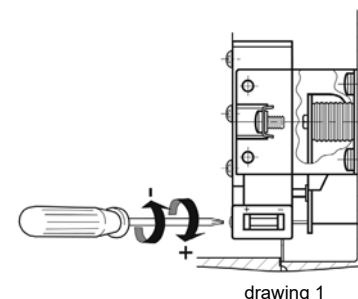

Installation Horizontal and vertical, screw-in thread, Rp 1" (ISO7/1) shall be installed far from elbows or throttlings, with arrow on flow direction. If pipe is vertical, recalibrate range to balance paddle weight on the adjusting screw for the switch-on/off values clockwise. If the device is downwards mounted take care to slugs, and apply it in a straight pipe far from filters, valves, etc with length at least 5 times the diameter of pipe upstream and downstream the unit. The paddles must be installed starting from the shortest.

Standards CE conformity, RoHS

Models	Fluid	Max. pressure	Body material
FS1	normal	15 bar	brass
FS2	aggressive	30 bar	stainless steel Aisi 316

Option suffix **NPT** for body with 1" NPT thread
suffix **-10** with 8" paddle for 10" pipe size

Electrical wirings

Red – Blue: flow velocity \geq switch-on value
 Red – Yellow: No flow or flow velocity has fallen below the adjusted switch-off value

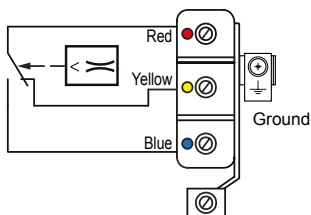

Installation

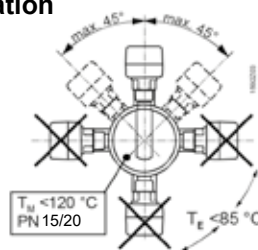

Flow rates in m³/h

Line pipe size	Paddle size	Flow m ³ /h				Max. recommended flow m ³ /h
		Flow increase Min. flow rate R to B closes	Flow increase Max. flow rate R to B closes	Flow decrease Min. flow rate R to Y closes	Flow decrease Max. flow rate R to Y closes	
1"	1	0,8	2,2	1,2	2,3	3,6
1" 1/4	1	0,93	2,52	1,5	2,8	6,1
1" 1/2	1, 2	1,1	3,9	2,37	4,3	9,2
2"	1, 2	2,0	6,05	3,8	6,5	15
2" 1/2	1, 2, 3	3,0	7,3	4,4	8,4	24
3"	1, 2, 3	5,0	11,7	6,2	12,6	36
4"	1, 2, 3	10,0	30,0	8,06	36,0	60
5"	1, 2, 3	21,1	51,4	24,0	69,0	94
6"	1, 2, 3, 4	12,4	29,0	20,0	33,7	120
	1, 2, 3	24,0	72,0	32,7	90,0	120
8"	1, 2, 3, 4	23,9	83,4	34,6	96,0	240
	1, 2, 3	48,4	174	66,8	200	240
10" *	1, 2, 3, 5	51	180	69	198	360

The values of minimum and maximum flow rate can be changed during installation shortening the paddles. The values in the table were measured by mounting the flow switch with the body horizontally. * Flow rates for this size are calculated.

Dimensions (mm)

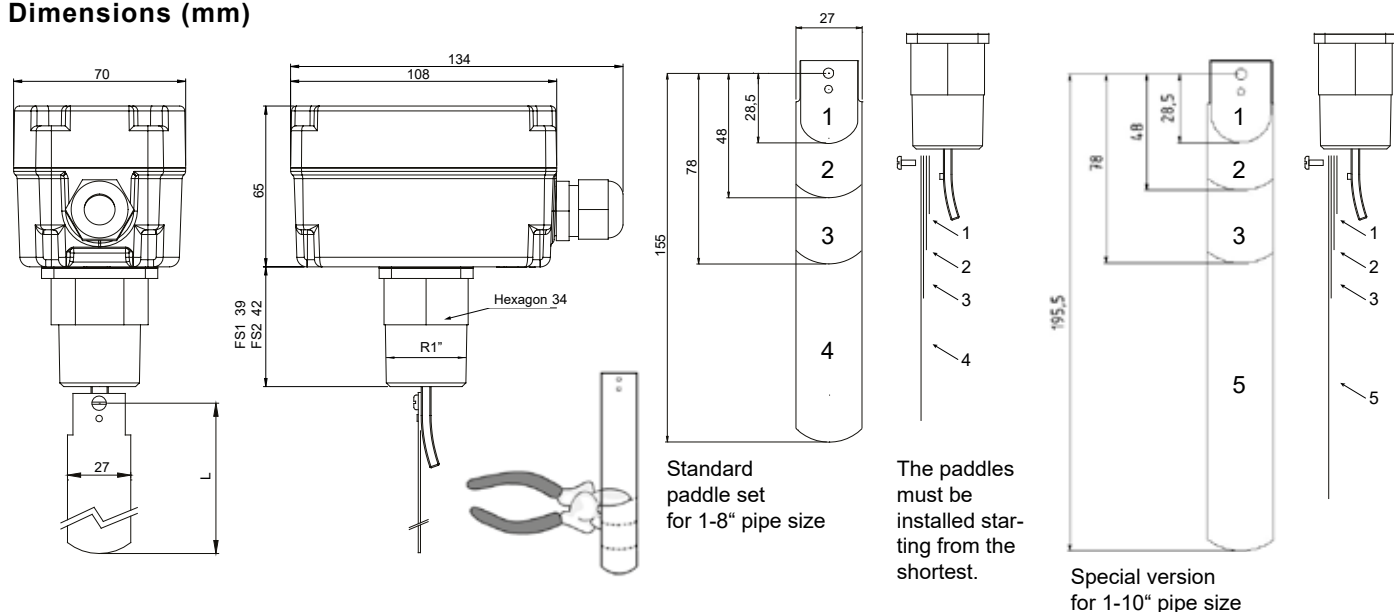

ATTENTION

If flowswitch is used as a minimum flow controller, it is necessary to add another device downstream for alarm condition activation.



Description

The flow switch serie FL is designed for controlling flow rates in pipes and ducts employed in HVAC applications from 3/8" up to 2". In particular for monitoring flow of liquid media, pumps in oil circulation, cooling and lubrication systems, heat exchangers, compressors and is used as flow control device or as water failure protection switch.

Technical specifications

Flow rate	See schedule
Switching output	Dustproof microswitch SPDT contact
Electrical rating	3 A, 250 V AC; 5 A, 125 V AC
Lifetime	100.000 cycles at nominal load
Electrical connection	DIN 43650A connector
Max. pressure	25 bar
Average pressure loss	0.01 bar at Q max
Hysteresis	min. 0,7 l/min.
Housing	ABS, black
Connection	Female thread T-fitting
Body and lever material	Nickel plated brass
Paddles material	Stainless steel Aisi 316L
Dimensions	See drawing
Weight	See schedule
Protection type	IP65
Protection class	I
Max. pipe temperature	-20 ...+110°C
Working humidity	10...95% RH, non-condensing
Working temperature	-40 ...+90°C
Storage temperature	-40 ...+90°C
Installation	Horizontal or vertical, shall be installed far from elbows or throttlings, with arrow on flow direction. If pipe is vertical, recalibrate range to balance paddle weight. If the device is downwards mounted take care to slags, and apply it in a straight pipe far from filters, valves, etc with length at least 5 times the diameter of pipe upstream and downstream the unit.
Standards	CE conformity, RoHS



Models	Connection	Flow rate l/min H ₂ O	Max. recommended flow rate l/min H ₂ O
FL10	G 3/8	4.4 (3.7) - 5.9 (5.1)	10
FL15	G 1/2	4.4 (3.7) - 5.9 (5.1)	20
FL20	G 3/4	9.4 (8.0) - 12.8 (10.8)	40
FL25	G 1	14.7 (12.5) - 19.9 (16.9)	60
FL32	G 1 1/4	24.1 (20.5) - 32.7(27.8)	80
FL40	G 1 1/2	37.7 (32.1) - 51.0 (43.4)	100
FL50	G 2	59.0 (50.1) - 79.8 (67.8)	150

Note: The flow rate values indicate operating point. The values between the brackets indicate reset point and were measured by mounting the flow switch with the body horizontally.



Electrical wirings

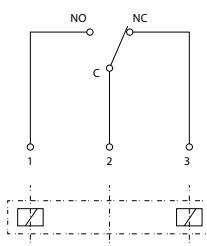

Installation

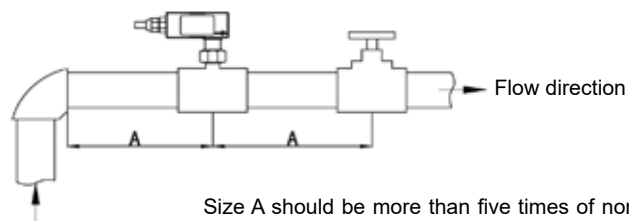
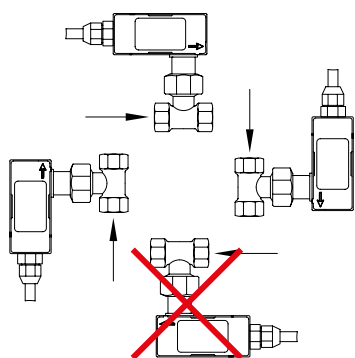

Size A should be more than five times of nominal size

Flow direction

Attention: the flow direction should be the same as the arrow direction, do not pull the black plastic shell.

Dimensions (mm)

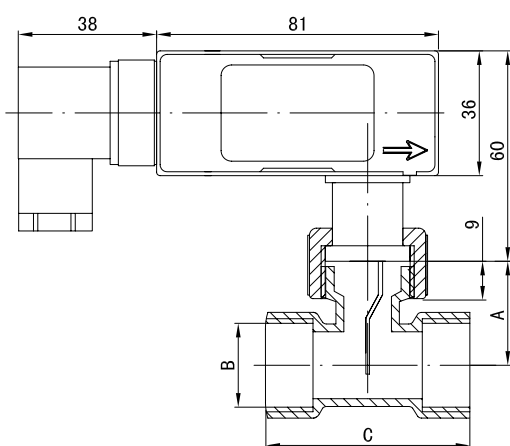

A mm	B mm	C mm	Weight kg
28	G 3/8	58	0,33
28	G 1/2	58	0,30
28	G 3/4	58	0,32
34	G 1	58	0,40
34	G 1 1/4	72	0,47
34	G 1 1/2	72	0,57
46	G 2	72	0,72



Description

The flow switch serie FL200 is designed for controlling flow rates in pipes and ducts employed in HVAC applications from DN32 up to DN200. In particular for monitoring flow in water, for pumps in oil circulation, cooling and lubrication systems, heat exchangers, compressors and is used as flow control device or as water failure protection switch. Models available with brass and stainless steel body for aggressive media.

Technical specifications

Flow rate	See schedule
Switching output	Dustproof microswitch as potential-free SPDT contact
Electrical rating	See schedule
Lifetime	100.000 cycles at nominal load
Electrical connection	DIN 43650A connector
Max. pressure	25 bar
Average pressure loss	0.01 bar at Q max
Hysteresis	min. 0.7 l/min.
Housing	ABS, black
Connection	Male thread fitting 1/2" ISO
Body and lever material	Nickel plated brass
Paddles material	Beryllium copper alloy
Dimensions	See drawing
Protection type	IP65
Protection class	II
Max. pipe temperature	-25 ...+110°C
Working humidity	10...95% RH, non-condensing
Working temperature	-25 ...+80°C
Storage temperature	-40 ...+80°C
Installation	Horizontal or vertical, shall be installed far from elbows or throttlings, with arrow on flow direction. If pipe is vertical, recalibrate range to balance paddle weight. If the device is downwards mounted take care to slags, and apply it in a straight pipe far from filters, valves, etc with length at least 5 times the diameter of pipe upstream and downstream the unit.
Standards	CE conformity, RoHS



Models	Electrical rating
FL200A	0,1 A, 125 V AC; min. 1 mA, 5 V DC
FL200B	3 A, 250 V AC; 5 A, 125 V AC; min. 160mA, 5 V DC

Note: The values in the table were measured by mounting the flow switch with the body horizontally.

Electrical wirings

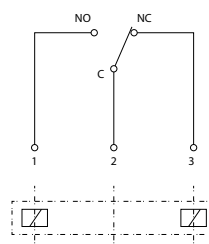



Pipe DN	Flow m ³ /h				Max. recommended flow m ³ /h
	Paddle 1	Paddles 1, 2	Paddles 1, 2, 3	Paddles 1, 2, 3, 4	
32	1,7 (1,4)...1,8 (1,5)	-	-	-	6
40	1,7 (2,4)...1,8 (2,0)	-	-	-	9
50	4,5 (3,8)...4,9 (4,2)	1,2 (1,0)...1,4 (1,2)	-	-	15
65	9,5 (8,1)...11,2 (9,5)	3,2 (2,7)...3,6 (3,1)	-	-	24
80	13,5 (11,5)...14,8 (12,6)	5,9 (5,0)...7,4 (6,3)	1,4 (1,2)...2,7 (2,3)	-	36
100	25,8 (21,9)...30,2 (25,7)	8,3 (7,1)...8,8 (7,5)	3,3 (2,8)...3,9 (3,3)	2,3 (2,0)...3,8 (3,2)	60
125	35,5 (30,2)...41,6 (35,4)	11,7 (9,9)...13,1 (11,1)	5,1 (4,3)...5,8 (4,9)	3,1 (2,6)...3,8 (3,2)	85
150	49,6 (42,2)...54,7 (46,5)	14,8 (12,6)...16,9 (14,4)	6,2 (5,3)...6,6 (5,6)	4,0 (3,4)...4,5 (3,8)	110
200	88,2 (75,0)...97,3 (82,7)	26,3 (22,4)...30,0 (25,5)	11,0 (9,4)...11,7 (9,9)	7,1 (6,0)...8,0 (6,8)	203

Values with increasing flow, in brackets values with decreasing flow.

FL200A / FL200B – Setpoint Adjustment

- Access via the cover opposite the connector.
- Open with a flathead screwdriver, avoiding excessive force.
- Adjust using the visible cross-head screw; direction for increase/decrease indicated.
- Make only small adjustments to prevent damage.
- Close the cover securely after adjustment.

Installation

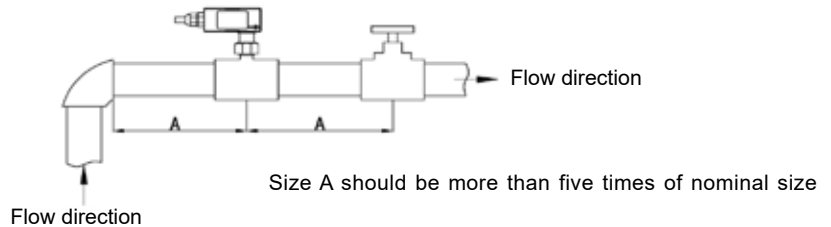
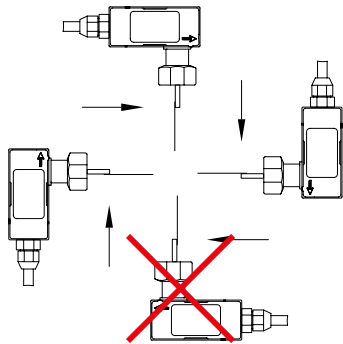

Attention: the flow direction should be the same as the arrow direction, do not pull the black plastic shell.

Dimensioni (mm)

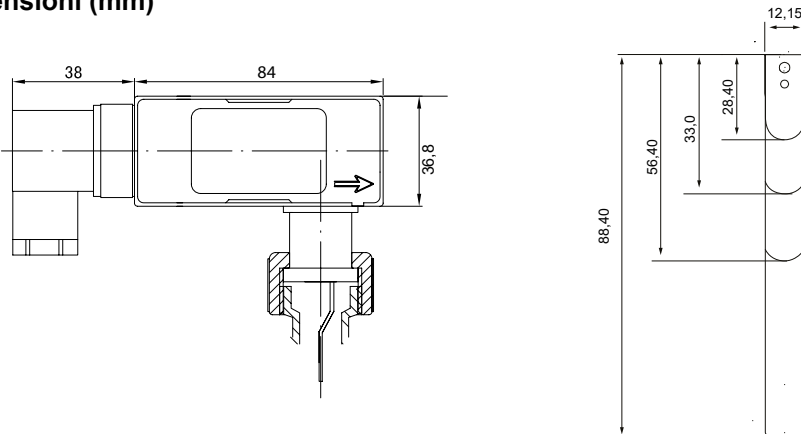



Description

The flow switch serie FLUS001 is designed for controlling flow rates in pipes and ducts employed in HVAC applications from 3/4" up to 8". The reed contact guarantees a complete isolation between the electrical and the mechanical part.

Technical specifications

Flow rate	See schedule
Switching output	Reed SPST, max. 26 VA, 20 W
Electrial rating	1 A, 230 VAC, 48 VDC
Electical connection	1,5 m cable 2x0,5 mm ² , 300/500V UV and weather resistant
Max pressure	10 bar
Average pressure loss	0.01 bar at Q max
Hysteresis	min. 0.7 l/min.
Housing	PPO, black
Connection	Threaded female 3/4 ring brass nickeled
Body and lever material	Brass
Paddles material	Stainless steel
Dimensions	See drawing
Protection type	IP65
Protection class	I
Max. fluid temperature	-25 ...+100°C
Working temperature	-25 ...+70°C



Installation Horizontal or vertical, far from elbows or narrowing, with the arrow in the direction of flow. If the device is mounted downwards protect it from scale or impurities and apply it in a straight line away from the filters, valves, etc with a distance of at least 5 times the diameter of the pipe upstream and downstream of the unit.

Standards CE conformity, RoHS

Pipe	Length of paddle cut (mm)	Flow rate m ³ /h H ₂ O		Max. recommended flow rate m ³ /h H ₂ O
		Increasing flow ON	Decreasing flow OFF	
DN20	9	1,08	0,9	4
DN25	15	1,32	1,08	5
DN32	20	1,92	1,62	8
DN40	30	2,1	1,8	10
DN50	40	2,7	2,4	14
DN80	60	5,1	4,68	30
DN100	80 (do not cut)	6,36	5,82	40
DN150	80 (do not cut)	15,48	14,22	100
DN200	80 (do not cut)	30	28,98	180

Note: The values in the table were measured by mounting the flow switch with the body horizontally.



■ Electrical wirings



■ Installation

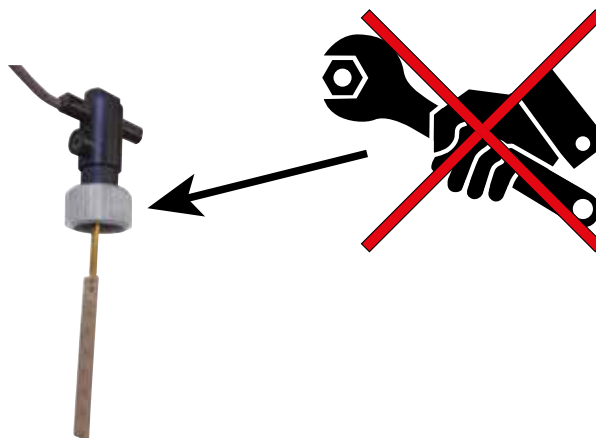
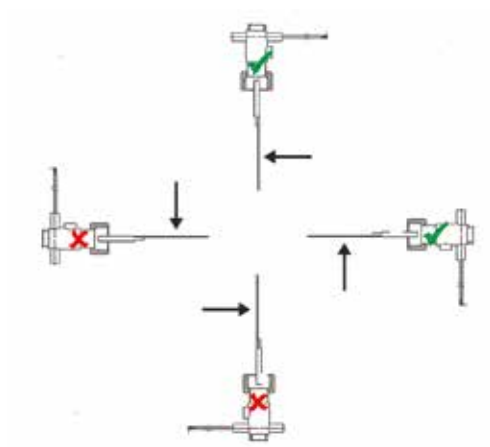

■ Dimensions (mm)

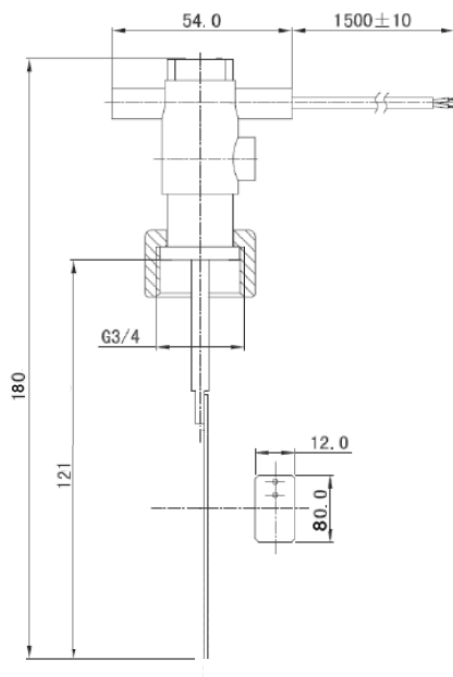



Description

The flow switch serie FLUS is designed for controlling flow rates in pipes and ducts employed in HVAC applications from 1" up to 2". The reed contact guarantees a complete isolation between the electrical and the mechanical part.

Technical specifications

Flow rate	See schedule
Switching output	Reed SPST, max. 26 VA, 20 W
Electrical rating	1 A, 230 VAC, 48 VDC
Electrical connection	RVV cable 2x0,5 mm ² , 300/500V UV and weather resistant
Max pressure	10 bar
Average pressure loss	0,01 bar at Q max
Hysteresis	min. 0,7 l/min.
Housing	PPE, black
Connection	Female threaded T-fitting (besides FLUS09AW), nut brass nickeled
Body and lever material	Brass
Paddles material	Brass
Sealing	NBR
Dimensions	See drawing
Protection type	IP65
Protection class	I
Max. fluid temperature	-25 ...+100°C
Working temperature	-25 ...+70°C
Installation	Horizontal or vertical, far from elbows or narrowing, with the arrow in the direction of flow. If the device is mounted downwards protect it from scale or impurities and apply it in a straight line away from the filters, valves, etc with a distance of at least 5 times the diameter of the pipe upstream and downstream of the unit.
Standards	CE conformity, RoHS



Models	Connection	Cable m	Setting m ³ /h	Flow rate m ³ /h H ₂ O		Max. recommended flow rate m ³ /h H ₂ O
				Increasing flow ON	Decreasing flow OFF	
FLUS002AW	G 3/4	2	0,3	0,5	0,3	4,8
FLUS006AW	G 1	2	0,4	0,6	0,4	7,8
FLUS007AW	G 1	1	0,95	0,78 - 0,99	0,74 - 0,95	7,8
FLUS011AW	G 1 1/4	4	1,92	2,4	1,62	10,8
FLUS010AW	G 1 1/2	1,5	1,6	1,62 - 2,01	1,53 - 1,95	18
FLUS009AW	-	4	2,76	2,49 - 3,21	2,44 - 3,17	21

Note: The values in the table were measured by mounting the flow switch with the body horizontally.



Electrical wirings

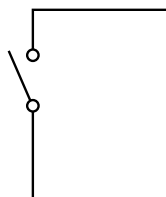

Installation

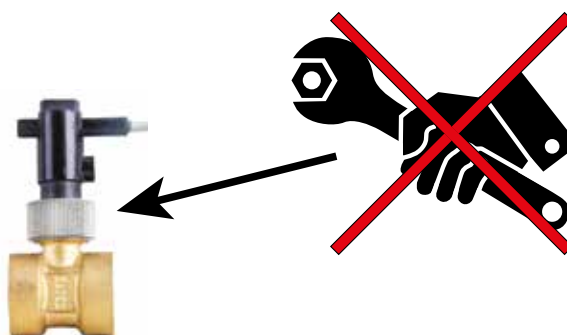
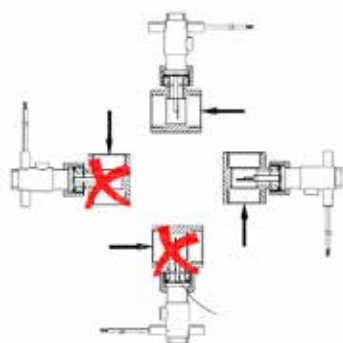

Dimensions (mm)

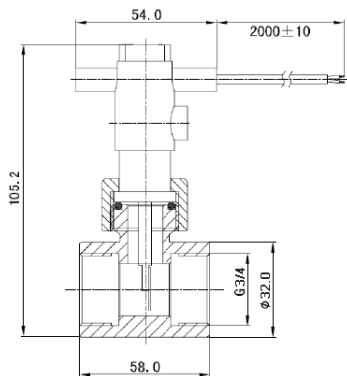

FLUS002AW

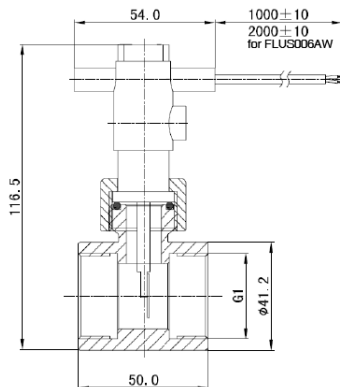

FLUS006AW / FLUS007AW

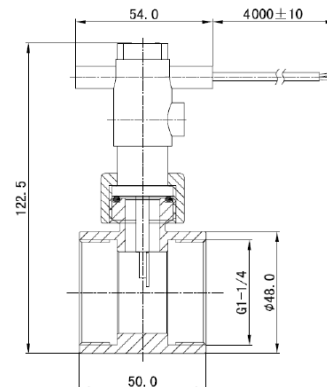

FLUS011AW

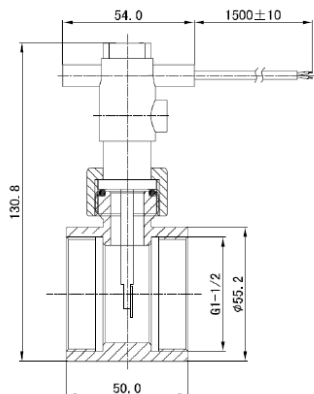

FLUS010AW

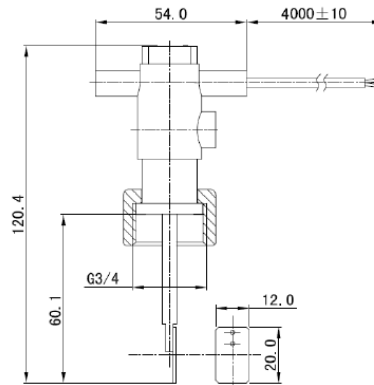

FLUS009AW

Level switch

FG



Description

The level switch serie FG is designed to control fluid level in tanks in an simple and effective way. The switching function through the reed contact (N/O or N/C contact) is determined by the installation position. The switching function can be reversed by simply rotating the level switch for 180°.

Technical specifications

Connector	Male thread G 1/2
Max. pressure	FG1, FG2 10 bar - FGP 4 bar
Contact	N/O or N/C depending on the installation
Electrical rating	Reed, max 240 V AC DC, max 40 W, max 0,5 A
Contact resistance	max 80 mOhm
Min. contact force	400 V DC / 1 sec.
Collegamenti elettrici	PVC braided cable AWG 24, 2 wires, 1 m length
Material	Polypropylene
Specific fluid weight	> 0,6 g/cm ³
Installation	Horizontal ±30°
Protection type	IP68
Standards	CE conformity, RoHS



Model	Fluid	Temperature	Body material	Connections
FG1	not aggressive	-10...+80° C	Polypropylene	single
FG2	not aggressive	-10...+80° C	Polypropylene	double
FGP	not aggressive	-10...+80° C	Polypropylene	single

Dimensions (mm)

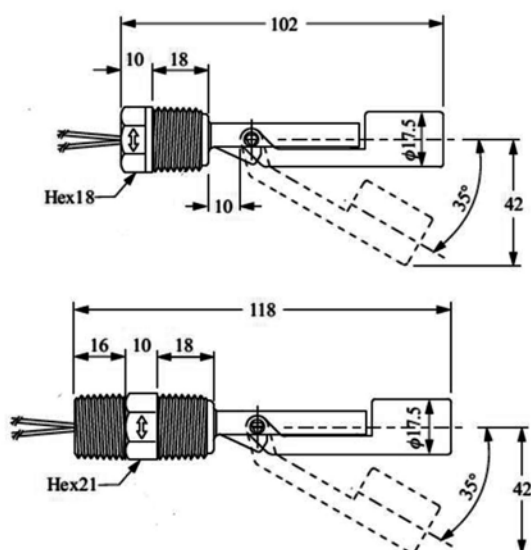

Description

The air flow switch serie FSA is designed for controlling flow rates od air and non aggressive gases in pipes and ducts employed in HVAC applications.



Technical specifications

Switching output	Dustproof microswitch as potential-free SPDT contact
Electrical rating	16 (8) A, 24 - 250 V AC, at 24 V AC min. 150 mA
Lifetime	100.000 cycles at nominal load
Electrical connection	Screw terminal, wire up to 1,5 mm ² , cable Ø 6...9 mm
Housing	ABS, white
Cable conduit	M20 x 1,5 mm
Lever material	Brass
Paddles material	Stainless steel Aisi 301
Dimensions	See drawing
Weight	600 gr
Protection type	IP65
Protection class	III
Max. fluid temperature	-10 ...+85°C
Working humidity RH	10...95% RH, non-condensing
Working temperature °C	-40 ...+85°C
Storage temperature	-40 ...+85°C
Standards	CE conformity, RoHS



Model	Min. cut-out value m/sec.	Min. cut-in value m/sec.	Max cut-out value m/sec.	Max cut-in value m/sec.
FSA1	1,0	2,5	8,0	9.2

Electrical wirings

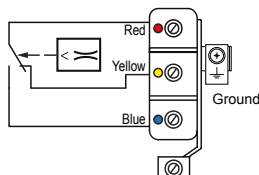

Dimensions (mm)

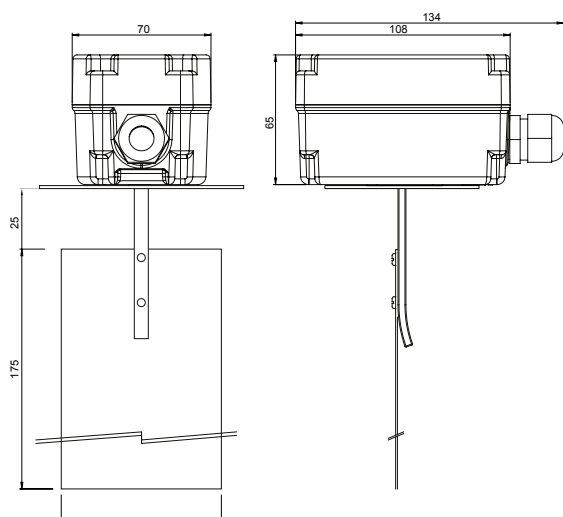

ATTENTION

The units are calibrated at the minimum switch-off value. A higher value can be adjusted by turning the range screw clockwise. Due to the risk of fracture at air speed higher than 5 m/s the paddle must be cut off on the marked side. When the paddle is cut off, the minimum cut-out value increases from 1 m/s to 2,5 m/s. Straights zones should be provided for a length of 5 x diameter upstream and downstream the location of installation to avoid air swirl and paddle instability.



blue**line**

pressure switches

Description

Air differential pressure switch serie PA for monitoring overpressure, vacuum and differential pressure of air or other non-combustible, non-aggressive gases. The switching pressure can be adjusted without a manometer at the adjustment knob with the guide value scale. Various versions are available for this with overlapping adjustment ranges of between 20 and 5000 Pa (0,2 and 50 mbar). Possible fields of application are monitoring air filters and ventilators, industrial cooling-air circuits, flows in ventilation ducts, overheating protection for fan heaters, controlling air and fire-protection flaps, frost protection for heat exchangers.

Technical specifications

Medium	Air, non-combustible and non-aggressive gases
Measurement range	20...300 Pa (0,2...3 mbar), 30...400 Pa (0,3...4 mbar), 50...500 Pa (0,5...5 mbar), 50...700 PA (0,5...7 mbar), 200...1000 Pa (2...10 mbar), 500...2500 Pa (5...25 mbar), 1000...5000 Pa (10...50 mbar), 100...1000 Pa (1...10 mbar)
Accuracy	±15%, min. ±10 Pa, drift <±15%
Mechanical working life	Over 10 ⁶ switching operations
Electrical rating	Max 1.5 (0.4) A / 250 VAC (low voltage version max. 0,1 A, 24 VDC on request)
Electrical connection	AMP flat plug 6.3 x 0.8 mm, acc. DIN 46244 or push-on screw terminals
Max. operating pressure	10 kPa (100 mbar) for all pressure ranges
Housing material	Switch body made of PA 6.6, cover made of PS
Cable conduit	M16x1,5 connection made of polyamide
Diaphragm material	Silicone, tempered at 200°C, free of gas emissions (NBR optionally)
Housing	approx. Ø 85 x 58 mm, weight 150 g
Protection type	IP54 (IP65 in version G)
Working humidity	0...95% RH, non-condensing
Working temperature	-20...+85°C
Storage temperature	-40...+85°C
Accessories (optionally)	Connection set (PVC-hose 2 m Ø 6 with 2 ABS nippels and 4 screws) and snap-on plastic brackets
Installation	Screw fastening
Installation position	Preferred vertical
Standards	CE-conformity, RoHS, EN1854 class A. Models available on request with UL508, CSA, ATEX approvals.
Optional	multiply packing (45 pcs/cardboard), models with range in mbar, UL / CSA approval (not available for IP65 models), IP65 protection, ATEX directive, low voltage version max. 0,1 A, 24 VDC, NBR diaphragm



Models	Measuring range	Repeatability	Differential*
PA1	20...300 Pa (0,2...3 mbar)	±5%, min. ±5 Pa	10 Pa (0,1 mbar)
PA2	30...400 Pa (0,3...4 mbar)	±5%, min. ±5 Pa	15 Pa (0,15 mbar)
PA3	50...500 Pa (0,5...5 mbar)	±2,5%, min. ±5 Pa	20 Pa (0,2 mbar)
PA4	200...1000 Pa (2...10 mbar)	±1%, min. ±5 Pa	100 Pa (1 mbar)
PA5	500...2500 Pa (5...25 mbar)	±1%	150 Pa (1,5 mbar)
PA6	1000...5000 Pa (10...50 mbar)	±1%	250 Pa (2,5mbar)
PA7	100...1000 Pa (1...10 mbar)	±2,5%, min. ±5 Pa	50 Pa (0,5 mbar)
PA8	50...700 Pa (0,5...7 mbar)	±2,5%, min. ±5 Pa	20 Pa (0,2 mbar)
Accessories:	APA1 Snap-on plastic bracket, L-shaped APA2 Snap-on plastic bracket, S-shaped APA3 PVC-hose 2 m Ø 6 with 2 ABS nippels and 4 screws		

*typically, at beginning of setting range

Switching pressure specifications apply to vertical installation which is also the recommended position with pressure-pipe connections pointing downwards. If the switches are installed horizontally with the tab terminals uppermost, the switching values are approx. 20 Pa higher.



Order matrix

Configurable pressure ranges	20...300 Pa	(0,2...3 mbar)	PA	1						
	30...400 Pa	(0,3...4 mbar)		2						
	50...500 Pa	(0,5...5,0 mbar)		3						
	200...1000 Pa	(2...10 mbar)		4						
	500...2,5 kPa	(5...25 mbar)		5						
	1...5 kPa	(10...50 mbar)		6						
	0,1... 1 kPa	(1... 10 mbar)		7						
	50...700 Pa	(0,5...7,0 mbar)		8						
Unit of measure	Pascal									
	Millibar				B					
Protetion	IP54									
	IP65					G				
Low voltage version	low voltage version max. 0,1 A, 24 VDC						LC			
Approval	Standard									
	UL							UL		
Directive	ATEX (II 2G Ex ia IIB T4 Gb / 2D Ex ia IIIB T135°C Db)*								X	
Packaging	Unit									
	45 pcs packaging									M

* Electrical rating: 2G: max 60 mA / 30 VDC or 100 mA 24 VDC
2D: max 60 mA / 30 VDC 0,6 W

Electrical wirings

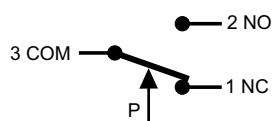

Dimensions (mm)

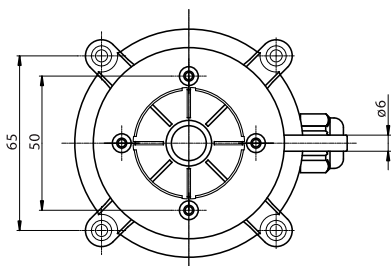

APA1 Snap-on plastic bracket, L-shaped

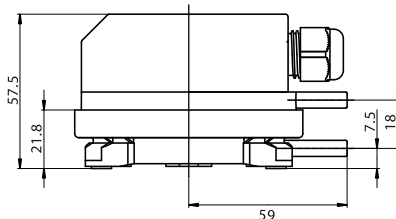
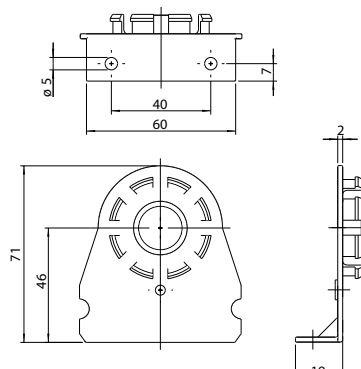

APA2 Snap-on plastic bracket, S-shaped

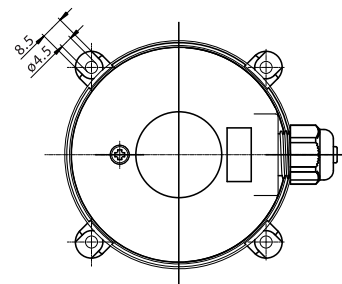
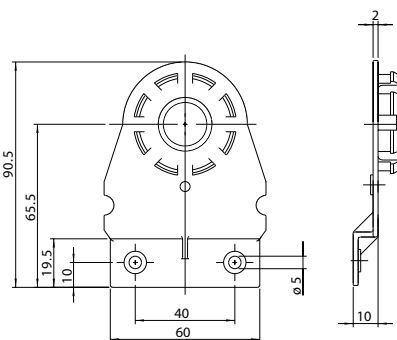

ABS nipple (part of APA3)

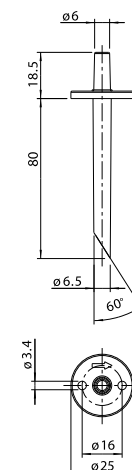

Description

The MM liquid column manometer is engineered for HVAC/R applications. The device detects air and non-corrosive gas pressure and provides a clear analog display of the measured values. It is designed with a reservoir to protect the manometer liquid from leaking into the duct during overpressure situation. It is provided with screws, 2 meters of pipe, labels and a bottle of red liquid.

Technical specifications

Gas	air and non-corrosive gas
Range	see schedule
Accuracy	see schedule
Material	white ABS housing, cover PMMA
Max working pressure	200 kPa
Working temperature	-40...+60 °C
Gauge fluid	Isopar M, colour red 0.786 kg/dm (15°C)
Dimensioni	190x153x45 mm
Standards	CE conformity, RoHS

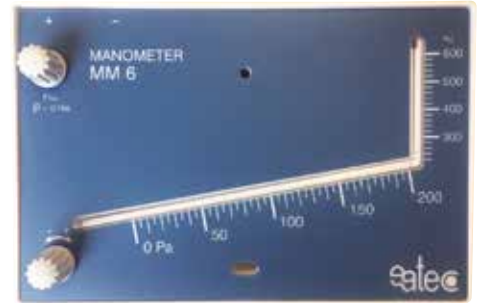

Model	Range	Accuracy	Liquid
MM6	0...200...600 Pa	0...200 Pa ±5%, 200...600 Pa ±25%	Red

Installation

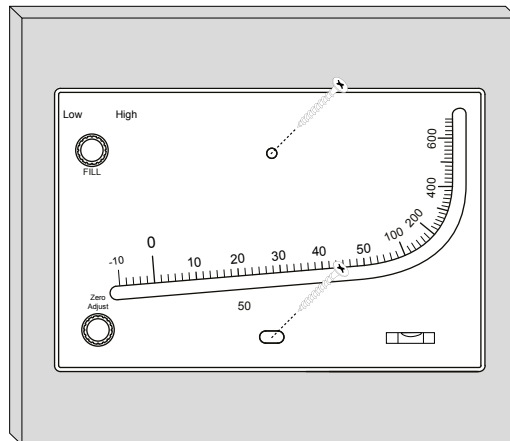

- 1) Mount the device horizontally in the desired location.
- 2) Unscrew the zero adjustment knob (lower one) so that it is completely open and then turn one round backwards. Open the fill plug (upper one) and pour in the gauge fluid until it reaches the zero on the scale. Finetune with the zero adjustment knob until the fluid is exactly at the zero level. Screw the fill plug back to its place.
- 3) Connect the pressure tubes. Connect positive pressure to port labeled "+" and negative pressure to port "-"

SAFETY: Product equipped with integral reservoir to prevent gauge fluid leakage during overpressure situation.

NOTE! Use only the liquid supplied with the device to ensure accuracy and performance.



orangeline

damper actuators

Description

Damper actuator serie S2 to operate and position air dampers in HVAC systems.

- For air dampers up to approx. 0.5 m²
- Nominal voltage 24 Vac/dc and 230 Vac
- Control: Open-close or 3-point and proportional
- Characteristics: universal spindle clamp for easy direct mounting, shaft dimensions Ø 6 to 15,5 mm round / 5 to 11 mm square, minimum shaft length 35 mm, anti-rotation bracket provided for stability, adjustable angle of rotation with mechanical end stops, 0,9 m cable connection, manual override with push-button possible (the gear train is disengaged for as long as the button is pressed), the actuator is overload protected, requires no limit switches and automatically stops when the end is reached. Operate the manual control without applying excessive force, keeping the release button pressed for the entire stroke of movement. Rotate slowly and smoothly, avoiding jerky movements or sudden changes in direction.



Technical features

Actuator model		S2A	S2B	S2AM	S2BM
Damper area	m ²		0.5		
Nominal torque	Nm		2		
Power supply	V	24 AC/DC	100...240 AC	24 AC/DC	100...240 AC
Frequency	Hz		50/60		
Power consumption					
- in operation	W	2,0	2,8	2,0	2,8
- at rest	W	0,5	0,7	0,5	0,7
- for wire sizing	VA		4,5		
Running time	s		20...45		
Sound power level	max. db (A)		45		
Control signal		2-3 point	2-3 point	0...10 V DC	0...10 V DC
Auxiliary switch rating			3 (1,5) A, 250 VAC		
Life Cycle	cycles		60.000		
Rotation angle			max.95°		
Rotation way			L/R switch		
Protection class			II		
Protection degree			IP54		
Working range °C			-20...+70° C		
Working range % RH			5...95% RH, non-condensating		
Storage temperature			-40...+70° C		
Maintenance			free		
Weight	g		600		
Standards			CE-conformity, RoHs		
Option			suffix S for models with 1 SPDT auxiliary switch		



Electrical wirings

Wiring diagram

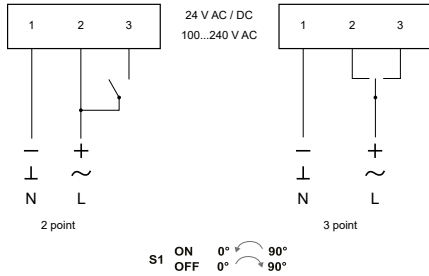

Wiring diagram
proportional

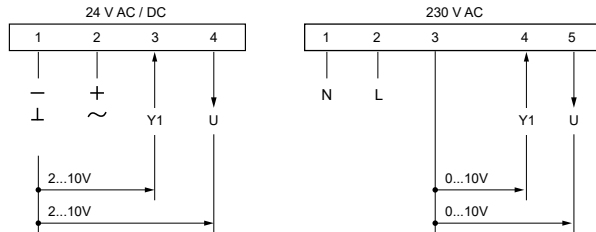

Auxiliary switch

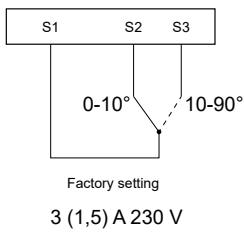

Setting

Change of rotation way

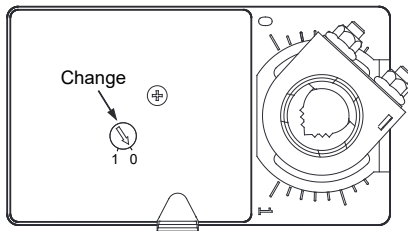

To reverse the rotation, use the dedicated tool (if supplied) without applying force.

Angle of rotation limiting

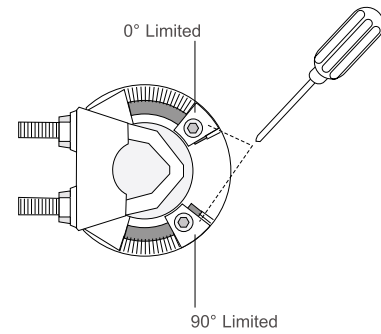

Dimensions (mm)

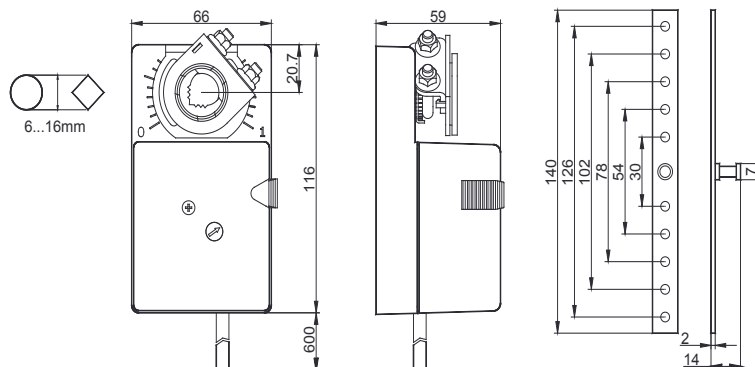

Description

- Damper actuator serie S4 to operate and position air dampers in HVAC systems.
- For air dampers up to approx. 1 m²
- Nominal voltage 24 Vac/dc and 230 Vac
- Control: Open-close or 3-point and proportional
- Characteristics: universal spindle clamp for easy direct mounting, shaft dimensions Ø 10 to 16 mm round / 10 to 12 mm square, minimum shaft length 50 mm, anti-rotation bracket provided for stability, manual over ride by push button, selectable direction of rotation, adjustable angle of rotation with mechanical end stops, manual override with push-button possible (the gear train is disengaged for as long as the button is pressed), the actuator is overload protected, requires no limit switches and automatically stops when the end is reached. Operate the manual control without applying excessive force, keeping the release button pressed for the entire stroke of movement. Rotate slowly and smoothly, avoiding jerky movements or sudden changes in direction.



Technical features

Actuator model		S4A	S4B	S4AM	S4BM
Damper area	m ²		1		
Nominal torque	Nm		4		
Power supply	V	24 AC/DC	100...240 AC	24 AC/DC	100...240 AC
Frequency	Hz		50/60		
Power consumption					
- in operation	W	2.2	3.2	2.2	3.2
- at rest	W	0.5	0.7	0.5	0.7
- for wire sizing	VA	4.4	6.4	4.4	6.4
Running time	s		45		
Sound power level	max. db (A)		45		
Control signal		2-3 point	2-3 point	0(2)...10 V DC 0(4)...20 mA	0(2)...10 V DC 0(4)...20 mA
Auxiliary switch rating			3 (1.5) A, 250 V AC		
Life Cycle	cycles		60.000		
Rotation angle					
- operating			0-90°		
- limitation			5-85° (steps of 5°)		
Protection class			II		
Protection degree			IP54		
Working range °C			-20...+70° C		
Working range RH			5...95% RH, non-condensating		
Storage temperature			-40...+70° C		
Maintenance			free		
Weight	g	900	1000	1000	900
Standards			CE-conformity, RoHs		
Option			suffix S for models with 2 SPDT auxiliary switches		



Electrical wirings for models at 2 / 3 point

Wiring diagram

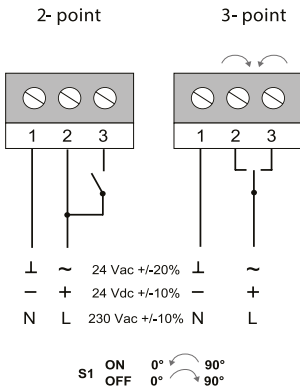

Auxiliary switches

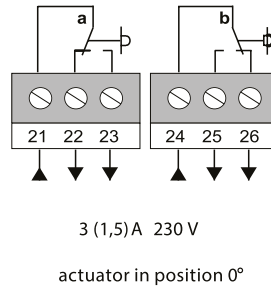

Parallel connections

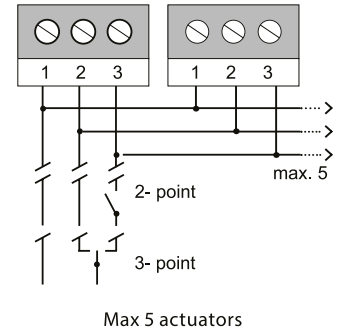

Settings

Changing direction of rotation

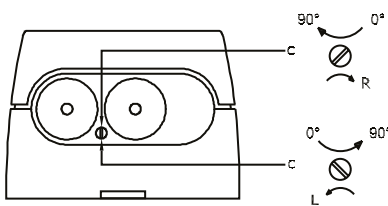

Auxiliary switch adjustment

Factory setting:
 switch a at 10° - switch b at 80°
 The switching position can be changed manually.

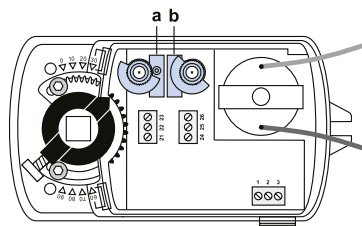

Angle of rotation limiting

The angle of rotation at 90° can be reduced by up to 30° from each end position with screw 1 and 2.

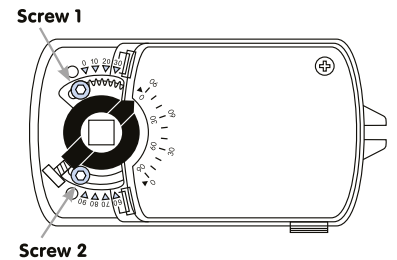

Electrical wirings for proportional models

Wiring diagram

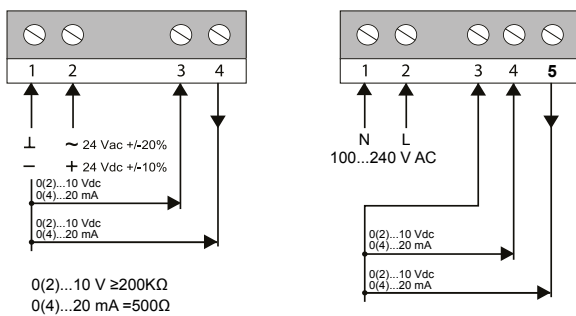

DIP settings

DIP 1 Feedback signal



OFF: 0(2)...10 V
 ON: 0(4)...20 mA

DIP 2 Input signal starting point



OFF: 0...10 V o 0...20 mA
 ON: 2...10 V o 4...20 mA

DIP 3 Input signal



OFF: 0(2)...10 V
 ON: 0(4)...20 mA

DIP 4 free

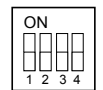

Dimensions (mm)

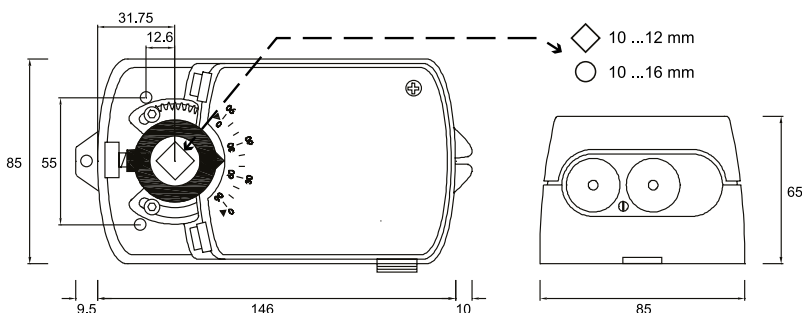

Description

Damper actuator serie S8 to operate and position air dampers in HVAC systems.

- For air dampers up to approx. 1,5 m²
- Nominal voltage 24 Vac/dc and 100...240 Vac
- Control: Open-close or 3-point and proportional
- Characteristics: universal spindle clamp fo easy direct mounting, shaft dimensions Ø 10 to 20 mm round / 10 to 16 mm square, minimum shaft length 50 mm, anti-rotation bracket provided for stability, manual over ride by push button, selectable direction of rotation, adjustable angle of rotation, parallel connection up to 10 actuators, manual override with push-button possible (the gear train is disengaged for as long as the button is pressed), the actuator is overload protected, requires no limit switches and automatically stops when the end is reached.



Technical features

Actuator model		S8A	S8B	S8AM	S8BM
Damper area	m ²		1,5		
Nominal torque	Nm		8		
Power supply	V	24 AC/DC	100...240 AC	24 AC/DC	100...240 AC
Frequency	Hz		50/60		
Power consumption					
- in operation	W		4.5		
- at rest	W	0.5	0.7	0.5	0.7
- for wire sizing	VA		7.0		
Running time	s		30...60		
Sound power level	max. db (A)		45		
Control signal		2-3 point	2-3 point	0(2)...10 V DC 0(4)...20 mA	0(2)...10 V DC 0(4)...20 mA
Auxiliary switch rating			3 (1.5) A, 230 V AC		
Life Cycle	cicli		60.000		
Rotation angle					
- operating			0-90°		
- limitation			5-85° (steps of 5°)		
Protection class		III	II	III	II
Protection degree			IP54		
Working range °C			-20...+70° C		
Working range RH			5...95% RH, non-condensating		
Storage temperature			-40...+80° C		
Maintenance			free		
Weight	g		<1300		
Standards			CE-conformity, RoHs		
Option			suffix S for models with 2 SPDT auxiliary switches		



Electrical wirings for models at 2 / 3 points

Wiring diagram

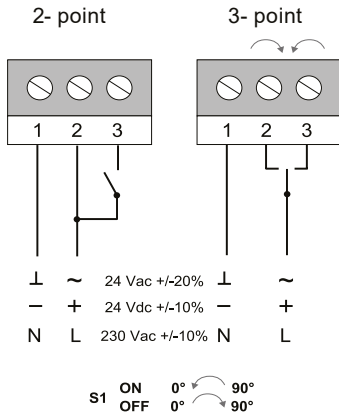

Auxiliary switches

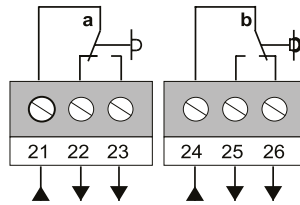

Parallel connections

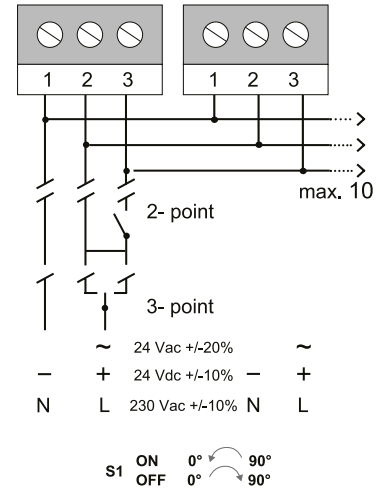

Electrical wirings for proportional models

Wiring diagram 230 V AC

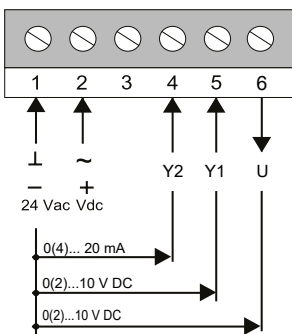

Wiring diagram 24 V AC

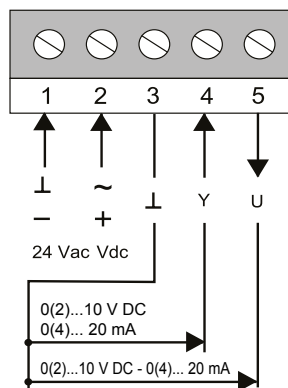

Auxiliary switches

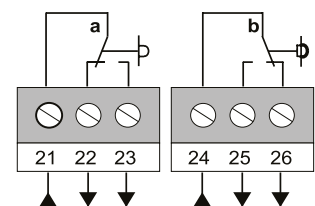

Settings DIP switches

DIP 1
Feedback signal

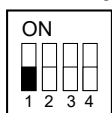

OFF: 0(2)...10 V
 ON: 0(4)...20 mA

DIP 2
Input signal starting point

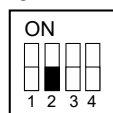

OFF: 0...10 V o 0...20 mA
 ON: 2...10 V o 4...20 mA

DIP 3
Input signal

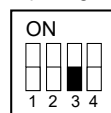

OFF: 0(2)...10 V
 ON: 0(4)...20 mA

DIP 4
Rotation direction

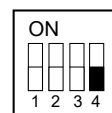

OFF: With the increase of the signal,
 the actuator rotate counterclockwise
 ON: With the increase of the signal,
 the actuator rotate clockwise

S2
Rotation direction

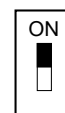

option



Auxiliary switch adjustment

Factory setting:
switch a at 10°
switch b at 80°
The switching position can
be changed manually.

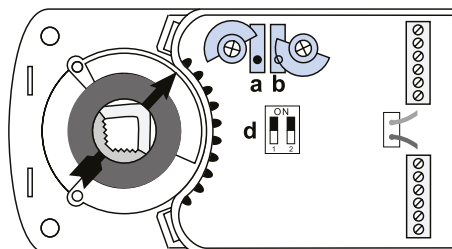

Angle of rotation limiting

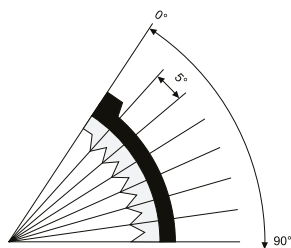

Adapter release

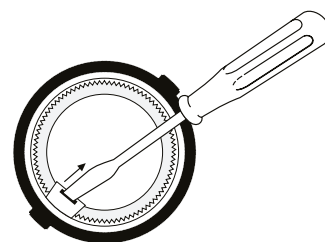

■ Dimensions (mm)

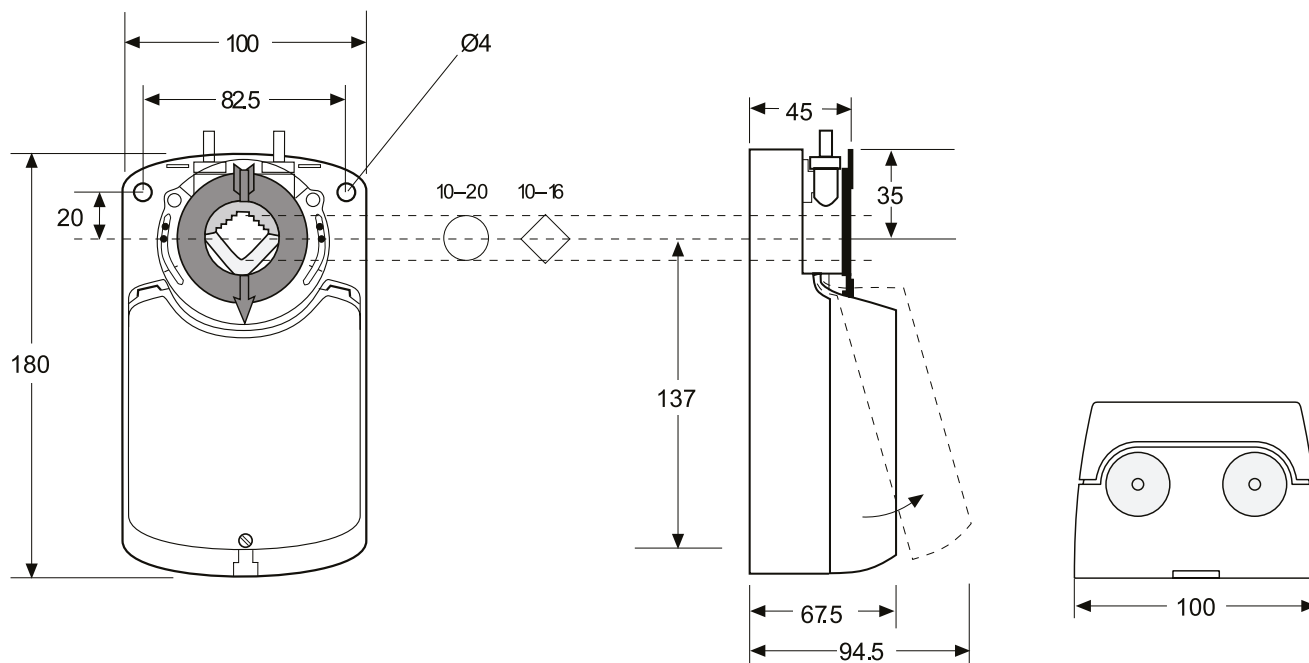

Description

Damper actuator serie S16 to operate and position air dampers in HVAC systems.

- For air dampers up to approx. 3 m²
- Nominal voltage 24 Vac/dc and 100...230 Vac
- Control: Open-close or 3-point and proportional
- Characteristics: universal spindle clamp fo easy direct mounting, shaft dimensions Ø 10 to 20 mm round / 10 to 16 mm square, minimum shaft length 50 mm, anti-rotation bracket provided for stability, manual over ride by push button, selectable direction of rotation, adjustable angle of rotation, parallel connection up to 10 actuators, manual override with push-button possible (the gear train is disengaged for as long as the button is pressed), the actuator is overload protected, requires no limit switches and automatically stops when the end is reached.



Technical features

Actuator model		S16A	S16B	S16AM	S16BM
Damper area	m ²			3	
Nominal torque	Nm			16	
Power supply	V	24 AC/DC	100...240 AC	24 AC/DC	100...240 AC
Frequency	Hz			50/60	
Power consumption					
- in operation	W			4.5	
- at rest	W	0.5	0.7	0.5	0.7
- for wire sizing	VA			7.0	
Running time	s			70...100	
Sound power level	db (A)			45	
Control signal		2-3 point	2-3 point	0(2)...10 V DC 0(4)...20 mA	0(2)...10 V DC 0(4)...20 mA
Auxiliary switch rating				3 (1.5) A, 230 V AC	
Life Cycle	cycles			60.000	
Rotation angle					
- operating				0-90°	
- limitation				5-85° (steps of 5°)	
Protection class		III	II	III	II
Protection degree				IP54	
Working range °C				-20...+70° C	
Working range RH				5...95% RH, non-condensating	
Storage temperature				-40...+80° C	
Maintenance				free	
Weight	g			<1300	
Standards				CE-conformity, RoHs	
Option		suffix S for models with 2 SPDT auxiliary switches			



Electrical wirings for models at 2 / 3 points

Wiring diagram

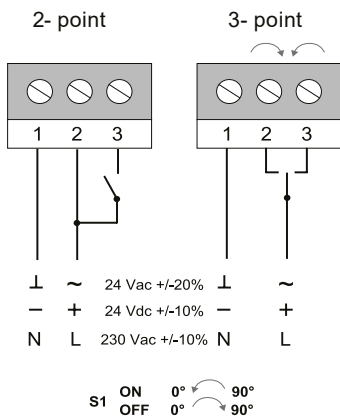

Auxiliary switches

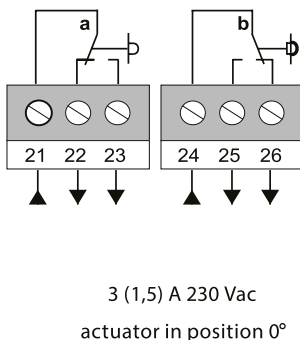

Parallel connections

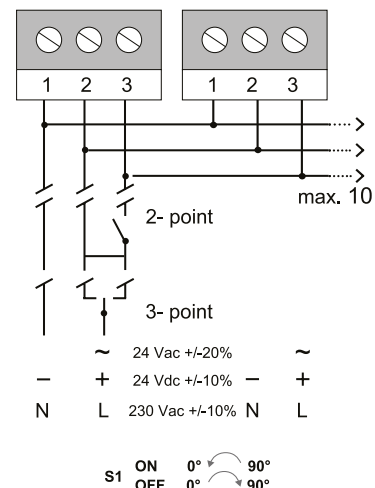

Electrical wirings for proportional models

Wiring diagram 230 V AC

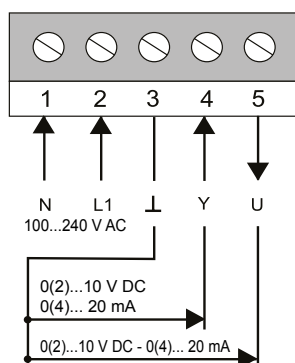

Wiring diagram 24 V AC

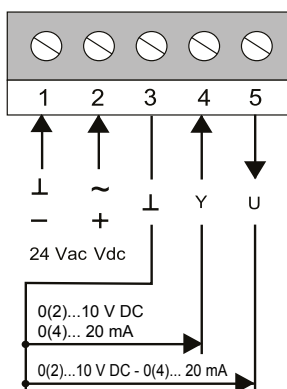

Auxiliary switches

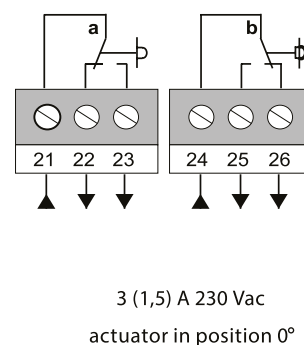

Settings DIP switches

DIP 1
Feedback signal

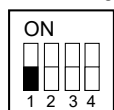

OFF: 0(2)...10 V
 ON: 0(4)...20 mA

DIP 2
Input signal starting point

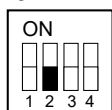

OFF: 0...10 V o 0...20 mA
 ON: 2...10 V o 4...20 mA

DIP 3
Input signal

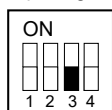

OFF: 0(2)...10 V
 ON: 0(4)...20 mA

DIP 4
Rotation direction

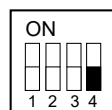

OFF: With the increase of the signal,
 the actuator rotate counterclockwise
 ON: With the increase of the signal,
 the actuator rotate clockwise

S2
Rotation direction

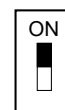

option

S16



Auxiliary switch adjustment

Factory setting:
switch a at 10°
switch b at 80°
The switching position can
be changed manually.

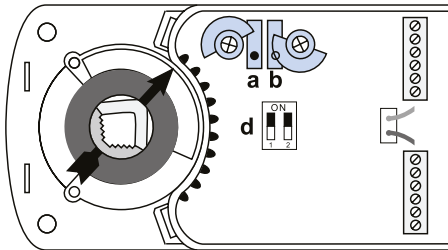

Angle of rotation limiting

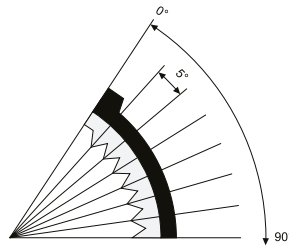

Adapter release

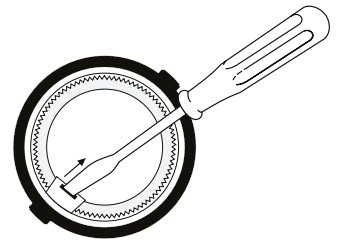

■ Dimensions (mm)

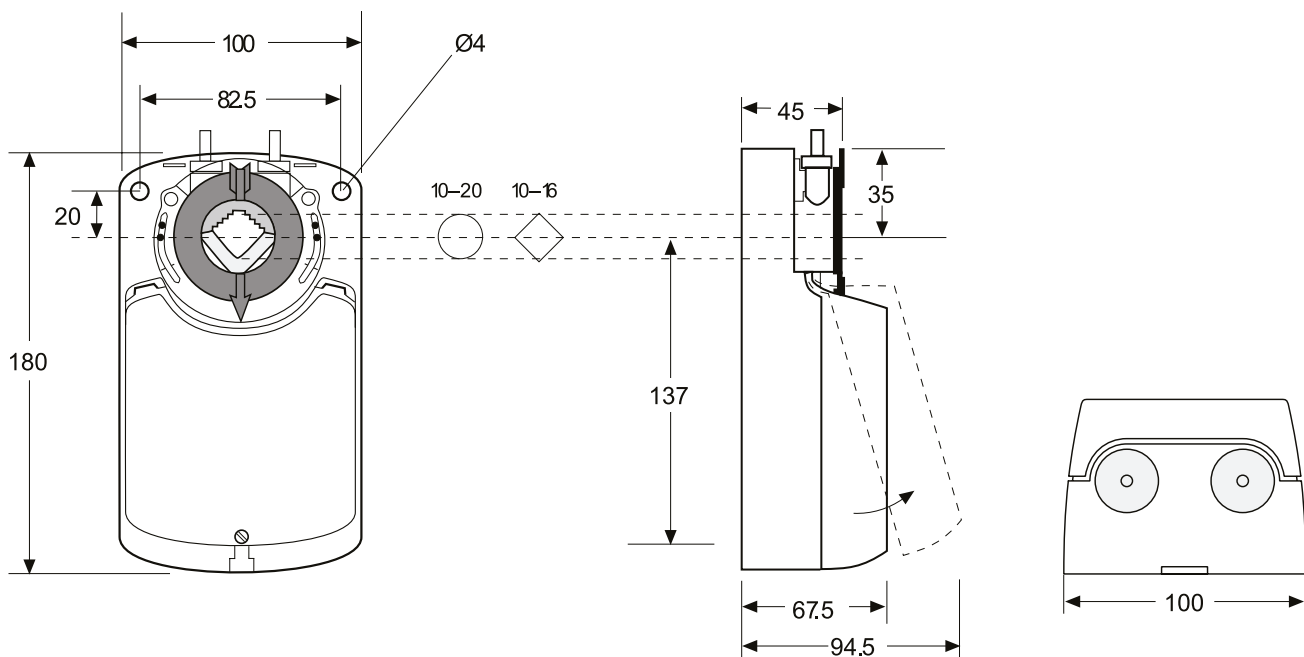

Description

Damper actuator serie S24 to operate and position air dampers in HVAC systems.

- For air dampers up to approx. 4.5 m²
- Nominal voltage 24 Vac/dc and 100...240 Vac
- Control: Open-close or 3-point and proportional
- Characteristics: universal spindle clamp fo easy direct mounting, shaft dimensions Ø 10 to 20 mm round / 10 to 16 mm square, minimum shaft length 50 mm, anti-rotation bracket provided for stability, manual over ride by push button, selectable direction of rotation, adjustable angle of rotation, parallel connection up to 10 actuators, manual override with push-button possible (the gear train is disengaged for as long as the button is pressed), the actuator is overload protected, requires no limit switches and automatically stops when the end is reached.



Technical features

Actuator model		S24A	S24B	S24AM	S24BM
Damper area	m ²		4.5		
Nominal torque	Nm		24		
Power supply	V	24 AC/DC	100...240 AC	24 AC/DC	100...240 AC
Frequency	Hz		50/60		
Power consumption					
- in operation	W		4,5		
- at rest	W	0,5	0,7	0,5	0,7
- for wire sizing	VA		7,0		
Running time	s		130...160		
Sound power level	db (A)		45		
Control signal		2-3 point	2-3 point	0(2)...10 V DC 0(4)...20 mA	0(2)...10 V DC 0(4)...20 mA
Auxiliary switch rating			3 (1,5) A, 230 V AC		
Life Cycle	cycles		60.000		
Rotation angle					
- operating			0-90°		
- limitation			5-85° (steps of 5°)		
Protection class		III	II	III	II
Protection degree			IP54		
Working range °C			-20...+70° C		
Working range RH			5...95% RH, non-condensating		
Storage temperature			-40...+80° C		
Maintenance			free		
Weight	g		<1300		
Standards			CE-conformity, RoHs		
Option			suffix S for models with 2 SPDT auxiliary switches		



Electrical wirings for models at 2 / 3 points

Wiring diagram

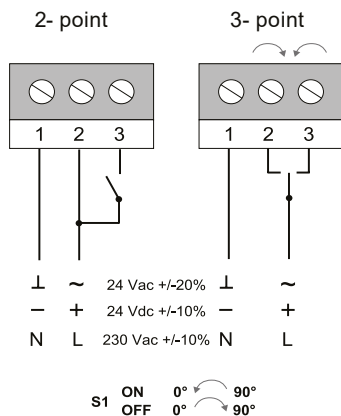

Auxiliary switches

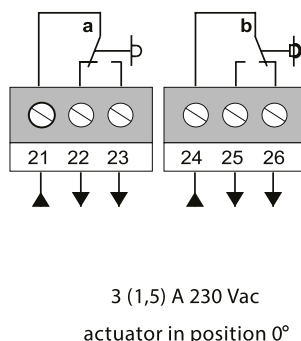

Parallel connections

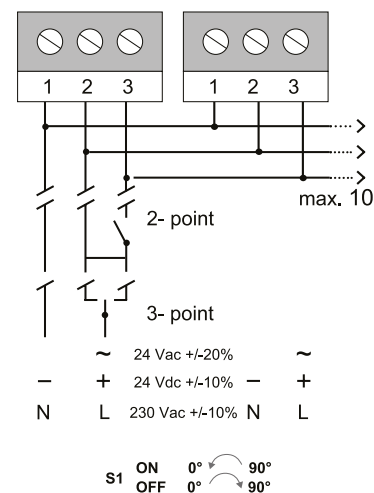

Electrical wirings for proportional models

Wiring diagram 230 V AC

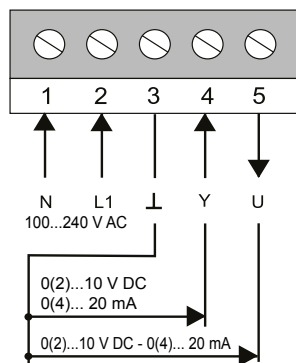

Wiring diagram 24 V AC

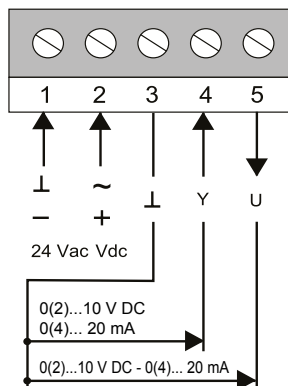

Auxiliary switches

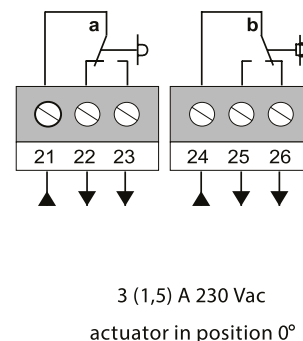

Settings DIP switches

DIP 1
Feedback signal

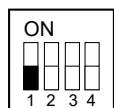

OFF: 0(2)...10 V
ON: 0(4)...20 mA

DIP 2
Input signal starting point

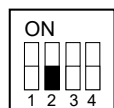

OFF: 0...10 V o 0...20 mA
ON: 2...10 V o 4...20 mA

DIP 3
Input signal

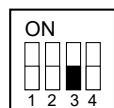

OFF: 0(2)...10 V
ON: 0(4)...20 mA

DIP 4
Rotation direction

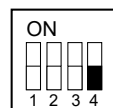

OFF: With the increase of the signal, the actuator rotate counterclockwise
ON: With the increase of the signal, the actuator rotate clockwise

S2
Rotation direction



option



Auxiliary switch adjustment

Factory setting:
 switch a at 10°
 switch b at 80°
 The switching position can
 be changed manually.

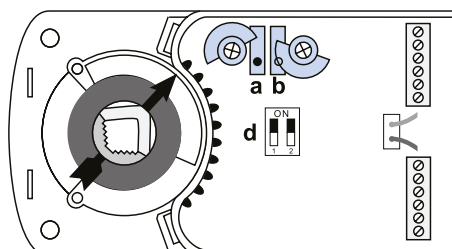

Angle of rotation limiting

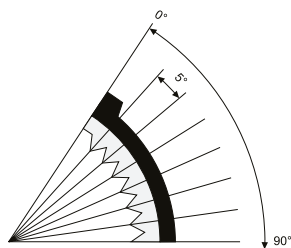

Adapter release

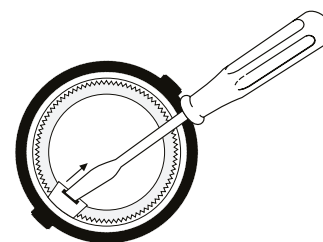

■ Dimensions (mm)

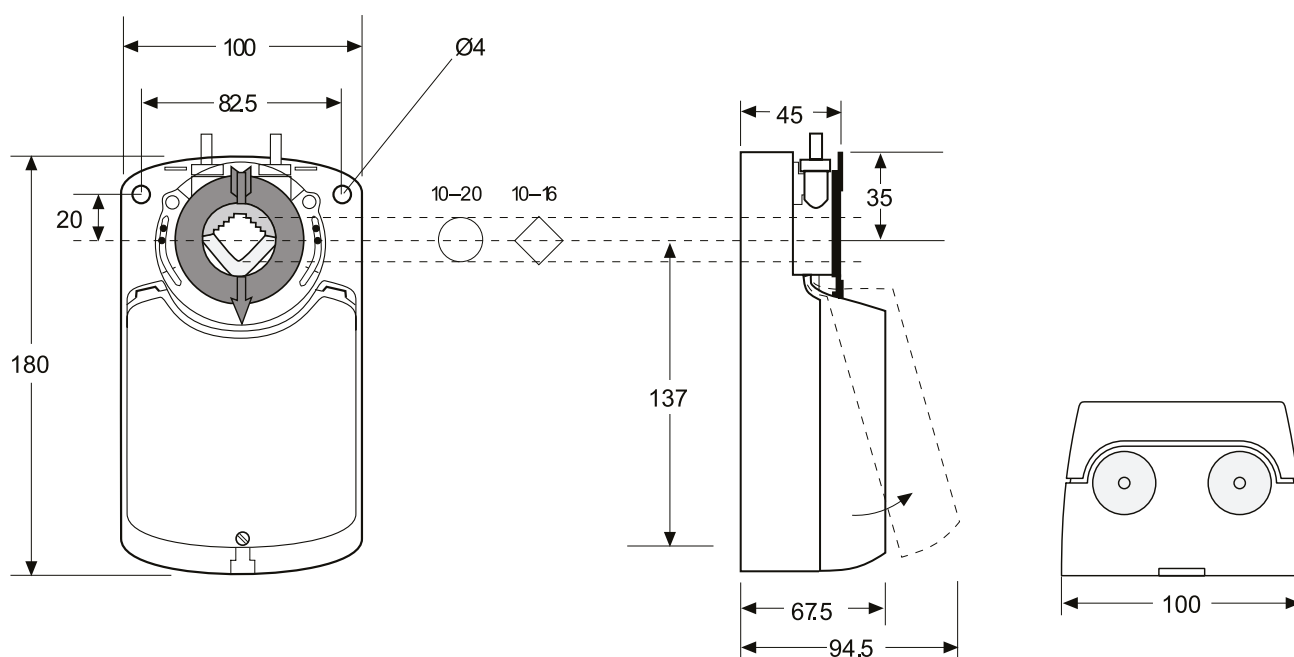

Description

Damper actuator serie S32 to operate and position air dampers in HVAC systems.

- For air dampers up to approx. 6 m²
- Nominal voltage 24 Vac/dc and 100...240 Vac
- Control: Open-close or 3-point and proportional
- Characteristics: universal spindle clamp fo easy direct mounting, shaft dimensions Ø 10 to 20 mm round / 10 to 16 mm square, minimum shaft length 50 mm, anti-rotation bracket provided for stability, manual over ride by push button, selectable direction of rotation, adjustable angle of rotation, parallel connection up to 10 actuators, manual override with push-button possible (the gear train is disengaged for as long as the button is pressed), the actuator is overload protected, requires no limit switches and automatically stops when the end is reached.



Technical features

Actuator model		S32A	S32B	S32AM	S32BM
Damper area	m ²		6		
Nominal torque	Nm		32		
Power supply	V	24 AC/DC	100...240 AC	24 AC/DC	100...240 AC
Frequency	Hz		50/60		
Power consumption					
- in operation	W		4,5		
- at rest	W	0,5	0,7	0,5	0,7
- for wire sizing	VA		7,0		
Running time	s		180		
Sound power level	db (A)		45		
Control signal		2-3 point	2-3 point	0(2)...10 V DC 0(4)...20 mA	0(2)...10 V DC 0(4)...20 mA
Auxiliary switch rating			3 (1,5) A, 230 V AC		
Life Cycle	cycles		60.000		
Rotation angle					
- operating			0-90°		
- limitation			5-85° (steps of 5°)		
Protection class		III	II	III	II
Protection degree			IP54		
Working range °C			-20...+70° C		
Working range RH			5...95% RH, non-condensating		
Storage temperature			-40...+80° C		
Maintenance			free		
Weight	g		1300		
Standards			CE-conformity, RoHs		
Option			suffix S for models with 2 SPDT auxiliary switches		



Electrical wirings for models at 2 / 3 points

Wiring diagram

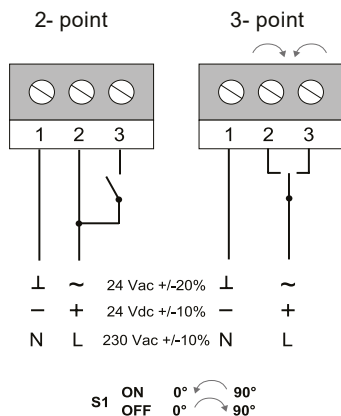

Auxiliary switches

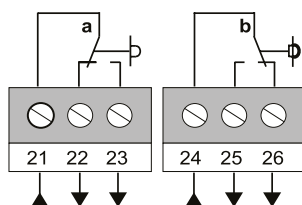

3 (1,5) A 230 Vac
actuator in position 0°

Parallel connections

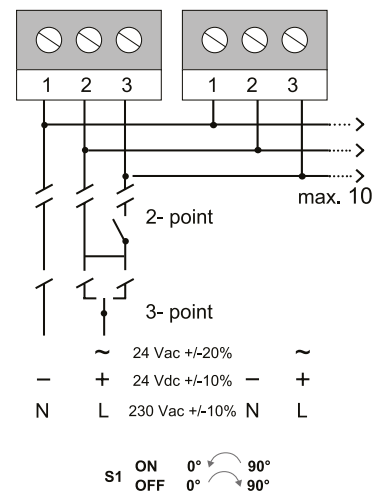

Electrical wirings for proportional models

Wiring diagram 230 V AC

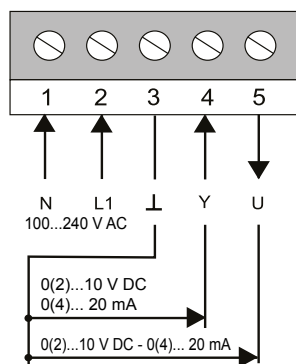

Wiring diagram 24 V AC

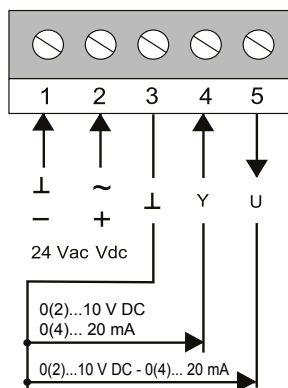

Auxiliary switches

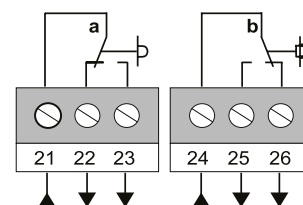

3 (1,5) A 230 Vac
actuator in position 0°

Settings DIP switches

DIP 1
Feedback signal

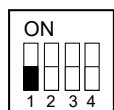

OFF: 0(2)...10 V
ON: 0(4)...20 mA

DIP 2
Input signal starting point

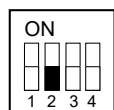

OFF: 0...10 V o 0...20 mA
ON: 2...10 V o 4...20 mA

DIP 3
Input signal

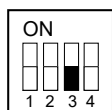

OFF: 0(2)...10 V
ON: 0(4)...20 mA

DIP 4
Rotation direction

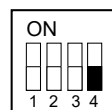

OFF: With the increase of the signal,
the actuator rotate counterclockwise
ON: With the increase of the signal,
the actuator rotate clockwise

S2
Rotation direction

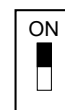

option



Auxiliary switch adjustment

Factory setting:
switch a at 10°
switch b at 80°
The switching position can
be changed manually.

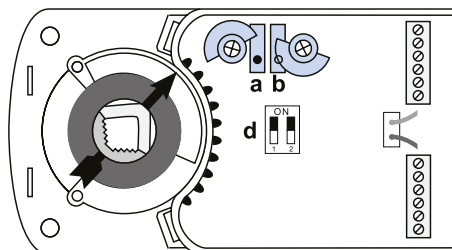

Angle of rotation limiting

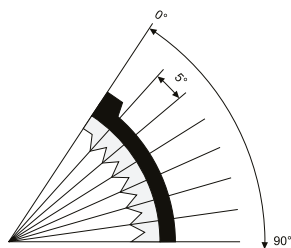

Adapter release

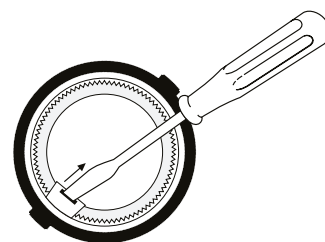

■ Dimensions (mm)

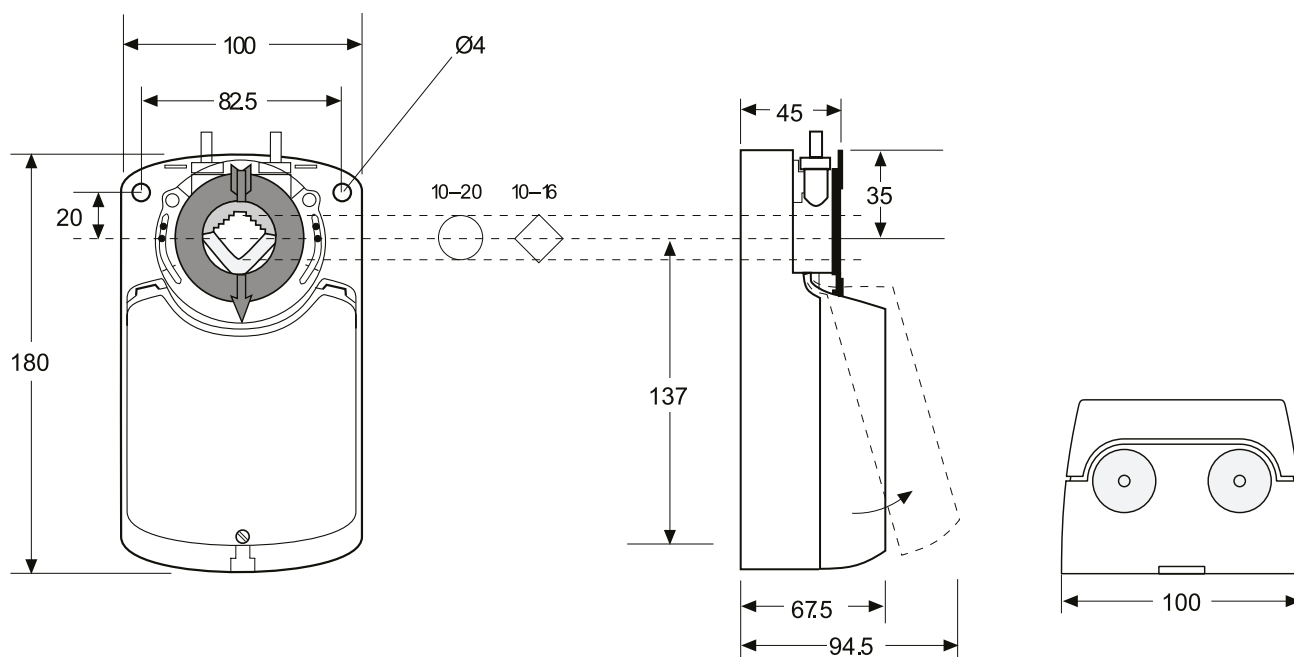

Damper actuators fast running, 8 Nm

S8F

Description

Damper actuator serie S8 to operate and position air dampers in HVAC systems.

- For air dampers up to approx. 1,5 m²
- Nominal voltage 24 Vac/dc and 100...240 Vac
- Control: Open-close or 3-point and proportional
- Characteristics: universal spindle clamp for easy direct mounting, shaft dimensions Ø 10 to 20 mm round / □ 10 to 16 mm square, minimum shaft length 50 mm, anti-rotation bracket provided for stability, manual over ride by push button, selectable direction of rotation, adjustable angle of rotation, parallel connection up to 10 actuators.



Technical features

Actuator model		S8AF	S8BF	S8AMF	S8BMF
Damper area	m ²			1,5	
Nominal torque	Nm			8	
Power supply	V	24 AC/DC	100...240 AC	24 AC/DC	100...240 AC
Frequency	Hz			50/60	
Power consumption					
- in operation	W			12	
- at rest	W	0.5	0.7	0.5	0.7
- for wire sizing	VA			7.0	
Running time	s			8	
Sound power level	max. db (A)			65	
Control signal		2-3 point	2-3 point	0(2)...10 V DC 0(4)...20 mA	0(2)...10 V DC 0(4)...20 mA
Auxiliary switch rating				3 (1.5) A, 230 V AC	
Life Cycle	cicli			60.000	
Rotation angle					
- operating				0-90°	
- limitation				5-85° (steps of 5°)	
Protection class		III	II	III	II
Protection degree				IP54	
Working range °C				-20...+70° C	
Working range RH				5...95% RH, non-condensating	
Storage temperature				-40...+80° C	
Maintenance				free	
Weight	g			<1300	
Standards				CE-conformity, RoHs	
Option				suffix S for models with 2 SPDT auxiliary switches	



Electrical wirings for models at 2 / 3 points

Wiring diagram

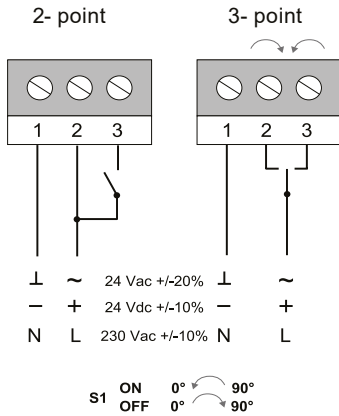

Auxiliary switches

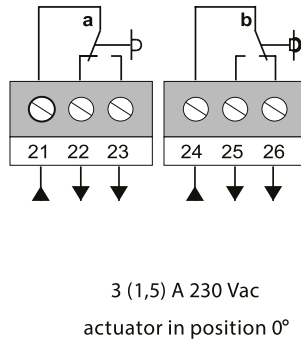

Parallel connections

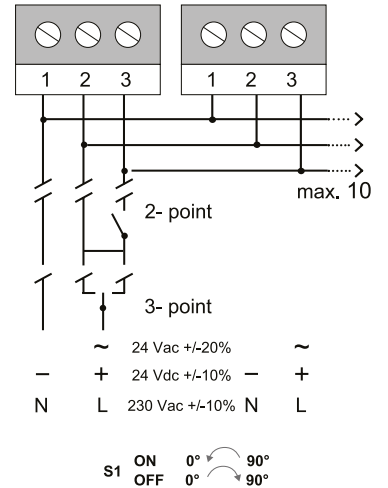

Electrical wirings for proportional models

Wiring diagram 230 V AC

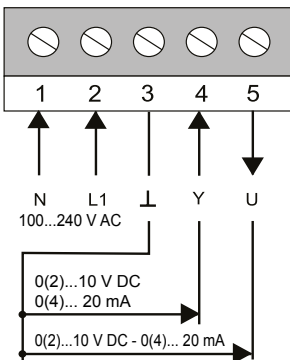

Wiring diagram 24 V AC

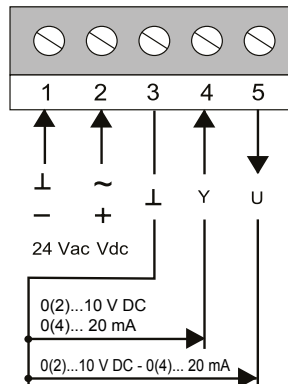

Auxiliary switches

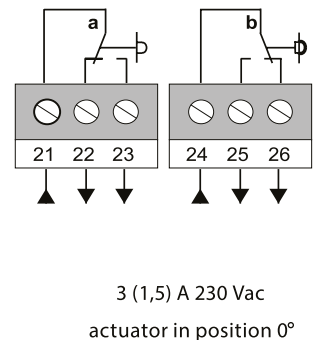

Settings

Setting DIP

DIP 1
 Feedback signal

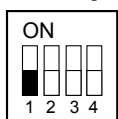

OFF: 0(2)...10 V
 ON: 0(4)...20 mA

DIP 2
 Input signal starting point

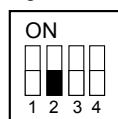

OFF: 0...10 V o 0...20 mA
 ON: 2...10 V o 4...20 mA

DIP 3
 Input signal

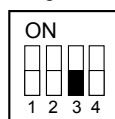

OFF: 0(2)...10 V
 ON: 0(4)...20 mA

DIP 4
 Rotation direction

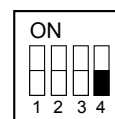

OFF: With the increase of the signal,
 the actuator rotate counterclockwise
 ON: With the increase of the signal,
 the actuator rotate clockwise



Auxiliary switch adjustment

Factory setting:

switch a at 10°

switch b at 80°

The switching position can be changed manually.

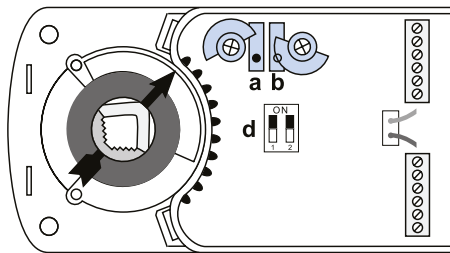

Angle of rotation limiting

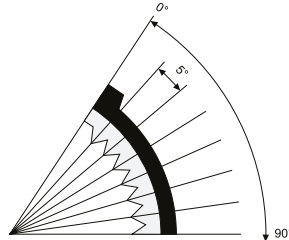

Adapter release

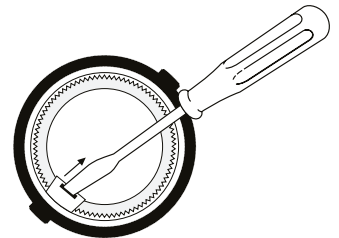

■ Dimensions (mm)

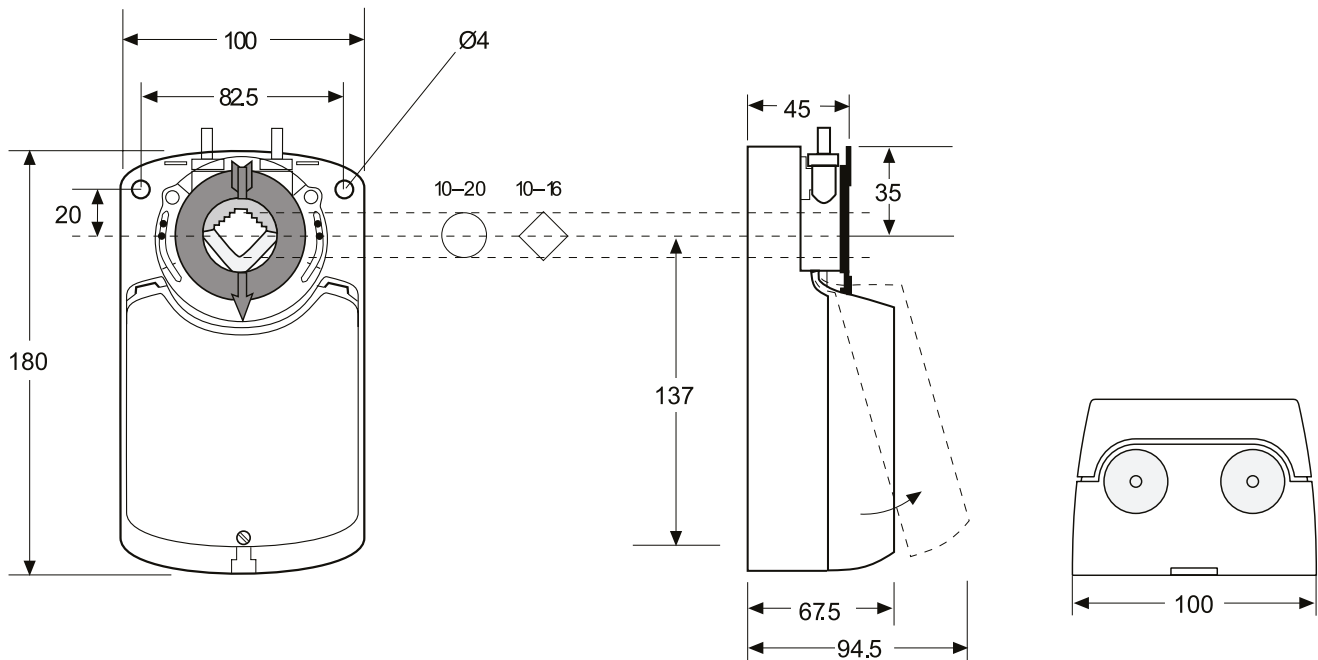

Damper actuators fast running, 16 Nm

S16F



Description

Damper actuator serie S16 to operate and position air dampers in HVAC systems.

- For air dampers up to approx. 3 m²
- Nominal voltage 24 Vac/dc and 100...240 Vac
- Control: Open-close or 3-point and proportional
- Characteristics: universal spindle clamp fo easy direct mounting, shaft dimensions Ø 10 to 20 mm round / □ 10 to 16 mm square, minimum shaft length 50 mm, anti-rotation bracket provided for stability, manual over ride by push button, selectable direction of rotation, adjustable angle of rotation, parallel connection up to 10 actuators.



Technical features

Actuator model		S16A	S16B	S16AM	S16BM
Damper area	m ²		3		
Nominal torque	Nm		16		
Power supply	V	24 AC/DC	100...240 AC	24 AC/DC	100...240 AC
Frequency	Hz		50/60		
Power consumption					
- in operation	W		12		
- at rest	W	0.5	0.7	0.5	0.7
- for wire sizing	VA		7.0		
Running time	s		16		
Sound power level	db (A)		65		
Control signal		2-3 point	2-3 point	0(2)...10 V DC 0(4)...20 mA	0(2)...10 V DC 0(4)...20 mA
Auxiliary switch rating			3 (1.5) A, 230 V AC		
Life Cycle	cycles		60.000		
Rotation angle					
- operating			0-90°		
- limitation			5-85° (steps of 5°)		
Protection class		III	II	III	II
Protection degree			IP54		
Working range °C			-20...+70° C		
Working range RH			5...95% RH, non-condensating		
Storage temperature			-40...+80° C		
Maintenance			free		
Weight	g		<1300		
Standards			CE-conformity, RoHs		
Option			suffix S for models with 2 SPDT auxiliary switches		



Electrical wirings for models at 2 / 3 points

Wiring diagram

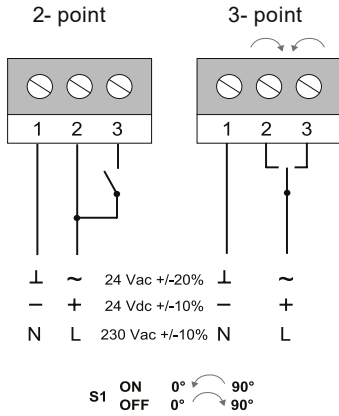

Auxiliary switches

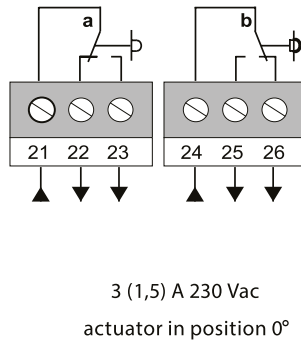

Parallel connections

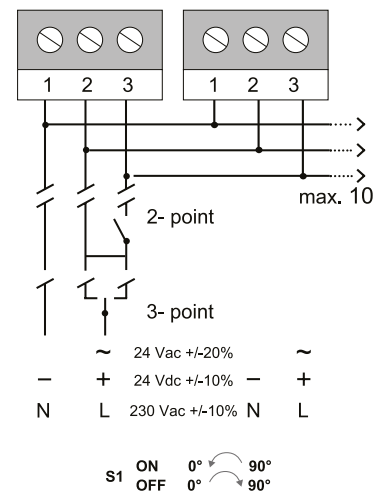

Electrical wirings for proportional models

Wiring diagram 230 V AC

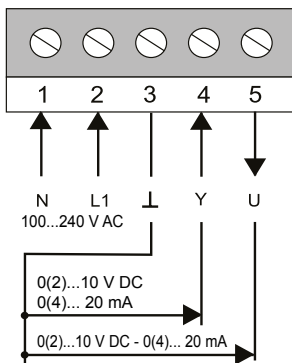

Wiring diagram 24 V AC

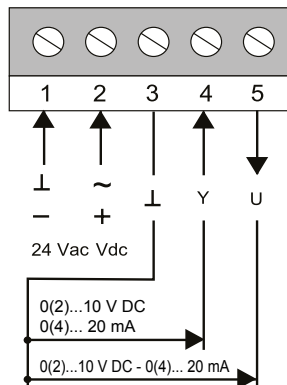

Auxiliary switches

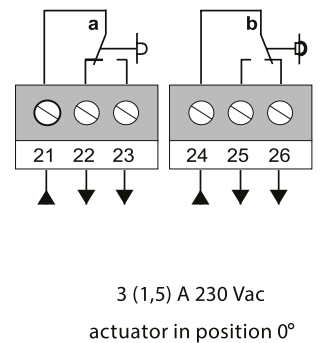

Settings

Setting DIP

DIP 1
 Feedback signal

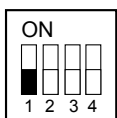

OFF: 0(2)...10 V
 ON: 0(4)...20 mA

DIP 2
 Input signal starting point

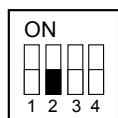

OFF: 0...10 V o 0...20 mA
 ON: 2...10 V o 4...20 mA

DIP 3
 Input signal

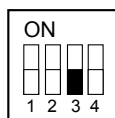

OFF: 0(2)...10 V
 ON: 0(4)...20 mA

DIP 4
 Rotation direction

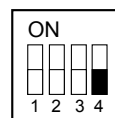

OFF: With the increase of the signal,
 the actuator rotate counterclockwise
 ON: With the increase of the signal,
 the actuator rotate clockwise

S16F



Auxiliary switch adjustment

Factory setting:

switch a at 10°

switch b at 80°

The switching position can be changed manually.

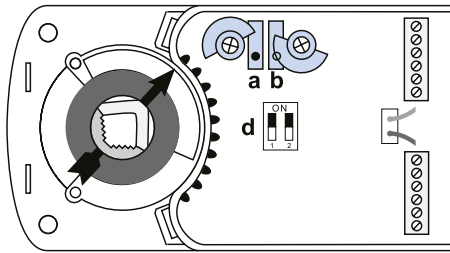

Angle of rotation limiting

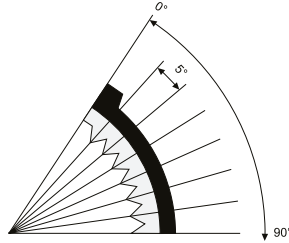

Adapter release

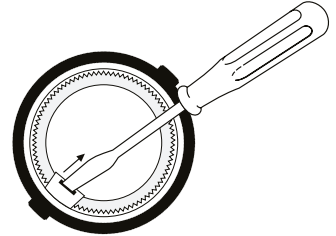

■ Dimensions (mm)

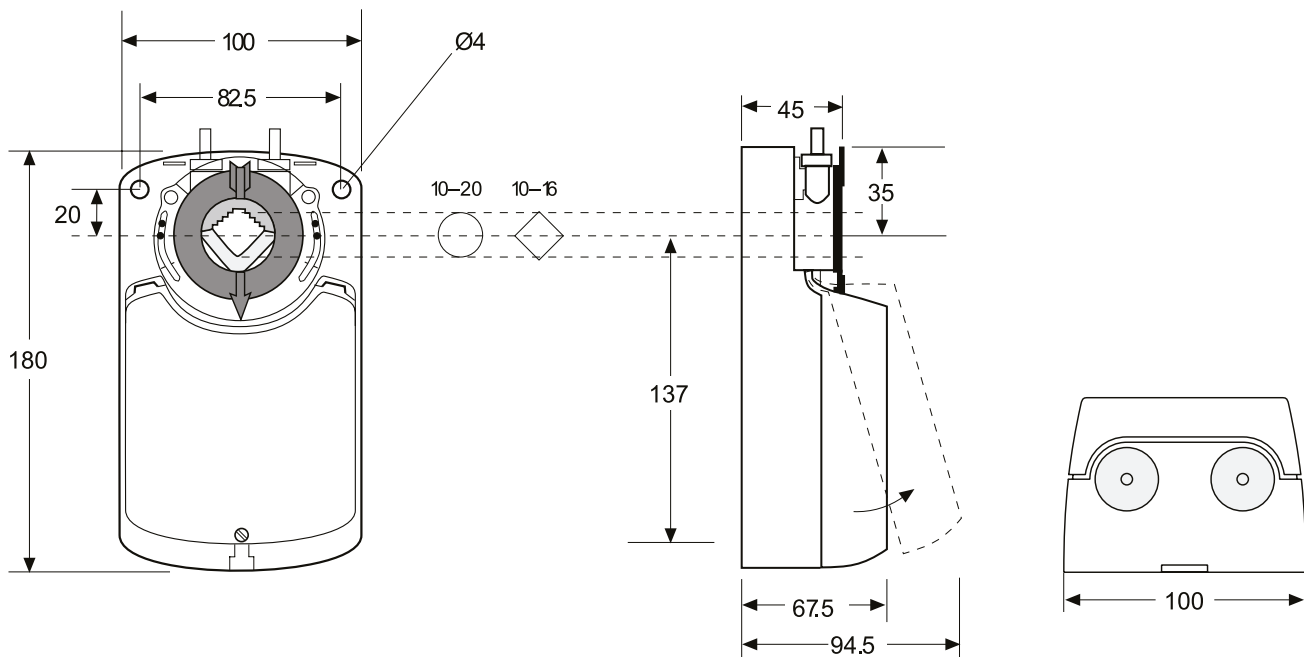

Spring-return damper actuator, 2,5 Nm

SR2

Description

Damper actuator serie SR2 to operate and position air dampers in HVAC systems.

- For air dampers up to approx. 0,5 m²
- Nominal voltage 24 Vac/dc and 230 Vac
- Control: 2-point, on-off and proportional
- Characteristics: universal spindle clamp for easy direct mounting, shaft dimensions max Ø 12 mm, □ 8x8mm minimum shaft length 80 mm, anti-rotation bracket provided for stability, selectable direction of rotation, adjustable angle of rotation, 1 m cable connection.



Technical features

Actuator model		SR2A	SR2AM	SR2B
Damper area	m ²		0,5	
Nominal torque	Nm		2,5	
Power supply	V	24 AC/DC	24 AC/DC	230 AC
Frequency	Hz		50/60	
Power consumption				
- in operation	W	2,5	2,5	2,5
- at rest	W		1,6	
Running time for motor	s		60 / 70	
Running time for spring	s		25 / 30	
Sound power level	db (A)		circa 50	
Control signal		2 point, on-off	0...10 V DC	2 point, on-off
Auxiliary switch rating			3 (1,5) A, AC 230 V	
Life Cycle	cycles		70.000	
Rotation angle				
- operating			90° (95° mechanical)	
- limitation			5-85° (steps of 5°)	
Protection class		III	III	II
Protection degree			IP54	
Working range °C			-20...+50° C	
Working range RH			5...95% RH, non-condensating	
Storage temperature			-30...+80° C	
Maintenance			free	
Weight	g		1000	
Standards			CE-conformity, RoHs	
Option		suffix S for models with 2 SPDT auxiliary switches		



Electrical wirings

Wiring diagram On/Off

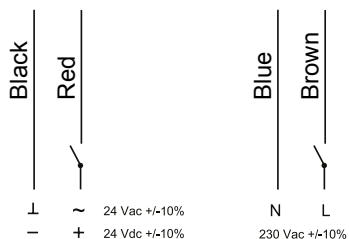

Wiring diagram proportional

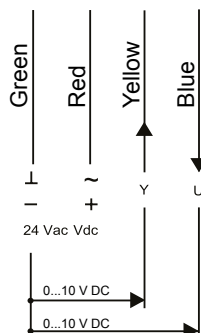

Auxiliary switches

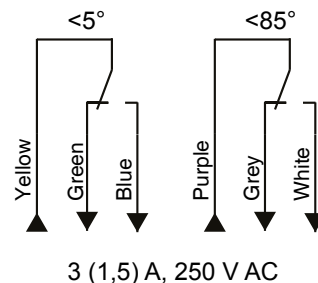

Settings

Limitation of rotation angle from 5° to 85°

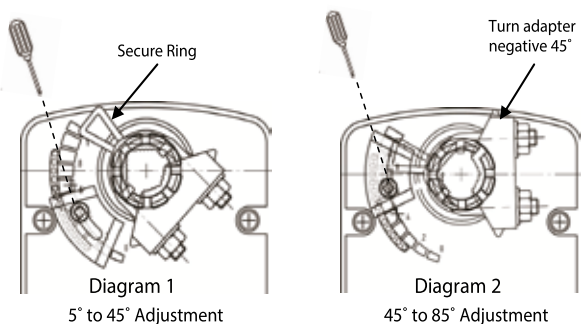

For 5° to 45° (diagram 1)

1. Loosen screw of the mechanical limiter plate.
2. Move the limiter plate to the appropriate position.
3. Tighten the screw.

For 45° to 85° (diagram 2)

1. Release the secure ring of the adapter.
2. Remove the adapter and turn negative 45° as shown.
3. Insert adapter and secure the adapter ring.
4. Loosen screw of the mechanical limiter plate.
5. Move the limiter plate to the appropriate position.
6. Tighten the screw.

Dimensions (mm)

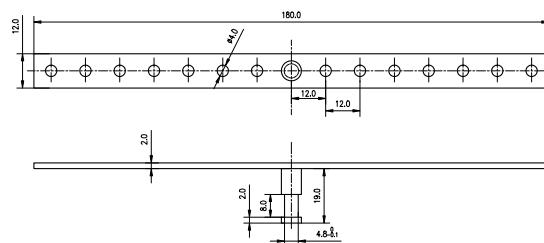
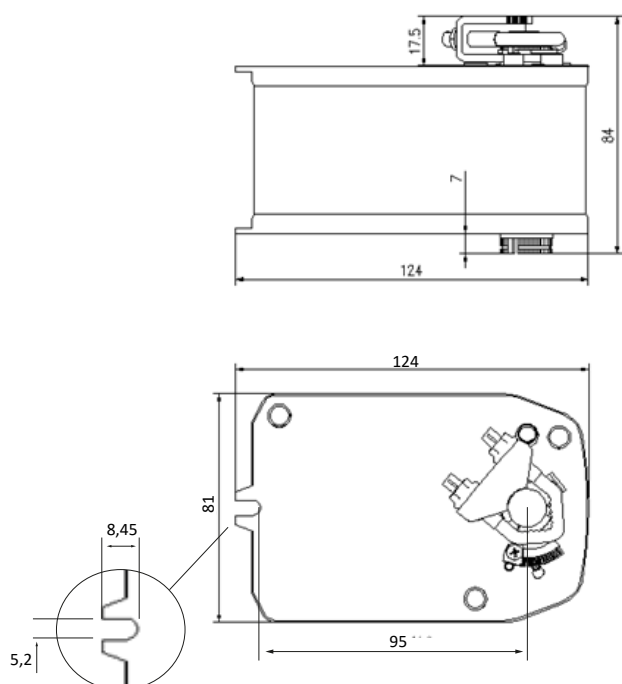

Description

Damper actuator serie SR3 to operate and position air dampers in HVAC systems.

- For air dampers up to approx. 0,5 m²
- Nominal voltage 24 Vac/dc and 230 Vac
- Control: 2-point, on-off and proportional
- Characteristics: universal spindle clamp for easy direct mounting, anti-rotation bracket provided for stability, selectable direction of rotation, adjustable angle of rotation, 1 m cable connection.



Technical features

Actuator model		SR3A	SR3AM	SR3B
Damper area	m ²		0,6	
Nominal torque	Nm		3	
Power supply	V	24 AC/DC	24 AC/DC	100...240 AC
Frequency	Hz		50/60	
Power consumption				
- in operation	W	5	2,5	5
- at rest	W	2	1,2	2
Running time for motor	s		<75	
Running time for spring	s		<25 (spring reset)	
Sound power level	db (A)	max 45 con motore, max 62 con ritorno a molla		
Control signal		2 punti, on-off	0...10 V DC	2 punti, on-off
Auxiliary switch rating		3(1.5) A, AC 230 V		
Life Cycle	cycles	70.000		
Rotation angle				
- operating		90° (95° meccanici)		
- limitation		5-85° (passi di 5°)		
Protection class		III	III	II
Protection degree		IP54		
Working range °C		-20...+50° C		
Working range RH		5...95% RH, senza condensa		
Storage temperature		-40...+70° C		
Maintenance		libera		
Maintenance	mm	> 90	> 50	> 90
Shaft length	mm	○ 10...16 □ 7x7...12x12		
Weight	g	1300	1500	1300
Standards		Conformità CE, RoHs		
Option		suffisso S per modelli con 2 interruttori ausiliari SPDT		



Electrical wirings

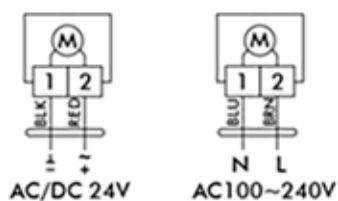

Auxiliary switches

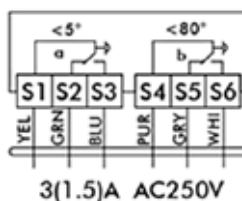

Settings

Limitation of rotation angle from 5° to 85°

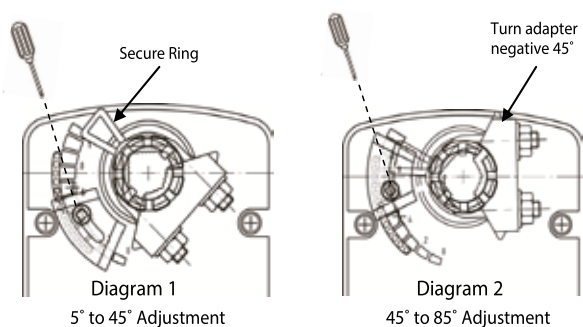

For 5° to 45° (diagram 1)

1. Loosen screw of the mechanical limiter plate.
2. Move the limiter plate to the appropriate position.
3. Tighten the screw.

For 45° to 85° (diagram 2)

1. Release the secure ring of the adapter.
2. Remove the adapter and turn negative 45° as shown.
3. Insert adapter and secure the adapter ring.
4. Loosen screw of the mechanical limiter plate.
5. Move the limiter plate to the appropriate position.
6. Tighten the screw.

Dimensions (mm)

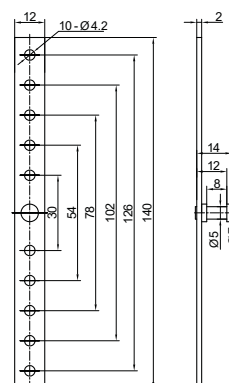
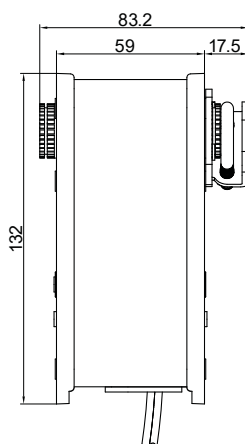
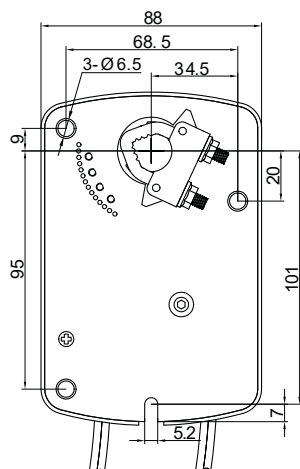
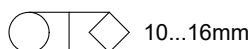

Spring-return damper actuator, 5 Nm

SR5

Description

Damper actuator serie SR5 to operate and position air dampers in HVAC systems.

- For air dampers up to approx. 1 m²
- Nominal voltage 24 Vac/dc and 230 Vac
- Control: 2-point, on-off and proportional
- Characteristics: universal spindle clamp fo easy direct mounting, anti-rotation bracket provided for stability, selectable direction of rotation, adjustable angle of rotation, 1 m cable connection.



Technical features

Actuator model		SR5A	SR5AM	SR5B
Damper area	m ²		0,5	
Nominal torque	Nm		5	
Power supply	V	24 AC/DC	24 AC/DC	100...240 AC
Frequency	Hz		50/60	
Power consumption				
- in operation	W	5.0	5.0	6.0
- at rest	W		2.5	
- for wire sizing	VA		7.0	
Running time for motor	s	<70	<120	<70
Running time for spring	s		<20 (spring reset)	
Sound power level	db (A)		< 45	
Control signal		2 point, on-off	0(2)...10 VDC / 0(4)...20 mA	2 point, on-off
Auxiliary switch rating			3 (1.5) A, AC 250 V	
Life Cycle	cycles		70.000	
Rotation angle				
- operating			90° (95° mechanical)	
- limitation			5-85° (steps of 5°)	
Protection class		III	III	II
Protection degree			IP54	
Working range °C			-20...+50° C	
Working range RH			5...95% RH, non-condensating	
Storage temperature			-40...+70° C	
Manual override		by means of hand crank and locking switch		
Maintenance		free		
Shaft length	mm		> 90	
Shaft diameter	mm		○ 10...16 □ 7...11	
Weight	g	1800	1800	1900
Standards		CE-conformity, RoHs		
Option		suffix S for models with 2 SPDT auxiliary switches		



Electrical wirings

Wiring diagram On/Off

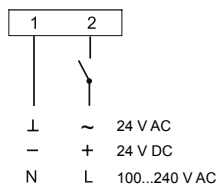

Wiring diagram proportional

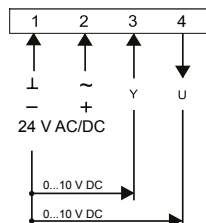

Auxiliary switches

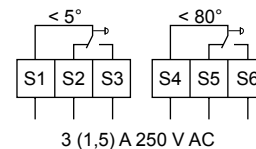

Settings

Limitation of rotation angle from 5° to 85°

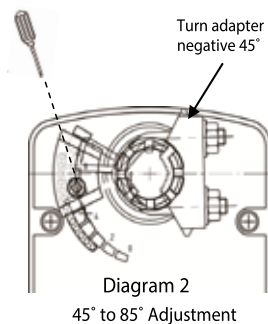
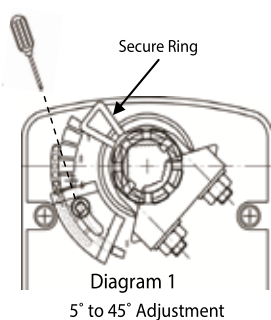

For 5° to 45° (diagram 1)

1. Loosen screw of the mechanical limiter plate.
2. Move the limiter plate to the appropriate position.
3. Tighten the screw.

For 45° to 85° (diagram 2)

1. Release the secure ring of the adapter.
2. Remove the adapter and turn negative 45° as shown.
3. Insert adapter and secure the adapter ring.
4. Loosen screw of the mechanical limiter plate.
5. Move the limiter plate to the appropriate position.
6. Tighten the screw.

Manual override: By using the hand crank the damper can be actuated manually and engaged with the locking switch at any position. Unlocking is carried out manually or automatically by applying the operating voltage.

Dimensions (mm)

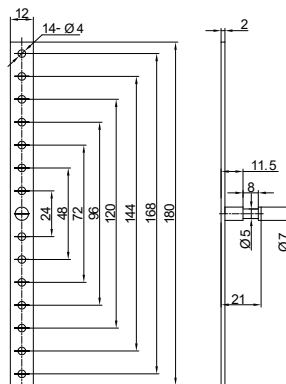
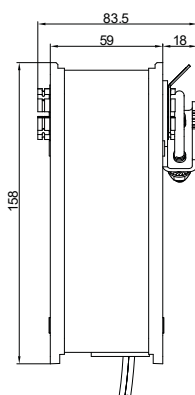
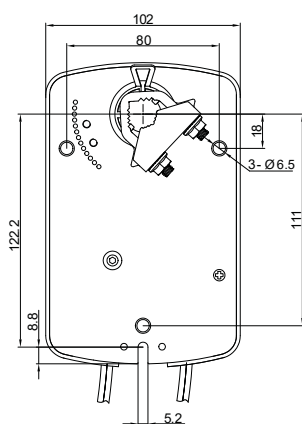
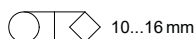

SR10

Spring-return damper actuator, 10 Nm



Description

Damper actuator serie SR10 to operate and position air dampers in HVAC systems.

- For air dampers up to approx. 2 m²
- Nominal voltage 24 Vac/dc and 230 Vac
- Control: 2-point, on-off and proportional
- Characteristics: universal spindle clamp for easy direct mounting, anti-rotation bracket provided for stability, selectable direction of rotation, adjustable angle of rotation, 1 m cable connection.

Technical features

Actuator model		SR10A	SR10AM	SR10B
Damper area	m ²		1,5	
Nominal torque	Nm		10	
Power supply	V	24 AC/DC	24 AC/DC	100...240 AC
Frequency	Hz		50/60	
Power consumption				
- in operation	W	5.0	5.0	6.5
- at rest	W		2.5	
- for wire sizing	VA		10.0	
Running time for motor	s	<100	<120	<100
Running time for spring	s		<25	
Sound power level	db (A)		50 (motor), 62 (spring)	
Control signal		2 point, on-off	0(2)...10 VDC / 0(4)...20 mA	2 point, on-off
Auxiliary switch rating			3 (1,5) A, AC 250 V	
Life Cycle	cycles		70.000	
Rotation angle				
- operating			0-90°	
- limitation			5-85° (steps of 5°)	
Protection class		III	III	II
Protection degree			IP54	
Working range °C			-20...+50° C	
Working range RH			5...95% RH, non-condensating	
Storage temperature			-40...+70° C	
Manual override		by means of hand crank and locking switch (only ON-OFF models)		
Maintenance			free	
Shaft length	mm		> 90	
Shaft diameter	mm		○ 10...21 □ 8x8...15x15	
Weight	g	2300	3000	2300
Standards			CE-conformity, RoHs	
Option		suffix S for models with 2 SPDT auxiliary switches		



Electrical wirings

Wiring diagram, On-Off

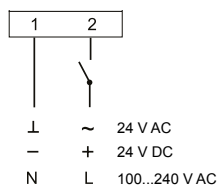

Wiring diagram, Proportional

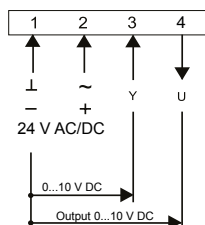

Auxiliary switches

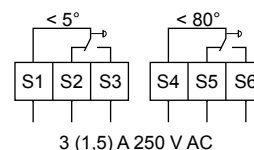

Settings

Limitation of rotation angle from 5° to 85°

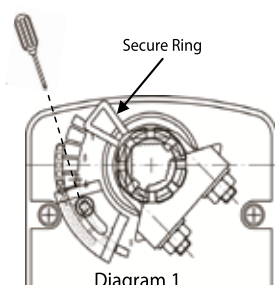

5° to 45° Adjustment

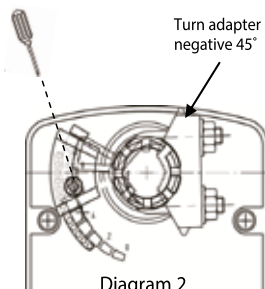

45° to 85° Adjustment

For 5° to 45° (diagram 1)

1. Loosen screw of the mechanical limiter plate.
2. Move the limiter plate to the appropriate position.
3. Tighten the screw.

For 45° to 85° (diagram 2)

1. Release the secure ring of the adapter.
2. Remove the adapter and turn negative 45° as shown.
3. Insert adapter and secure the adapter ring.
4. Loosen screw of the mechanical limiter plate.
5. Move the limiter plate to the appropriate position.
6. Tighten the screw.

Manual override: By using the hand crank the damper can be actuated manually and engaged with the locking switch at any position. Unlocking is carried out manually or automatically by applying the operating voltage.

Dimensions (mm)

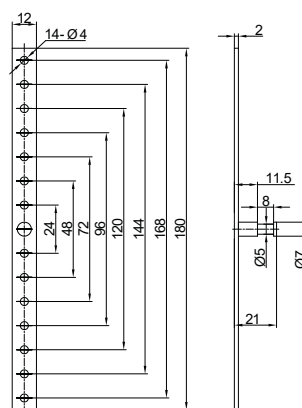
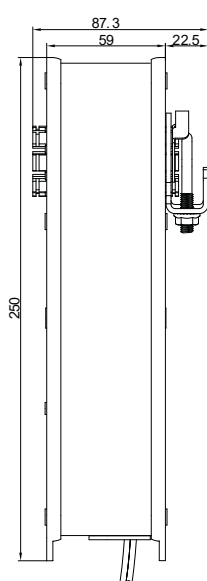
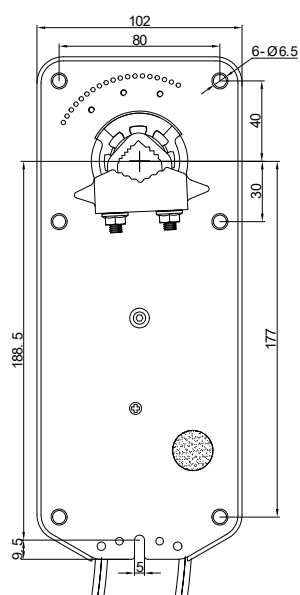
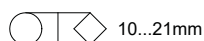

SR15

Spring-return damper actuator, 15 Nm



Description

Damper actuator serie SR15 to operate and position air dampers in HVAC systems.

- For air dampers up to approx. 3 m²
- Nominal voltage 24 Vac/dc and 230 Vac
- Control: 2-point, on-off and proportional
- Characteristics: universal spindle clamp for easy direct mounting, anti-rotation bracket provided for stability, selectable direction of rotation, adjustable angle of rotation, 1 m cable connection.

Technical features

Actuator model		SR15A	SR15AM	SR15B
Damper area	m ²		3	
Nominal torque	Nm		15	
Power supply	V	24 AC/DC	24 AC/DC	240 AC
Frequency	Hz		50/60	
Power consumption				
- in operation	W	6,5	6,5	7,0
- at rest	W		3,0	
- for wire sizing	VA		10,0	
Running time for motor	s	<150	<120	<150
Running time for spring	s		25 (spring reset)	
Sound power level	db (A)		50 (motor), 62 (spring)	
Control signal		2 point, on-off	0(2)...10 VDC / 0(4)...20 mA	2 point, on-off
Auxiliary switch rating			3 (1,5) A, AC 250 V	
Life Cycle	cicli		70.000	
Rotation angle				
- operating			0-90°	
- limitation			5-85° (steps of 5°)	
Protection class		III	III	II
Protection degree			IP54	
Working range °C			-20...+50° C	
Working range RH			5...95% RH, non-condensating	
Storage temperature			-40...+70° C	
Manual override		by means of hand crank and locking switch (only ON-OFF models)		
Maintenance		free		
Shaft length	mm		> 90	
Shaft diameter	mm		○ 10...21 □ 8x8...15x15	
Weight	g	2600	3000	2600
Standards		CE-conformity, RoHs		
Option		suffix S for models with 2 SPDT auxiliary switches		



Electrical wirings

Wiring diagram, On-Off

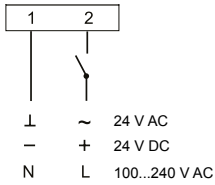

Wiring diagram, Proportional

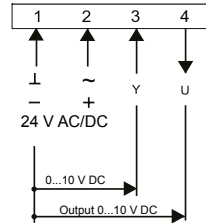

Auxiliary switches

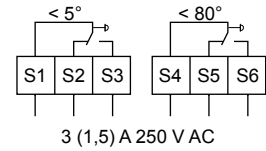

Settings

Limitation of rotation angle from 5° to 85°

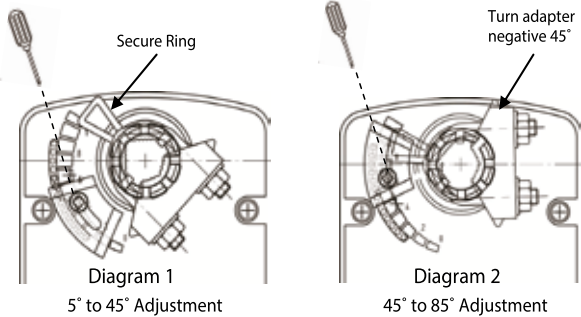

For 5° to 45° (diagram 1)

1. Loosen screw of the mechanical limiter plate.
2. Move the limiter plate to the appropriate position.
3. Tighten the screw.

For 45° to 85° (diagram 2)

1. Release the secure ring of the adapter.
2. Remove the adapter and turn negative 45° as shown.
3. Insert adapter and secure the adapter ring.
4. Loosen screw of the mechanical limiter plate.
5. Move the limiter plate to the appropriate position.
6. Tighten the screw.

Manual override: By using the hand crank the damper can be actuated manually and engaged with the locking switch at any position. Unlocking is carried out manually or automatically by applying the operating voltage.

Dimensions (mm)

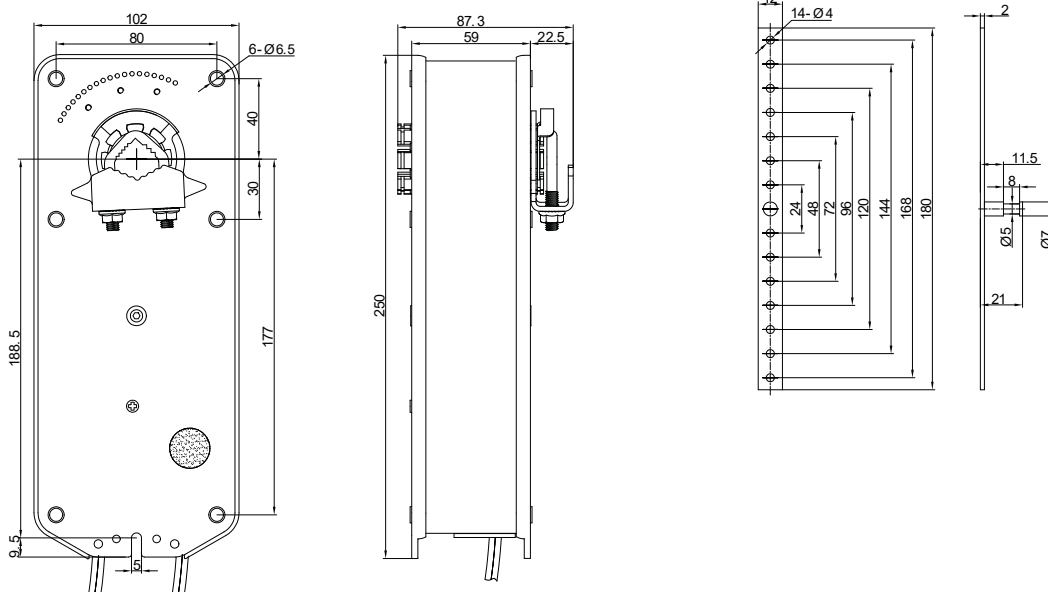
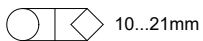

SR20

Spring-return damper actuator, 20 Nm



Description

Damper actuator serie SR20 to operate and position air dampers in HVAC systems.

- For air dampers up to approx. 4 m²
- Nominal voltage 24 Vac/dc and 230 Vac
- Control: 2-point, on-off and proportional
- Characteristics: universal spindle clamp fo easy direct mounting, anti-rotation bracket provided for stability, selectable direction of rotation, adjustable angle of rotation, 1 m cable connection.

Technical features

Actuator model		SR20A	SR20AM	SR20B
Damper area	m ²		4	
Nominal torque	Nm		20	
Power supply	V	24 AC/DC	24 AC/DC	240 AC
Frequency	Hz		50/60	
Power consumption				
- in operation	W	6,5	6,5	7,0
- at rest	W		3,0	
- for wire sizing	VA		10,0	
Running time for motor	s		<180	
Running time for spring	s		<30 (spring reset)	
Sound power level	db (A)		50 (motor), 62 (spring)	
Control signal		2 point, on-off	0(2)...10 VDC / 0(4)...20 mA	2 point, on-off
Auxiliary switch rating			3 (1,5) A, AC 250 V	
Life Cycle	cicli		70.000	
Rotation angle				
- operating			0-90°	
- limitation			5-85° (steps of 5°)	
Protection class		III	III	II
Protection degree			IP54	
Working range °C			-20...+50° C	
Working range RH			5...95% RH, non-condensating	
Storage temperature			-40...+70° C	
Manual override		by means of hand crank and locking switch (only ON-OFF models)		
Maintenance			free	
Shaft length	mm		> 90	
Shaft diameter	mm		○ 10...21 □ 8x8...15x15	
Weight	g		2700	
Standards		CE-conformity, RoHs		
Option		suffix S for models with 2 SPDT auxiliary switches		



Electrical wirings

Wiring diagram, On-Off

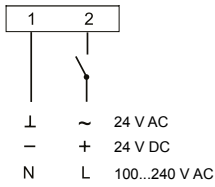

Wiring diagram, Proportional

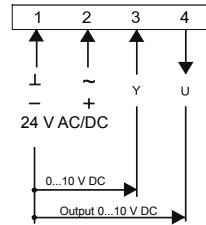

Auxiliary switches

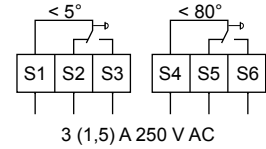

Settings

Limitation of rotation angle from 5° to 85°

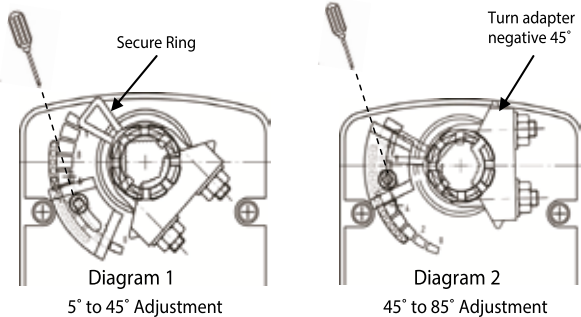

For 5° to 45° (diagram 1)

1. Loosen screw of the mechanical limiter plate.
2. Move the limiter plate to the appropriate position.
3. Tighten the screw.

For 45° to 85° (diagram 2)

1. Release the secure ring of the adapter.
2. Remove the adapter and turn negative 45° as shown.
3. Insert adapter and secure the adapter ring.
4. Loosen screw of the mechanical limiter plate.
5. Move the limiter plate to the appropriate position.
6. Tighten the screw.

Manual override: By using the hand crank the damper can be actuated manually and engaged with the locking switch at any position. Unlocking is carried out manually or automatically by applying the operating voltage.

Dimensions (mm)

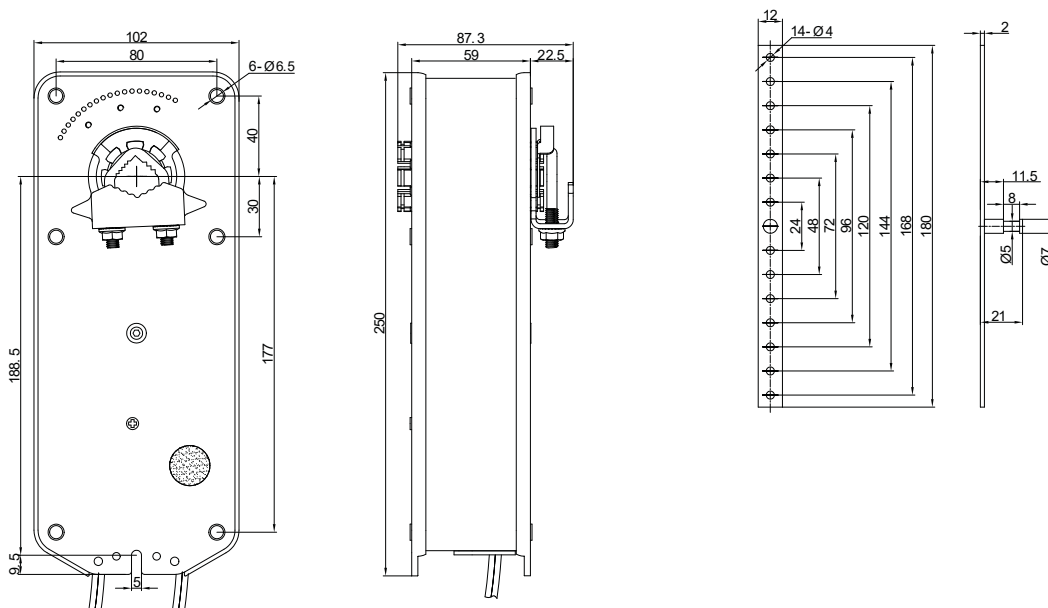
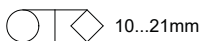

Description

Damper actuator serie ST3 to operate and position air dampers in HVAC systems.

- For air dampers up to approx. 0,6 m²
- Nominal voltage 24 V AC/DC and 100...240 V AC
- Control: 2-point, on-off
- Characteristics: shaft dimensions standard □12/12 mm square, minimum shaft length 90 mm, anti-rotation bracket provided for stability, selectable direction of rotation, 2 not adjustable SPDT auxiliary switches, 1 m cable connection, thermal duct sensor included.



Technical features

Actuator model		ST3AT	ST3BT
Damper area	m ²		0,6
Nominal torque	Nm		3
Power supply	V	24 AC/DC	100...240 AC
Frequency	Hz		50/60
Power consumption			
- in operation	W		5
- at rest	W		3
- for wire sizing	VA		7,0
Running time for motor	s		<75
Running time for spring	s		< 25
Sound power level	db (A)		45
Control signal			2 point, on-off
Auxiliary switch rating			3 (1,5) A, AC 230 V
Life cycle	cycles		60.000
Rotation angle			
- operating			90° (95° mechanical)
- limitation			5-85° (steps of 5°)
Thermal temperature trip			> 72°
Protection class		III	II
Protection degree			IP54
Working temperature °C			-20...+50° C
Working humidity RH			5...95% RH, non-condensating
Storage temperature			-30...+80° C
Maintenance			free
Weight	g		<1300
Standards			CE-conformity, RoHs



Electrical wirings

Wiring diagram

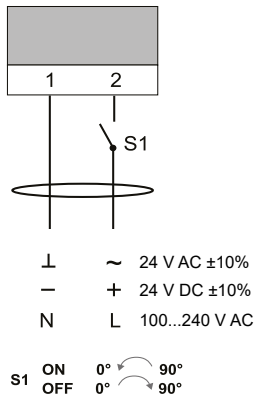

Auxiliary switches

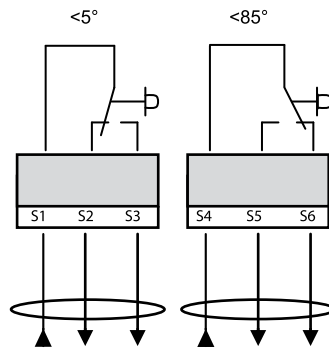

Thermal sensor

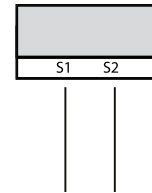

Setting

Manual override

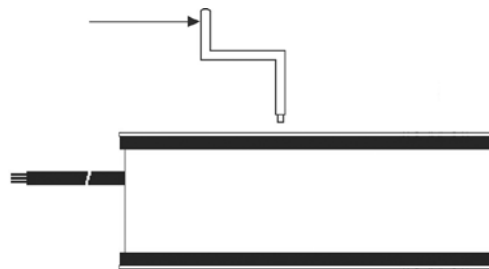

Dimensions (mm)

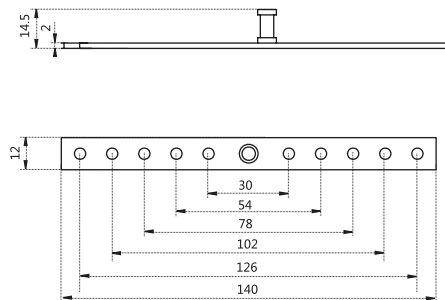
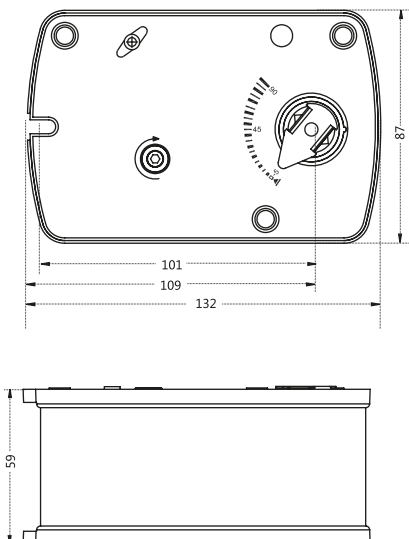

Thermal sensor

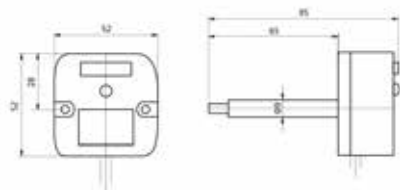

The thermal sensor controls the temperature in two areas: room and duct. The damper actuator will open when the temperature reaches 72°C in one of the two zones. There is a test button on the sensor.

Description

Damper actuator serie ST5 to operate and position air dampers in HVAC systems.

- For air dampers up to approx. 1 m²
- Nominal voltage 24 V AC/DC and 100...240 V AC
- Control: 2-point, on-off
- Characteristics: shaft dimensions standard □12/12 mm square, minimum shaft length 90 mm, anti-rotation bracket provided for stability, selectable direction of rotation, 2 not adjustable SPDT auxiliary switches, 1 m cable connection, thermal duct sensor included.



Technical features

Actuator model		ST5AT	ST5BT
Damper area	m ²		1
Nominal torque	Nm		5
Power supply	V	24 AC/DC	100...240 AC
Frequency	Hz		50/60
Power consumption			
- in operation	W		5
- at rest	W		3
- for wire sizing	VA		7,0
Running time for motor	s		<70
Running time for spring	s		< 20
Sound power level	db (A)		45
Control signal			2 point, on-off
Auxiliary switch rating			3 (1,5) A, AC 230 V
Life cycle	cycles		60.000
Rotation angle			
- operating			90° (95° mechanical)
- limitation			5-85° (steps of 5°)
Thermal temperature trip			> 72°
Protection class		III	II
Protection degree			IP54
Working temperature °C			-20...+50° C
Working humidity RH			5...95% RH, non-condensating
Storage temperature			-30...+80° C
Maintenance			free
Weight	g		<2000
Standards			CE-conformity, RoHs

Fire and smoke spring return damper actuator, 10 Nm

ST10

Description

Damper actuator serie ST10 to operate and position air dampers in HVAC systems.

- For air dampers up to approx. 1,5 m²
- Nominal voltage 24 V AC/DC and 100...240 V AC
- Control: 2-point, on-off
- Characteristics: shaft dimensions □12/12 mm square, minimum shaft length 90 mm, anti-rotation bracket provided for stability, selectable direction of rotation, 2 not adjustable SPDT auxiliary switches, 1 m cable connection, thermal duct sensor included.



Technical features

Actuator model		ST10AT	ST10BT
Damper area	m ²		1,5
Nominal torque	Nm		10
Power supply	V	24 AC/DC	100...240 AC
Frequency	Hz		50/60
Power consumption			
- in operation	W		5
- at rest	W		3
- for wire sizing	VA		7,0
Running time for motor	s	<100	75...95
Running time for spring	s		< 25
Sound power level	db (A)		45
Control signal			2 point, on-off
Auxiliary switch rating			3 (1,5) A, AC 230 V
Life cycle	cycles		60.000
Rotation angle			
- operating			90° (95° mechanical)
- limitation			5-85° (steps of 5°)
Thermal temperature trip			> 72°
Protection class		III	II
Protection degree			IP54
Working temperature °C			-20...+50° C
Working humidity RH			5...95% RH, non-condensating
Storage temperature range			-30...+80° C
Maintenance			free
Weight	g		<2300
Standards			CE-conformity, RoHs



Electrical wirings

Wiring diagram

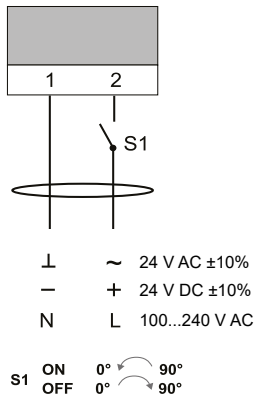

Auxiliary switches

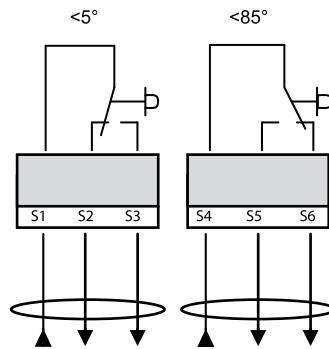

Thermal sensor

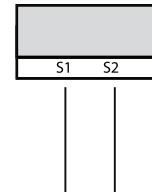

Setting

Manual override

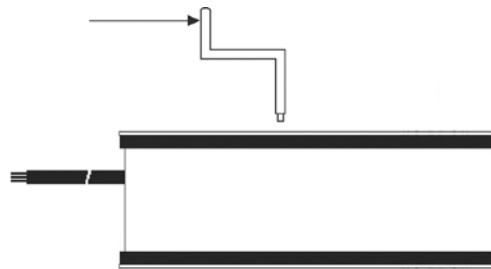

Dimensions (mm)

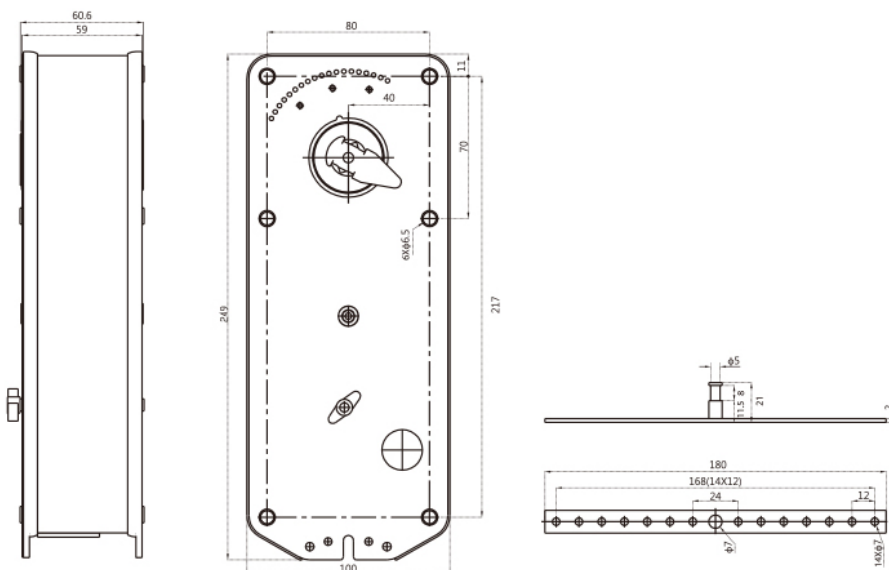

Thermal sensor

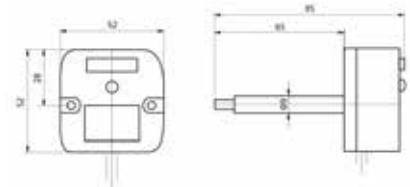

The thermal sensor controls the temperature in two areas: room and duct. The damper actuator will open when the temperature reaches 72°C in one of the two zones. There is a test button on the sensor.

Description

Damper actuator serie ST15 to operate and position air dampers in HVAC systems.

- For air dampers up to approx. 3 m²
- Nominal voltage 24 V AC/DC and 100...240 V AC
- Control: 2-point, on-off
- Characteristics: shaft dimensions □12/12 mm square, minimum shaft length 90 mm, anti-rotation bracket provided for stability, selectable direction of rotation, 2 not adjustable SPDT auxiliary switches, 1 m cable connection, thermal duct sensor included.



Technical features

Actuator model		ST15AT	ST15BT
Damper area	m ²		3
Nominal torque	Nm		15
Power supply	V	24 AC/DC	100...240 AC
Frequency	Hz		50/60
Power consumption			
- in operation	W		8
- at rest	W		2,5
- for wire sizing	VA		7,0
Running time for motor	s		<150
Running time for spring	s		< 25
Sound power level	db (A)		45
Control signal			2 point, on-off
Auxiliary switch rating			3 (1,5) A, AC 230 V
Life cycle	cycles		60.000
Rotation angle			
- operating			90° (95° mechanical)
- limitation			5-85° (steps of 5°)
Thermal temperature trip			> 72°
Protection class		III	II
Protection degree			IP54
Working temperature °C			-20...+50° C
Working humidity RH			5...95% RH, non-condensating
Storage temperature range			-30...+80° C
Maintenance			free
Weight	g		<2600
Standards			CE-conformity, RoHs



Electrical wirings

Wiring diagram

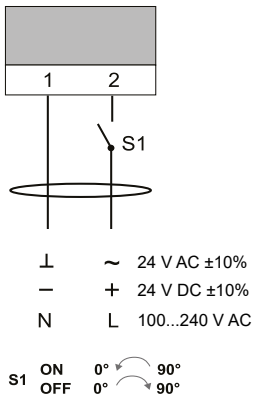

Auxiliary switches

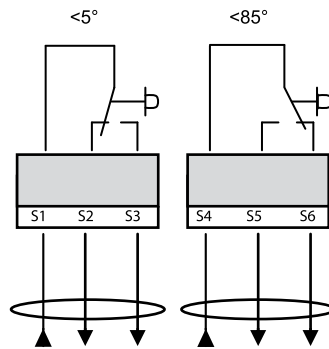

Thermal sensor

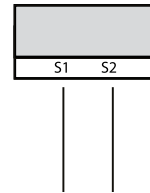

Setting

Manual override

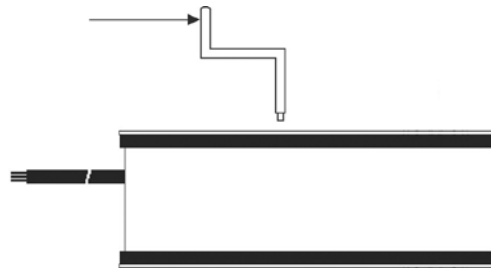

Dimensions (mm)

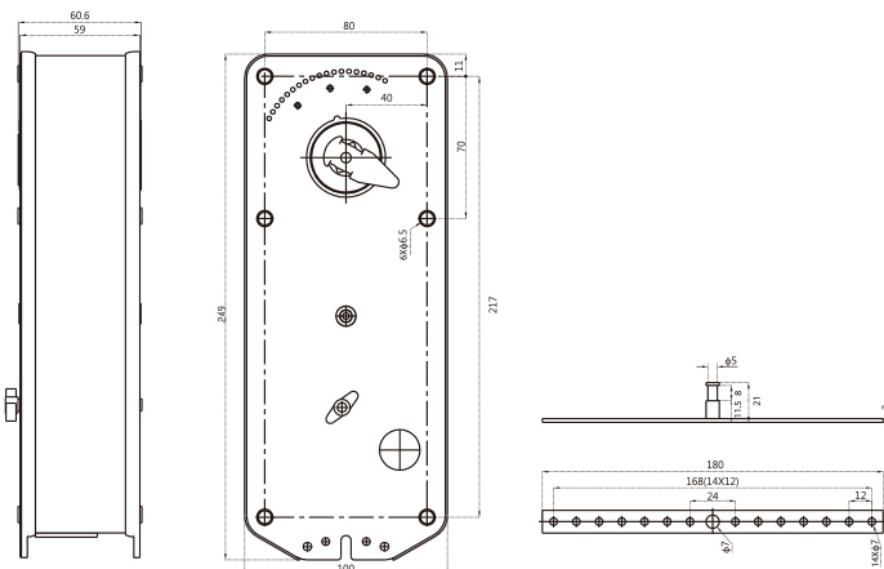

Thermal sensor

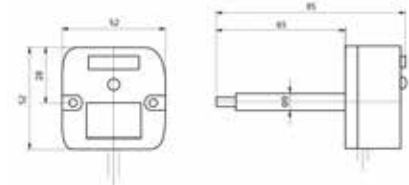

The thermal sensor controls the temperature in two areas: room and duct. The damper actuator will open when the temperature reaches 72°C in one of the two zones. There is a test button on the sensor.

Fire and smoke spring return damper actuator, 20 Nm

ST20

Description

Damper actuator serie ST20 to operate and position air dampers in HVAC systems.

- For air dampers up to approx. 4 m²
- Nominal voltage 24 V AC/DC and 100...240 V AC
- Control: 2-point, on-off
- Characteristics: shaft dimensions □12/12 mm square, minimum shaft length 90 mm, anti-rotation bracket provided for stability, selectable direction of rotation, 2 not adjustable SPDT auxiliary switches, 1 m cable connection, thermal duct sensor included.



Technical features

Actuator model		ST20AT	ST20BT
Damper area	m ²		4
Nominal torque	Nm		20
Power supply	V	24 AC/DC	100...240 AC
Frequency	Hz		50/60
Power consumption			
- in operation	W		8
- at rest	W		2,5
- for wire sizing	VA		7,0
Running time for motor	s		<180
Running time for spring	s		< 30
Sound power level	db (A)		<45
Control signal			2 point, on-off
Auxiliary switch rating			3 (1,5) A, AC 230 V
Life cycle	cycles		60.000
Rotation angle			
- operating			90° (95° mechanical)
- limitation			5-85° (steps of 5°)
Thermal temperature trip			> 72°
Protection class		III	II
Protection degree			IP54
Working temperature °C			-20...+50° C
Working humidity RH			5...95% RH, non-condensating
Storage temperature range			-30...+80° C
Maintenance			free
Weight	g		<2600
Standards			CE-conformity, RoHs



Electrical wirings

Wiring diagram

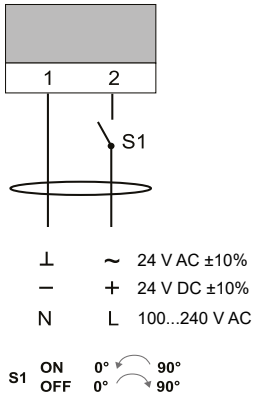

Auxiliary switches

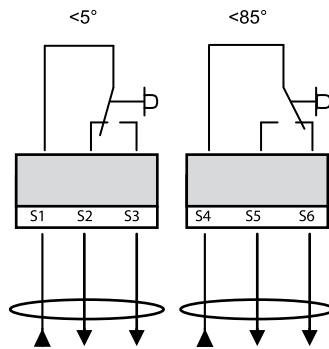

Thermal sensor

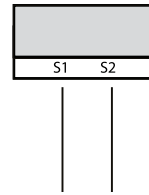

Setting

Manual override

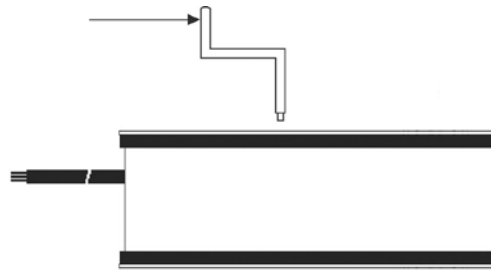

Dimensions (mm)

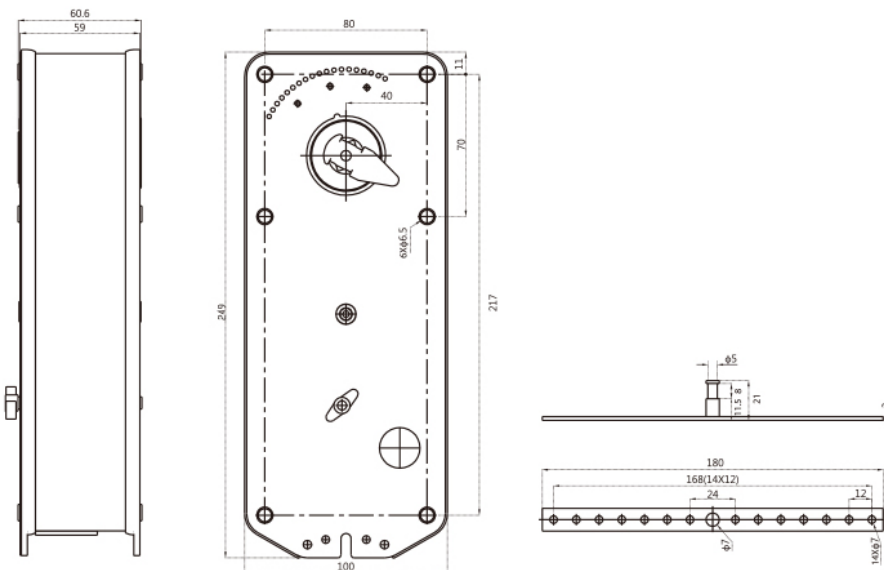

Thermal sensor

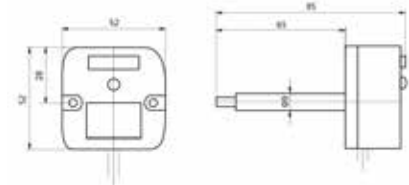

The thermal sensor controls the temperature in two areas: room and duct. The damper actuator will open when the temperature reaches 72°C in one of the two zones. There is a test button on the sensor.

Description

Damper actuator serie SF10 to operate and position air dampers in HVAC systems.

- For air dampers up to approx. 1,5 m²
- Nominal voltage 24 V AC/DC and 100...240 V AC
- Control: 2 and 3-point
- Characteristics: shaft dimensions standard □12/12 mm square, minimum shaft length 90 mm, anti-rotation bracket provided for stability, selectable direction of rotation, 2 not adjustable SPDT auxiliary switches, 1 m cable connection.



Technical features

Actuator model		SF10A	SF10B
Damper area	m ²		1,5
Nominal torque	Nm		10
Power supply	V	24 AC/DC	100...240 AC
Frequency	Hz		50/60
Power consumption			
- in operation	W		5
- at rest	W		0,5
- for wire sizing	VA		7,0
Running time	s		<45
Sound power level	db (A)		45
Control signal			2 and 3 point
Auxiliary switch rating			3 (1,5) A, AC 230 V
Life cycle	cycles		60.000
Rotation angle			
- operating			90° (95° mechanical)
- limitation			5-85° (steps of 5°)
Protection class		III	II
Protection degree			IP54
Working temperature °C			-20...+50° C
Working humidity RH			5...95% RH, non-condensating
Storage temperature			-30...+80° C
Maintenance			free
Weight	g		<1800
Standards			CE-conformity, RoHs



Electrical wirings

Wiring diagram

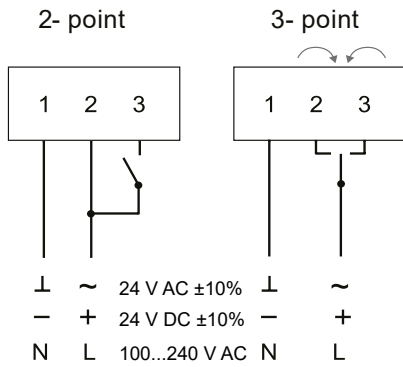

Auxiliary switches

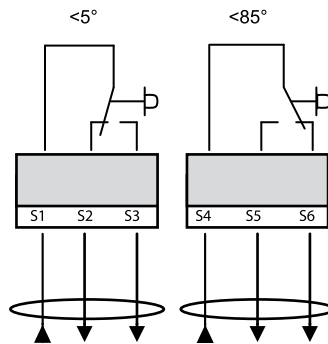

Setting

Manual override

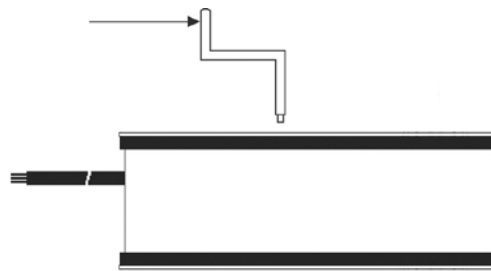

Dimensions (mm)

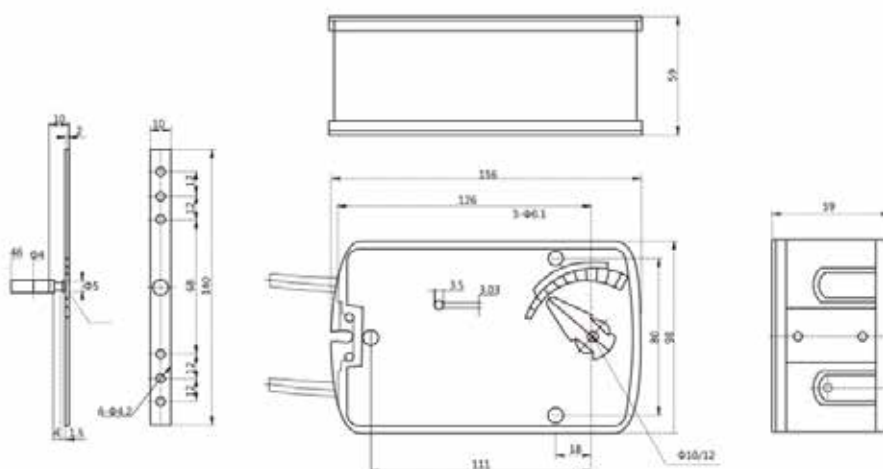

Smoke control damper actuator, 15 Nm

SF15

Description

Damper actuator serie SF15 to operate and position air dampers in HVAC systems.

- For air dampers up to approx. 2 m²
- Nominal voltage 24 V AC/DC and 100...240 V AC
- Control: 2 and 3-point
- Characteristics: shaft dimensions standard □12/12 mm square, minimum shaft length 90 mm, anti-rotation bracket provided for stability, selectable direction of rotation, 2 not adjustable SPDT auxiliary switches, 1 m cable connection.



Technical features

Actuator model		SF15A	SF15B
Damper area	m ²		2
Nominal torque	Nm		15
Power supply	V	24 AC/DC	100...240 AC
Frequency	Hz		50/60
Power consumption			
- in operation	W		5
- at rest	W		0,5
- for wire sizing	VA		7,0
Running time	s		<30
Sound power level	db (A)		45
Control signal			2 and 3 point
Auxiliary switch rating			3 (1,5) A, AC 230 V
Life cycle	cycles		60.000
Rotation angle			
- operating			90° (95° mechanical)
- limitation			5-85° (steps of 5°)
Protection class		III	II
Protection degree			IP54
Working temperature °C			-20...+50° C
Working humidity RH			5...95% RH, non-condensating
Storage temperature			-30...+80° C
Maintenance			free
Weight	g		<1800
Standards			CE-conformity, RoHs



Description

Damper actuator serie SF30 to operate and position air dampers in HVAC systems.

- For air dampers up to approx. 4 m²
- Nominal voltage 24 V AC/DC and 100...240 V AC
- Control: 2 and 3-point
- Characteristics: shaft dimensions standard □12/12 mm square, minimum shaft length 90 mm, anti-rotation bracket provided for stability, selectable direction of rotation, 2 not adjustable SPDT auxiliary switches, 1 m cable connection.



Technical features

Actuator model		SF30A	SF30B
Damper area	m ²		4
Nominal torque	Nm		30
Power supply	V	24 AC/DC	100...240 AC
Frequency	Hz		50/60
Power consumption			
- in operation	W	7	8
- at rest	W	2.0	2.5
- for wire sizing	VA		8.0
Running time	s		115
Sound power level	db (A)		<45
Control signal			2 and 3 point
Auxiliary switch rating			3 (1,5) A, AC 230 V
Life cycle	cycles		60.000
Rotation angle			
- operating			90° (95° mechanical)
- limitation			5-85° (steps of 5°)
Protection class		III	II
Protection degree			IP54
Working temperature °C			-20...+50° C
Working humidity RH			5...95% RH, non-condensating
Storage temperature			-30...+80° C
Maintenance			free
Weight	g		<2200
Standards			CE-conformity, RoHs



Electrical wirings

Wiring diagram

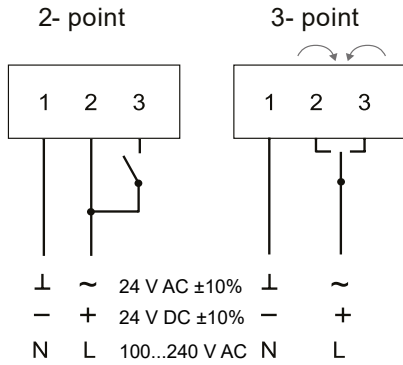

Auxiliary switches

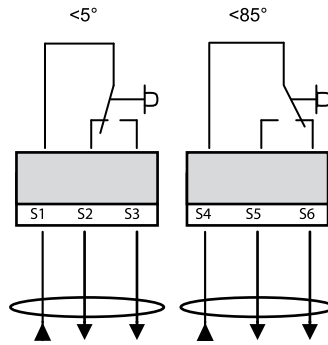

Setting

Manual override

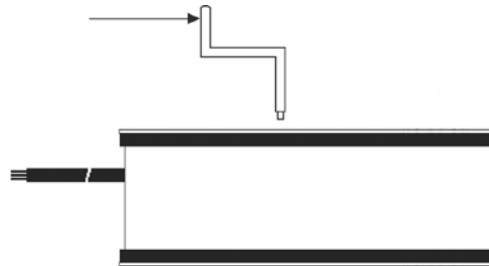

Dimensions (mm)

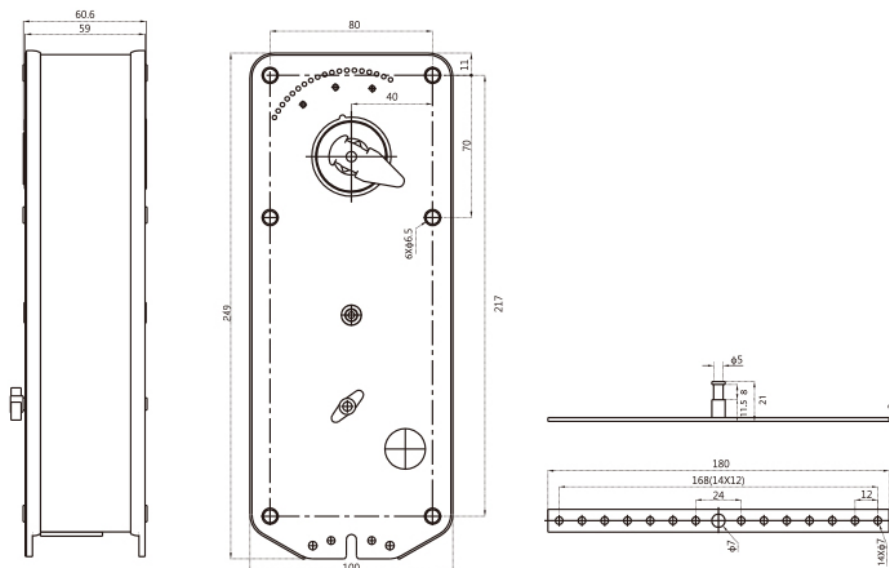

Damper actuator, ATEX version

SX

Description

Damper actuator SX serie to operate and position air dampers in HVAC systems.

- For air dampers up to approx. 3 m² up to 9 m²
- Nominal voltage 24 Vac/dc and 230 Vac
- Control: 3-point
- Characteristics: universal spindle clamp for easy direct mounting, shaft diameter 10x10 mm / 12x12 mm, minimum shaft length 80 mm, anti-rotation bracket provided for stability, selectable direction of rotation, adjustable angle of rotation, 1 m cable connection.



Technical features

Actuator model		SX10A	SX10B	SX20A	SX20B	SX30A	SX30B
Damper area	m ²		2		4		6
Nominal torque	Nm		10		20		30
Power supply	V	24 AC/DC	230 V AC	24 AC/DC	230 V AC	24 AC/DC	230 V AC
Frequency	Hz				50/60		
Power consumption							
- in operation	W		7		10		12
- at rest	W				3		
Running time	s				≤ 90		
Sound power level	db (A)				50		
Control signal					3 points, on-off		
Auxiliary switch rating					3 (1,5) A, AC 250 V		
Life Cycle	cycles				≥ 10.000		
Rotation angle					Max 93°		
Protection class		III	II	III	II	III	II
Protection degree					IP66		
Working range °C					-20...+60° C		
Working range RH					5...95% RH, non-condensating		
Storage temperature					-40...+70° C		
Maintenance					free		
Standards					Conformità CE, RoHs, ATEX 2014/34/UE		
ATEX					Ex d II B T6 Gb Ex IIIC T85°C Db		
Application					Zone 1 and zone 2, zone 21 and zone 22		

Directives:

IEC60079-0:2011, EN60079-0:2012 electrical apparatus in explosive gas atmosphere General requirements.
IEC60079-1:2007, EN60079-1:2007 electrical apparatus in explosive gas atmosphere part1: flameproof " d ".
IEC60079-31:2008, EN60079-31:2009 Equipment dust ignition protection by enclosure " t " .



Electrical wirings

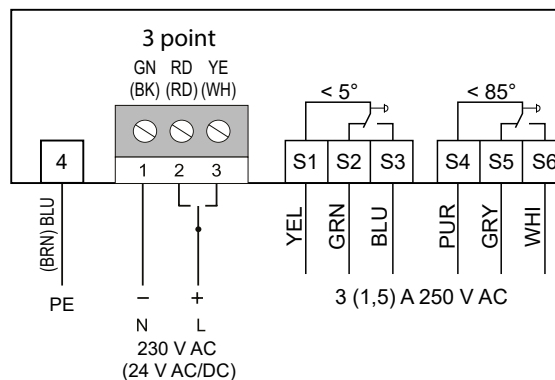

Use and maintenance

- Cable gland and thread on the M16 × 1.5 housing, cable diameter from 6 to 8 mm. When the actuator is installed on site, the cable gland must be installed by the user and whose degree of protection must not be less than II2D Ex tb IIIC T85 ° C Db.
- Earth terminal tightening torque 2 Nm.
- Tightening torque of the flameproof joint 3,2 Nm.
- External ground bolt M4x6, by pressing the 4 mm² conductor.
- Disassembly is prohibited without authorization. Do not open with the power on. Do not open the lid in the presence of explosive gas. Use a damp cloth when opening.
- Repair of flanged joints must be performed in accordance with the structural specifications provided by the manufacturer. Repairs must not be carried out on the basis of the specifications in table 3 and table 4 of the EN 60079-1: 2007 directive.
- The cable gland must have a degree of protection compatible with the intended use.
- During assembly, operation and maintenance, the operator must follow the requirements of the EN 60079-14 standard and this instruction manual.
- Repair and overhaul must comply with EN 60079-19.

Dimensions (mm)

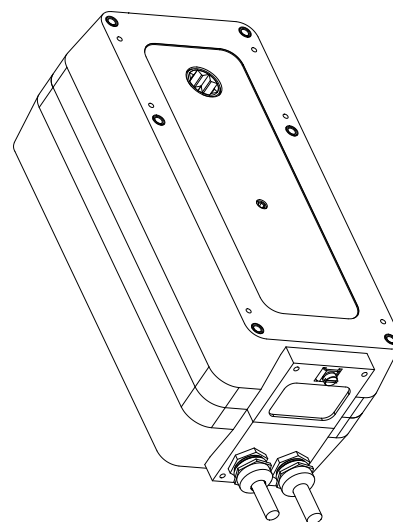
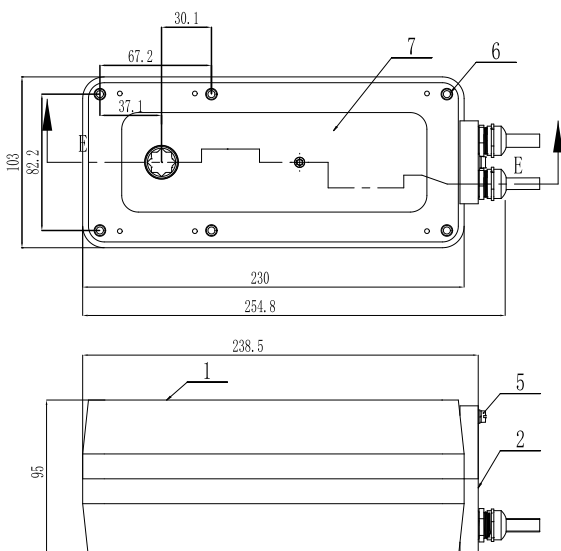

Description

Damper actuator SRX serie to operate and position air dampers in HVAC systems.

- For air dampers up to approx. 1 m² up to 4,5 m²
- Nominal voltage 24 Vac/dc and 230 Vac
- Control: 2-point with spring return
- Characteristics: universal spindle clamp for easy direct mounting, shaft diameter 10x10 mm / 12x12 mm, minimum shaft length 80 mm, anti-rotation bracket provided for stability, selectable direction of rotation, adjustable angle of rotation, 1 m cable connection.



Technical features

Actuator model		SRX5A	SRX5B	SRX10A	SRX10B	SRX15A	SRX15B
Damper area	m ²		1		2		3
Nominal torque	Nm		5		10		15
Power supply	V	24 AC/DC	230 V AC	24 AC/DC	230 V AC	24 AC/DC	230 V AC
Frequency	Hz				50/60		
Power consumption							
- in operation	W				7		
- at rest	W				3		
Running time for motor	s				< 150		
Running time for spring	s				< 30		
Sound power level	db (A)				50...62		
Control signal					2 points, on-off		
Auxiliary switch rating					3 (1,5) A, AC 250 V		
Life Cycle	cycles				≥ 10.000		
Rotation angle					Max 93°		
Protection class		III	II	III	II	III	II
Protection degree					IP66		
Working range °C					-20...+60° C		
Working range RH					5...95% RH, non-condensating		
Storage temperature					-40...+70° C		
Maintenance					free		
Standards					Conformità CE, RoHs, ATEX 2014/34/UE		
ATEX					Ex d II B T6 Gb Ex IIIC T85°C Db		
Application					Zone 1 and zone 2, zone 21 and zone 22		

Directives:

IEC60079-0:2011, EN60079-0:2012 electrical apparatus in explosive gas atmosphere General requirements.
IEC60079-1:2007, EN60079-1:2007 electrical apparatus in explosive gas atmosphere part1: flameproof " d ".
IEC60079-31:2008, EN60079-31:2009 Equipment dust ignition protection by enclosure " t " .



Electrical wirings

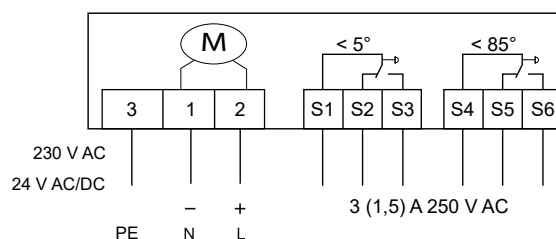

Use and maintenance

- Cable gland and thread on the M16 × 1.5 housing, cable diameter from 6 to 8 mm. When the actuator is installed on site, the cable gland must be installed by the user and whose degree of protection must not be less than II2D Ex tb IIIC T85 ° C Db.
- Earth terminal tightening torque 2 Nm.
- Tightening torque of the flameproof joint 3,2 Nm.
- External ground bolt M4x6, by pressing the 4 mm² conductor.
- Disassembly is prohibited without authorization. Do not open with the power on. Do not open the lid in the presence of explosive gas. Use a damp cloth when opening.
- Repair of flanged joints must be performed in accordance with the structural specifications provided by the manufacturer. Repairs must not be carried out on the basis of the specifications in table 3 and table 4 of the EN 60079-1: 2007 directive.
- The cable gland must have a degree of protection compatible with the intended use.
- During assembly, operation and maintenance, the operator must follow the requirements of the EN 60079-14 standard and this instruction manual.
- Repair and overhaul must comply with EN 60079-19.

Dimensions (mm)

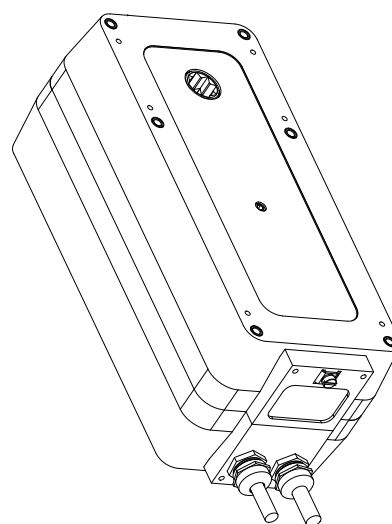
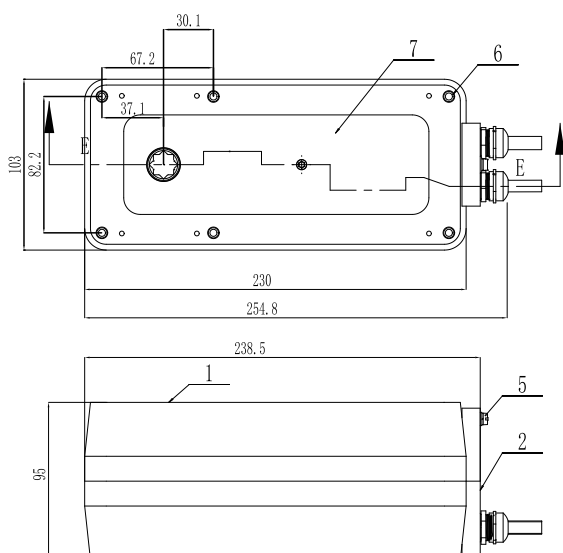



greenline

motorized valves



Description

The motorized valve serie VB are intercepting, diverting or mixing fluids in heating and cooling systems and are motorized by the electrothermal actuator serie SVB. The 2-way valves are used for opening and closing, while the 3-way and 4-way valves can be used as diverting or mixing valves. When the stem is pressed the valve is closed. The small sizes allow easy installation in fan coils and terminal unit coils. The actuator-valve assembly is easily made thanks to its threaded ring nut, which allows a comfortable cable positioning.

Technical specifications valve VB

Medium	Hot and chilled water, water with up to 50% glycol
Fluid temperature	+2...+120°C
Nominal pressure	16 bar
Stroke	3 mm
Leakage	Perfect sealing
Connection type	Male thread
Installation position	See drawing
Maintenance	Free
Valve body	Forged brass
Valve stem	Stainless steel Aisi 301
Sealing	HNBR
Dimensions and weights	See schedule



Models	Thread	Ways	KVs	Max differential pressure (bar)
VB215	G 1/2	2	1.6	2.5
VB220	G 3/4	2	2.5	2.5
VB225	G 1"	2	4,5	1.0
VB315	G 1/2	3	1.6	2.5
VB320	G 3/4	3	2.5	2.5
VB325	G 1"	3	4,5	1.0
VB415	G 1/2	3 (4 ports)	1.6	2.5
VB420	G 3/4	3 (4 ports)	2.5	2.5
VB425	G 1"	3 (4 ports)	4.5	1.0

Technical specifications actuator SVB

Power consumption	2,5 W (by starting)
Stroke	4 mm (4,5 mm proportional version)
Running time	approx. 5 min.
Connection	Metal ring M30 x 1.5
Materials	Self-extinguishing V0
Cable	PVC 2 x 0,50 mm ²
Protection degree	IP54
Protection class	II
Working range RH	0...95% RH, non-condensing
Working range °C	-5...+50°C
Storage temperature	-25...+60°C
Standards	CE-conformity, RoHS

VB, SVB



Models	Power supply	Action	Force	Contact rating
SVB230	230 V AC	2 punti / on/off	110 N	-
SVB230C	230 V AC	2 punti / on/off	110 N	Max 700 m A – 250 V AC
SVB24	24 V AC	2 punti / on/off	110 N	-
SVB24C	24 V AC	2 punti / on/off	110 N	Max 700 m A – 250 V AC
SVB24M	24 V AC	Modulante	170 N	-

Installation

Before mounting the valve body be sure that the pipes are clean, free of soldering scraps and that the plug can glide freely. Note direction of flow reported on the valve body.

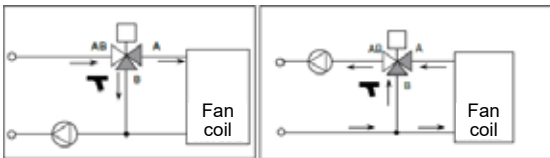

Valve type		close valve	open valve
	Mixing		
	Diverting		
	Mixing		
	Diverting		

▶ = flow
▷ = no flow

Wiring

2 points / on/off

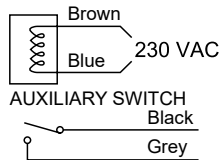

Proportional

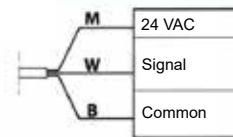

M = Brown (24 VAC - 50/60 Hz)
W = White (Signal 0-10 Vcc)
B = Blue (Common)

Indication



Stroke indicator

On the actuator there is a transparent window where the position of the valve stroke is indicated:

Red: Actuator off, direct way of valve close

Black: Actuator on, direct way of valve open

Dimensions (mm)

Models	Way	L	G	H	I	J
VB215	2	53	G 1/2		88	
VB220	2	56	G 3/4		88	
VB225	2	65	G 1		88	
VB315	3	53	G 1/2		88	30
VB320	3	56	G 3/4		88	30
VB325	3	65	G 1		90	35
VB415	3 (4 port)	53	G 1/2	40	88	
VB420	3 (4 port)	56	G 3/4	40	88	
VB425	3 (4 port)	65	G 1	50	90	

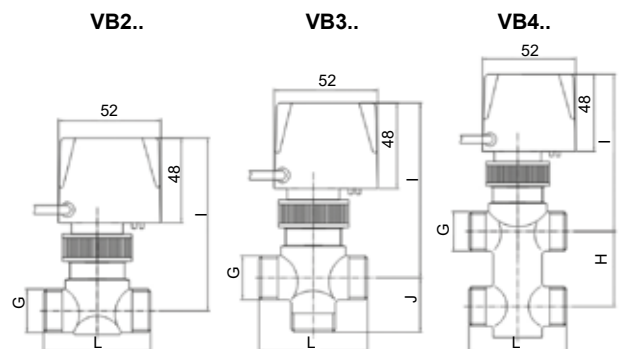



Description

The AVC series provides floating or proportional control in HVAC applications. The compact design of this actuator makes it suitable for installation in confined spaces, such as fan coil, chilled ceiling, manifolds, etc. The AVC series actuator is designed for field mounting onto VB terminal unit valves. Due to the innovative concept of different strokes setting the AVC can be installed over most of the terminal unit valve in the market.

Technical specification

Power supply	230 VAC or 24 VAC/DC, 50-60 Hz
Power consumption	1,5 W for 24 VAC/DC, 2,2 W for 230 VAC
Signal input	0 (2)...10 V / 0 (4)... 20 mA selectable via dip-switches
Force	120 N +30% -20%
Action	floating and proportional
Max stroke	6,3 mm
Actuator speed	13 sec/mm
Connection	Metal ring M30 x 1.5
Cable	1,5 m cable length 3 x 0,35 mm ²
Maintenance	Free
Status indications	Internal LED
Protection degree	IP43
Working range RH	non-condensing
Working range °C	0...+50°C
Storage temperature	-20...+65°C
Standards	CE-conformity, RoHS



Models	Power supply	Action
AVC230	230 VAC	floating
AVC24	24 VAC	floating
AVC24M	24 VAC/VDC	proportional

LED indicator



AVC24 AVC230

- OFF
- Green • Verde
- Moving to Position
• In movimento verso la posizione
- End stroke reached
• Fine corsa raggiunto



AVC24M

- OFF
- Green • Verde
- Moving to Position
• In movimento verso la posizione
- Position reached
• Posizione raggiunta
- Red • Rosso
- Power on Calibration
• Calibrazione in corso
- 4-20mA / 2-10 VDC
• Failure signal loss
• Mancanza di segnale



Electrical wiring

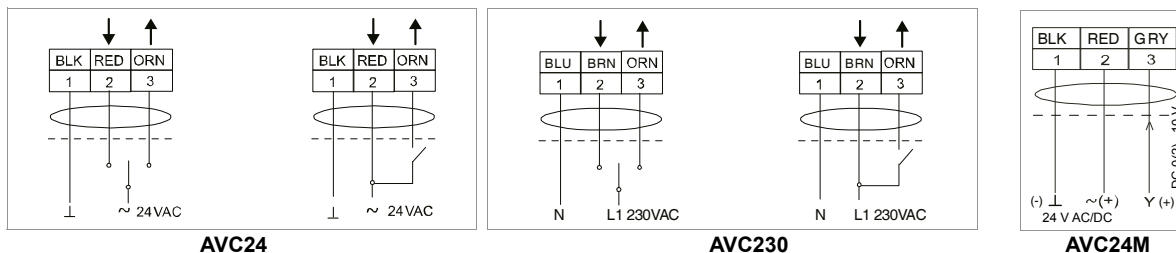

At power up, the actuator automatically runs through its full stroke to detect and memorize the end limits. After calibration, it positions itself according to the control signal, with LED indicating operating status.

Settings for proportional version

1	OFF	ON	2	OFF	ON	3	OFF	ON	4	OFF	ON	5	OFF	ON	6	OFF	ON		
0...10VDC		0...20mA		0...5VDC		5...10VDC		2...10VDC		4...20mA		DA		RA		LIN		Eq%	
VDC		mA																	
1: CONTROL SIGNAL RANGE				4: ACTION				5: CURVE				6: SIGNAL TYPE							

<p>UMES Upper Mechanical End Stroke</p>	<p>LMES Lower Mechanical End Stroke</p>
<p>2,8 mm</p>	<p>UMES 14,5 mm</p>
<p>5,3 mm</p>	<p>LMES 8,2 mm</p>
<p>5,8 mm</p>	

DIP Switch 1, 2, 3, and 6: DIP switch 1, 2, and 3 allow the user to change the analog input ranges. To change from voltage analog input to current analog input set DIP switch 6 accordingly.
DIP Switch 4: DIP switch 4 allows the user to change the action of the actuator in relation to the analog input. DIP switch 4 is off (DA) when the signal increases and the actuator stem extends.
DIP Switch 5: DIP switch 5 allows the user to change the control characteristic of the actuator in order to obtain a combination of valve and actuator Linear or Almost Equal Percentage.
DIP Switch 5 OFF (Linear): When DIP switch 5 is set to Off, we recommend you use the valve with the linear or equal percentage control characteristic.
DIP Switch 5 ON (Almost Equal Percentage): When DIP switch 5 is set to On, we recommend you use the valve with the quick opening or on/off control characteristic.

Dimensions (mm)

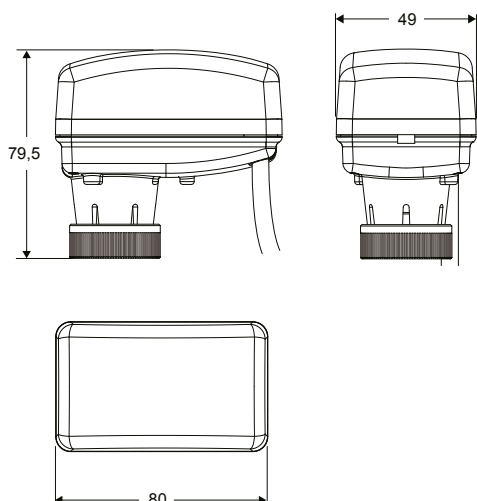

Description

The AVS series provides on-off and proportional control in HVAC applications. The compact design of this actuator makes it suitable for installation in confined spaces, such as fan coil, chilled ceiling, manifolds, etc. The AVS series actuator is designed for field mounting onto VS terminal unit valves. Due to the innovative concept the AVS can be installed over most of the terminal unit valve in the market.

Technical specifications

Power supply	24 VAC or 230 VAC ±10%, 50 Hz
Power consumption	2 W or 3 W proportional version
Signal input	0 (2)...10 VDC / 0 (4)... 20 mA selectable by jumper
Feedback	0 (2)...10 VDC
Torque	See schedule
Action	on-off and proportional
Max stroke	90°
Electrical connection	50 cm cable length
Materials	PC cover, PA66 housing
Maintenance	Free
Protection degree	IP54
Protection class	I
Working range RH	5...95% no condense
Working range °C	-10...+50°C
Storage temperature	-40...+50°C
Fluid temperature	+5...95°C
Standards	CE-conformity, RoHS



Models	Power supply	Torque	Action	Wiring	Running time
AVS2A2	24 VAC	2 Nm	ON-OFF	2-wire	40-50 sec.
AVS2A3	24 VAC	2 Nm	ON-OFF	3-wire	40-50 sec.
AVS2B2	230 VAC	2 Nm	ON-OFF	2-wire	40-50 sec.
AVS2B3	230 VAC	2 Nm	ON-OFF	3-wire	40-50 sec.
AVS3AM	24 VAC	3,5 Nm	proportional		40-50 sec.

Electrical wiring

AVS2A2 AVS2B2

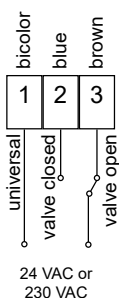

AVS2A3 AVS2B3

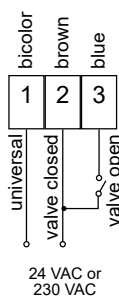

AVS3AM

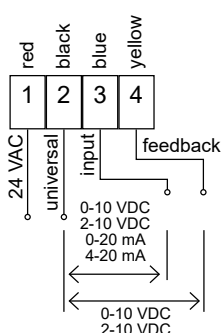

Installation instructions

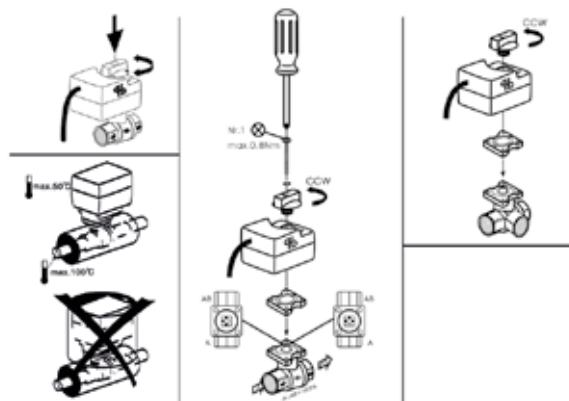



Settings of proportional version

- Function of each short-circuit socket: W1: mA /VDC. W2 to select the signal type of the input signal of socket J1 (COM VDC/mA). W2: 0-10 VDC (0-20 mA) 2 -10 VDC (4-20 mA). W1 to select the signal type of input signal J1. W3: DA (direct) RA (reverse). Select direct way: when the input signal of J1 increases, the valve opens gradually; when the signal decreases, the valve closes gradually. Select the reverse way: when the input signal of J1 increases, the valve closes gradually and when the signal decreases, the valve opens gradually.
- Function of each J1: COM 24 VDC: power(24VAC) input terminal. COM VDC /mA: input signal, 0-10 VDC (0-20 mA) or 2-10 VDC (4-20 mA) COM FB: feedback signal output terminal, the value is 0-10 VDC or 2-10 VDC, which is equal to the input signal when the valve does not work. J2: 3 cores. Connected potentiometer gives the valve state. Phase 1, 2 and 3 of potentiometer and phase 1, 2 and 3 of J2 are connected respectively. J3: 3 cores. Connect to 24 VDC motor.
- „Work“ indicator status: Normal working status: slow flashing (on in 1 second and off in 1 second). Adaptive working state: fast flashing (on in 0.25 second and off in 0.25 second). Adaptive failure status: lamp flashes twice quickly and is off for a long time (on/off twice in 0.25 second, off at 1.25 seconds).
- The motor rotation direction indicator: When D50 lamp is on, the valve turns to close. When the valve turns to the end, the microswitch S50 works and the lamp turns off automatically after the valve stops working in 25 seconds. When D60 lamp is on, the valve turns to be open. When the valve turns to the end, the microswitch S60 works and the lamp turns off automatically after the valve stops working in 25 seconds.
- Process of „adaptive“ stroke: Adjust the position of the potentiometer to set the valve stroke in the middle of the potentiometer. Press and hold the „adaptive“ key for 3 seconds to enter the working status. The „work“ lamp flashes (on in 0.25 second and off in 0.25 second). The valve first moves in the closing direction until reaching the end. When the valve does not move for 25 seconds, it moves to the opening direction until reaching the end. If the valve does not move for 25 seconds, the adaptation process ends. If the adaptation is successful (the adaptive data replaces the previous data), it returns to the normal working state. If the adaptation fails (the adaptive data does not replace the previous data), it comes to the adaptation failure state. The „work“ lamp flashes twice and is off for a long time (on/off twice in 0.25 second, off at 1.25 seconds). User can press the „adaptive“ key for 3 seconds to enter the adaptive working state or turn off and then turn on to enter the normal working state.

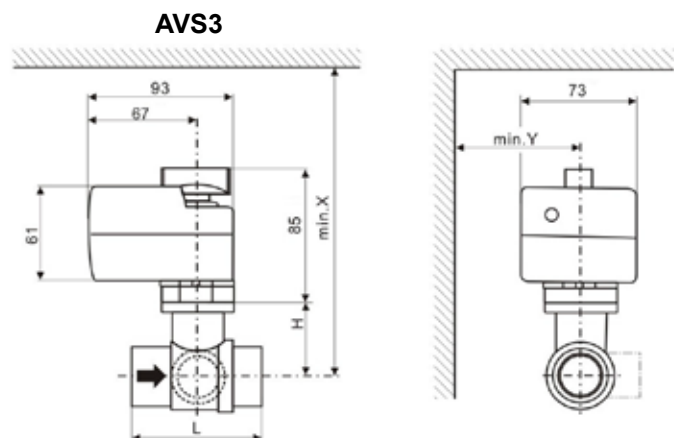
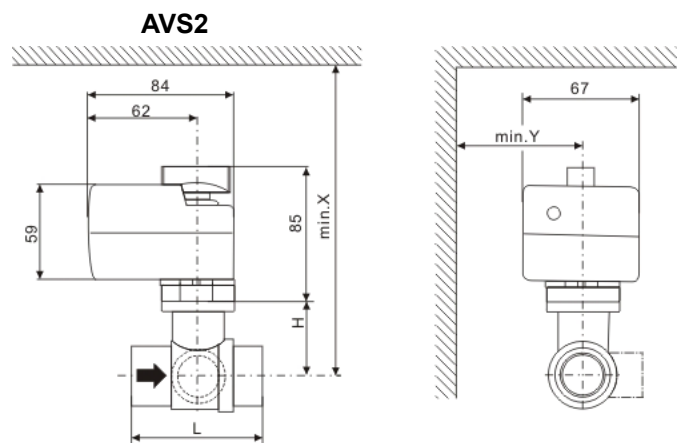
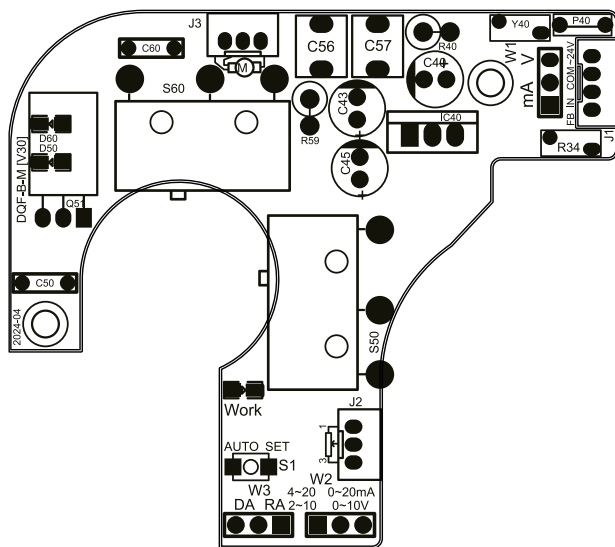

Dimensions (mm)

Valve	mm	in	L	H	X	Y
VS215	15	1/2	63	30	190	75
VS220	20	3/4	73	35	190	75
VS225	25	1	94	38	193	75
VS315	15	1/2	63	32	190	75
VS320	20	3/4	66	35	190	75
VS325	25	1	94	38	193	75



Description

The valve serie VZ coupled to the actuator serie SVZ is suitable for applications in heating, cooling and air conditioning systems of domestic and commercial areas and is typically used on fan coil and air handling units. The actuator can be mounted after valve body has been installed onto the system.

Technical specifications valve VZ

Medium	Hot and chilled water, water with up to 50% glycol
Fluid temperature	+2...+94°C
Nominal pressure	16 bar
Stroke	3,5 mm
Leakage	< 0,02% of KVs
Connection type	Female thread
Installation position	See drawing
Maintenance	Free
Valve body	Forged brass
Valve stem	Stainless steel 302
Sealing	NBR
Dimensions and weights	See schedule

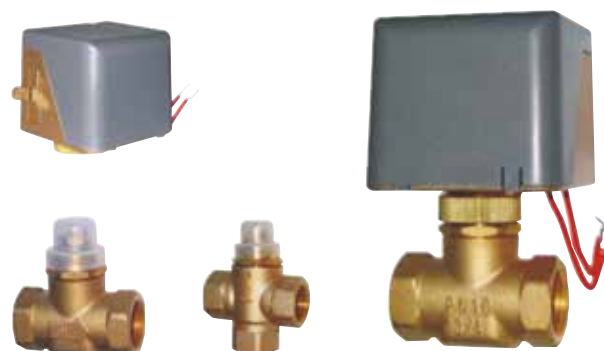

Models	Thread	Ways	KVs	Max. differential pressure (bar)
VZ215	G 1/2	2	2,5	2,5
VZ220	G 3/4	2	3,5	1,0
VZ225	G 1	2	4,0	0,6
VZ315	G 1/2	3	2,5	2,5
VZ320	G 3/4	3	3,5	1,0
VZ325	G 1	3	4,0	0,6

Technical specifications actuator SVZ

Power supply	230 V AC, 24 V AC 50-60 Hz
Power consumption	7 W
Control signal	On/Off, 2 points, spring return
Running time	Opening ≤ 10 s, closing ≤ 5 s
Materials	Aluminium base. Cover: ABS self-extinguishing
Protection degree	IP20
Protection class	II
Working range °C	0...+60°C
Working range RH	5...95% RH, non-condensing
Standards	CE-conformity, RoHs

Models	Power supply	Auxiliary switch
SVZ230	230 V AC	-
SVZ230C	230 V AC	•
SVZ24	24 V AC ±10%	-
SVZ24C	24 V AC ±10%	•



Electrical wirings

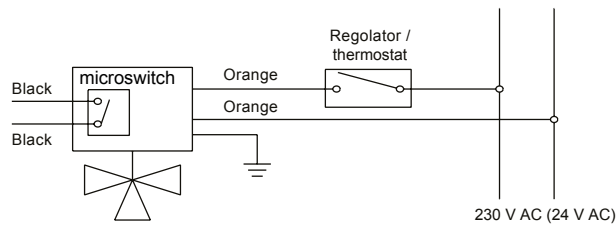

Installation

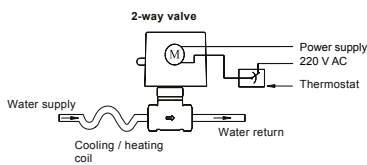

fig. 1

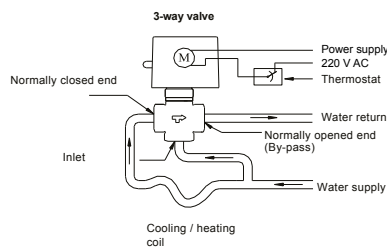

fig. 2

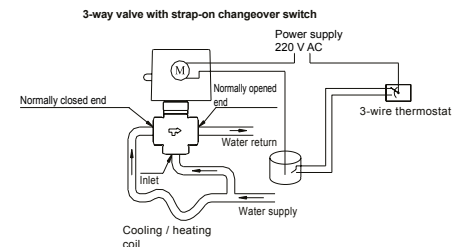

fig. 3

2-way valves normally closed: the flow direction is shown in the figure (the valve closes against the water flow, fig.1).

3-way diverting valves: inlet is the normally closed end and the normaly open end is the by-pass port (the inlet part is unmarket, fig. 2 and 3)

Important notes for fan-coil installations:

Valve motor and gear train will not operate properly when wet. Motor housing must be protected from drip. The actuator with valve body do not need to be protected against condensation when installed horizontally or up to 85°C from upright potision (see figure on side). When mounted in vertical piping, motor housing must be protected from drip.

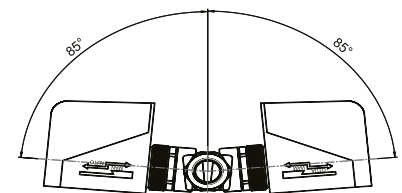

Dimensions (mm)

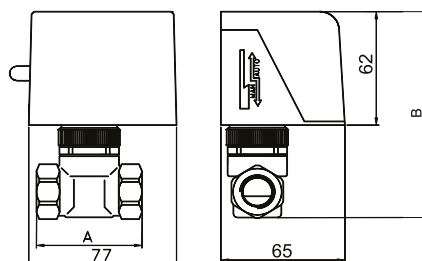

Models	Dimensions in mm		Weight kg
	A	B	
VZ215	55	113	0,60
VZ220	66	124	0,65
VZ225	71	129	0,70
VZ315	55	128	0,60
VZ320	66	137	0,65
VZ325	71	145	0,70

Description

The ball valves VS serie are control valves with perfect sealing, that thanks to the shaping of the adjustment disk guarantees a percentage flow characteristic.



Technical specifications

Valve type	BSP 2 way, 3 way mixing / diverting
Fluid	Hot and cold water (with glycole max. 50%) and 15% (103 kPa) saturated steam
Fluid temperature	-5...+120°C at an ambient temperature of 40°C
Nominal pressure	PN20
Leakage	0,01 % of KVs
Control flow characteristics	Equal-percentage A-C, linear for port B bypass
Leakage	Perfect sealing
Max. closing pressure	13 bar
Max. diff. pressure (close-off)	See table below
Maintenance	Free
Valve	Forged brass (from DN15 to DN50), cast iron (DN65 and DN80)
Plug	Stainless steel V2A
Stem	Brass
Seat	EPDM
Seal	HNVR double O-ring
Standards	CE-conformity, RoHS

Models		DN	KVs	Actuator type(*)	Actuator type	Actuator type with spring return(**)
2-way	3-way					
VS215	VS315	15	4.0	S4..	S5..V	SR5..
VS220	VS320	20	6.3	S4..	S5..V	SR5..
VS225	VS325	25	10	S4..	S5..V	SR5..
VS232	VS332	32	16	S8..	S5..V	SR10..
VS240	VS340	40	25	S8..	S10..V	SR10..
VS250	VS350	50	40	S16..	S10..V	SR15..
VS250B	VS350B	50	63	S16..	S10..V	SR15..
VS265	-	65	63	S16..		SR15..
VS280	-	80	100	S16..		SR15..
VS2100	-	100	120	S32..		-

(*) For coupling valve and actuator adapter VSA is required

(**) For coupling valve and spring return actuator adapter VSAR is required

Maximum close-off pressure [kPa] with actuator

Model	torque (Nm)	DN15	DN20	DN25	DN32	DN40	DN50
S5..	5	1000	1000	1000	1000	690	400
S10..	10	1400	1400	1400	1400	1000	1000



Control flow characteristics

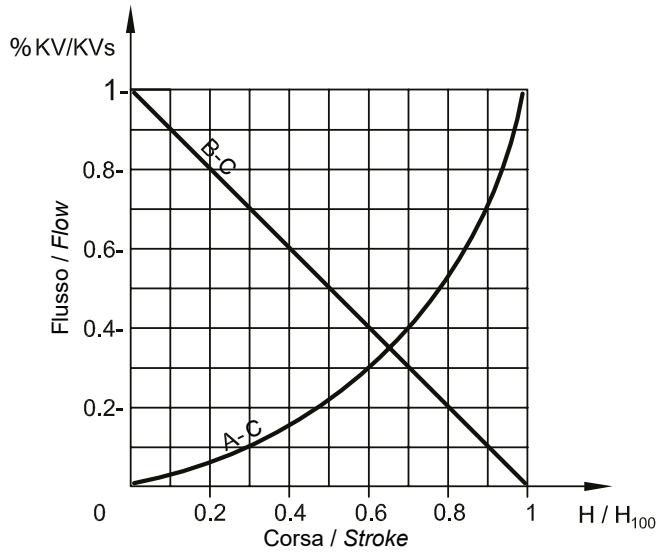

A-C equal-percentage way
 B-C bypass lineare way
 3-way used as mixing inlet in A and B,
 outlet C
 3-way used as diverting inlet in A,
 outlet from B or C

C way constant flow
A way variable flow
B (bypass) way variable flow

Installation

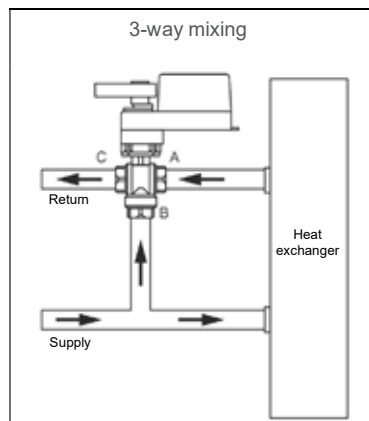
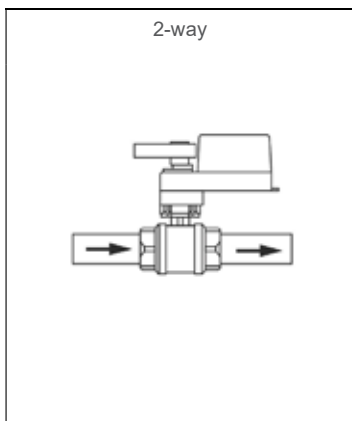

Mixing application:
 Fluid enters through two inlets
 (A & B) and exits through one
 outlet (C).

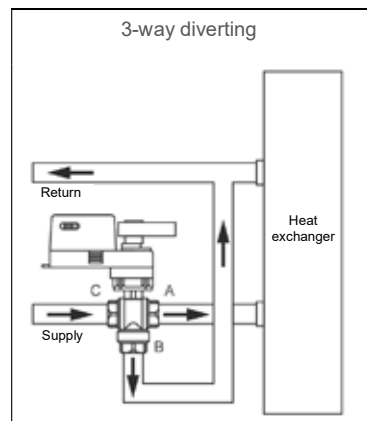

Diverting application:
 Fluid enters through one inlet
 (C) and exits through two
 outlets (A & B).



■ Dimensions with actuator S4...S32 (mm)

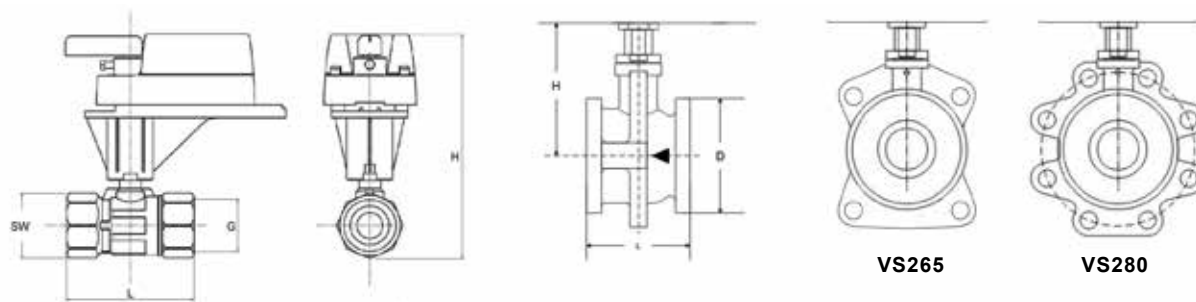

DN mm	G	L	H	SW	D	Flange	Weight 2 way (kg)	Weight 3 way (kg)
15	G 1/2	60	179,20	26	-	-	0,2	0,25
20	G 3/4	67	187,80	32	-	-	0,35	0,4
25	G 1"	89	193,80	39	-	-	0,55	0,7
32	G 1" 1/4	99	204	48	-	-	0,85	1,1
40	G 1" 1/2	106	212,80	56	-	-	1,2	1,4
50	G 2"	128	224,70	70	-	-	1,95	2,2
65	Flange 145	97	136	-	105	4-18	4,5	-
80	Flange 160	108	140	-	125	8-18	6,8	-
100	Flange 180	120	202	-	125	8-18	8,6	-

■ Dimensions with actuator S5..V and S..10V (mm)

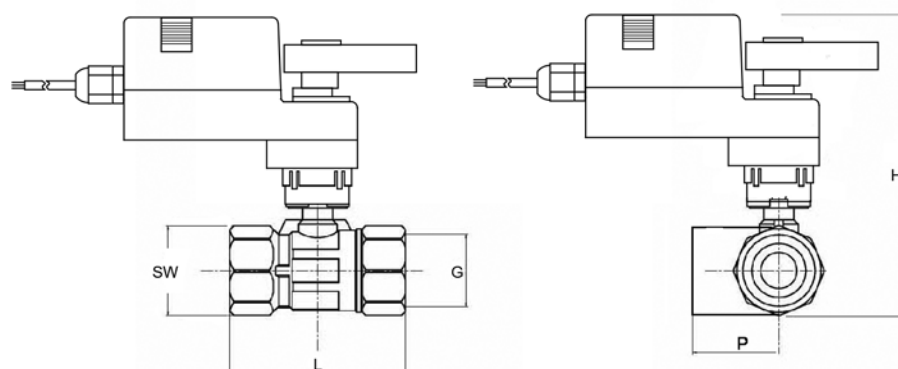

DN mm	G	L	H	SW	P	Weight 2 way (kg)	Weight 3 way (kg)
15	G 1/2	60	137	26	31	0,2	0,25
20	G 3/4	67	142	32	32	0,35	0,4
25	G 1"	89	148	39	46	0,55	0,7
32	G 1" 1/4	99	159	48	49	0,85	1,1
40	G 1" 1/2	106	181,60	56	52	1,2	1,4
50	G 2"	128	192,70	70	69	1,95	2,2
65	Flange 145	97	136	-	-	4,5	-
80	Flange 160	108	140	-	-	6,8	-
100	Flange 180	120	202	-	-	8,6	-

Description

The electric actuator series S5..V for ball valves are used in heating, refrigeration and air conditioning systems.

- For valves from DN15 to DN32
- Power supply 24 VAC / DC and 230 VAC
- Function: open / closed or 3 point and proportional action
- Shaft dimension □ 9 mm square (fixed)
- Direction of rotation selectable by switch
- Actuator with 1 m connection cable
- Optional 1 adjustable SPDT auxiliary switch



Technical specifications

Models		S5AV	S5BV	S5AMV
Nominal torque	Nm		5	
Power supply	V	24 AC/DC ±10%	230 AC	24 AC/DC ±10%
Frequency	Hz		50/60	
Power consumption				
- in operation	W		4.0	
- end position	W		2.0	
Rated power	VA		14	
Running time	s	70...100	70...100	60...90
Electrical connection			1 m PVC cable	
Auxiliary switch rating			3 (1.5) A / 250 VAC	
Sound power level	max. db (A)		40	
Control signal (input)		2-3 point	2-3 point	0(2)...10 VDC
Position signal (output)				0...10 VDC
Life Cycle	rotations		60.000	
Angle of rotation			90° (95° mechanical limitation)	
Direction of rotation			CW / CCW	
Protection class		III	II	III
Protection degree			IP54	
Working range °C			-20...+50°C	
Working range RH			5...95% RH, non-condensing	
Storage temperature			-30...+60°C	
Maintenance			free	
Weight	g		800	
Standards			CE-conformity, RoHs	
Option		suffix S for models with 1 SPDT auxiliary switch		

Operate the manual control without applying excessive force, keeping the release button pressed for the entire stroke of movement. Rotate slowly and smoothly, avoiding jerky movements or sudden changes in direction.



Electrical wirings

Wiring diagram S5AV / S5BV

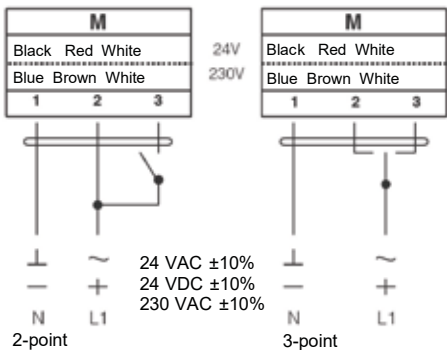

2-point

3-point

Connect via safety isolating transformer!

Wiring diagram S5AMV

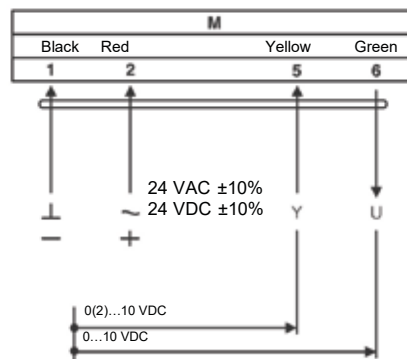

Wiring diagram S5AV / S5BV
Auxiliary switch

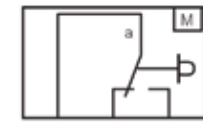

Yellow Green Blue
S1 S2 S3

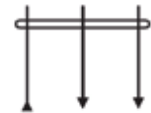

3 (1.5) A / 250 VAC
Actuator at 0° position

Wiring diagram S5AV / S5BV
Parallel connection

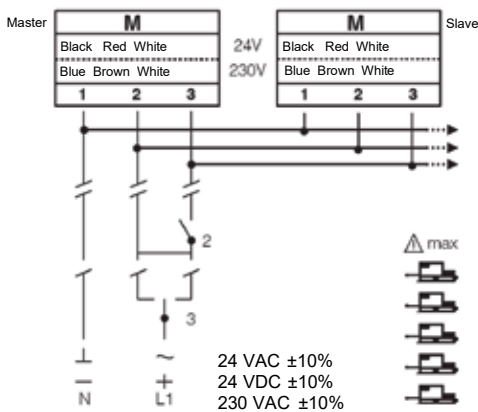

Parallel connection of maximum 5 S5..V (S1) actuators is possible. Power consumption must be observed!

Wiring diagram S5AMV
Parallel connection

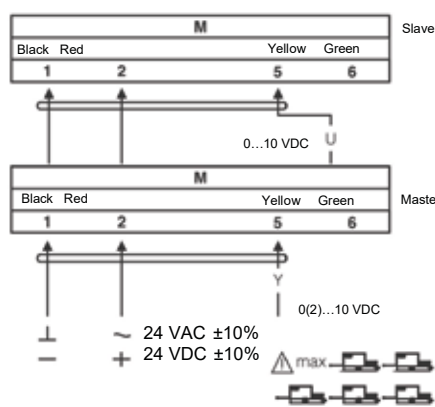

During parallel operation, the output signal (terminal 6, 0...10 VDC) of the master actuator must be connected to terminal 5 of the next slave actuator.

3-way diverting

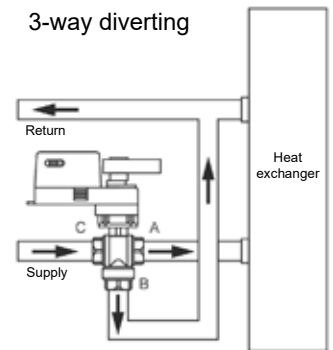

Diverting application:
Fluid enters through one inlet (C) and exits through two outlets (A & B).

Installation

Mixing closed

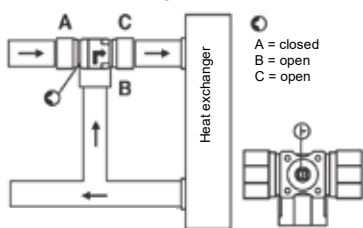

Ball valve actuators must operate CCW!

Mixing open

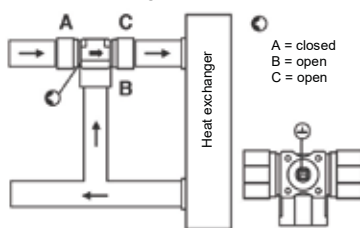

Actuator position

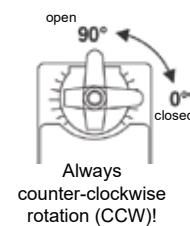

Auxiliary switch

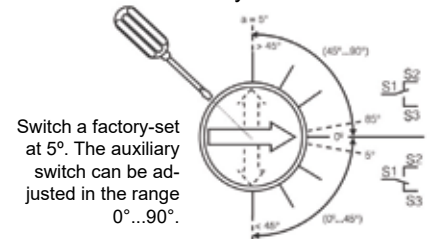

Change of rotation direction

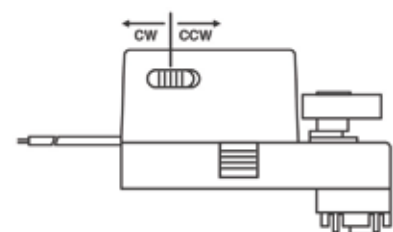

Factory setting: clockwise (CW). Direction of rotation can be changed by toggling between CW/CCW switch on the actuator housing.



Control flow characteristics

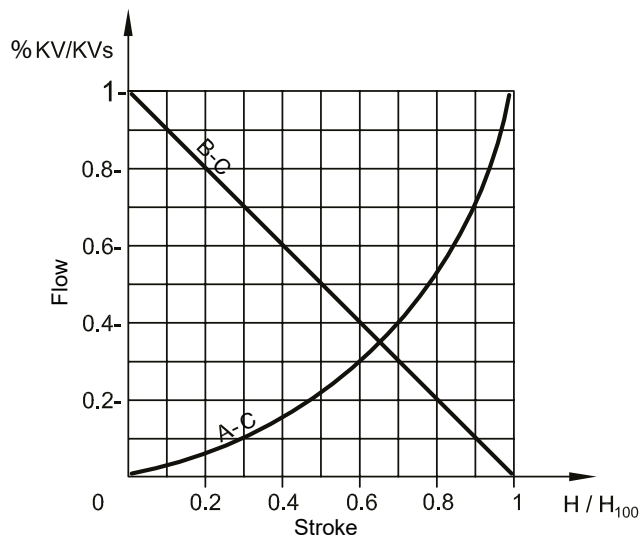

A-C equal-percentage way
 B-C bypass lineare way
 3-way used as mixing inlet in A and B, outlet C
 3-way used as diverting inlet in C, outlet from A and B

C way constant flow
A way variable flow
B (bypass) way variable flow

Dimensions (mm)

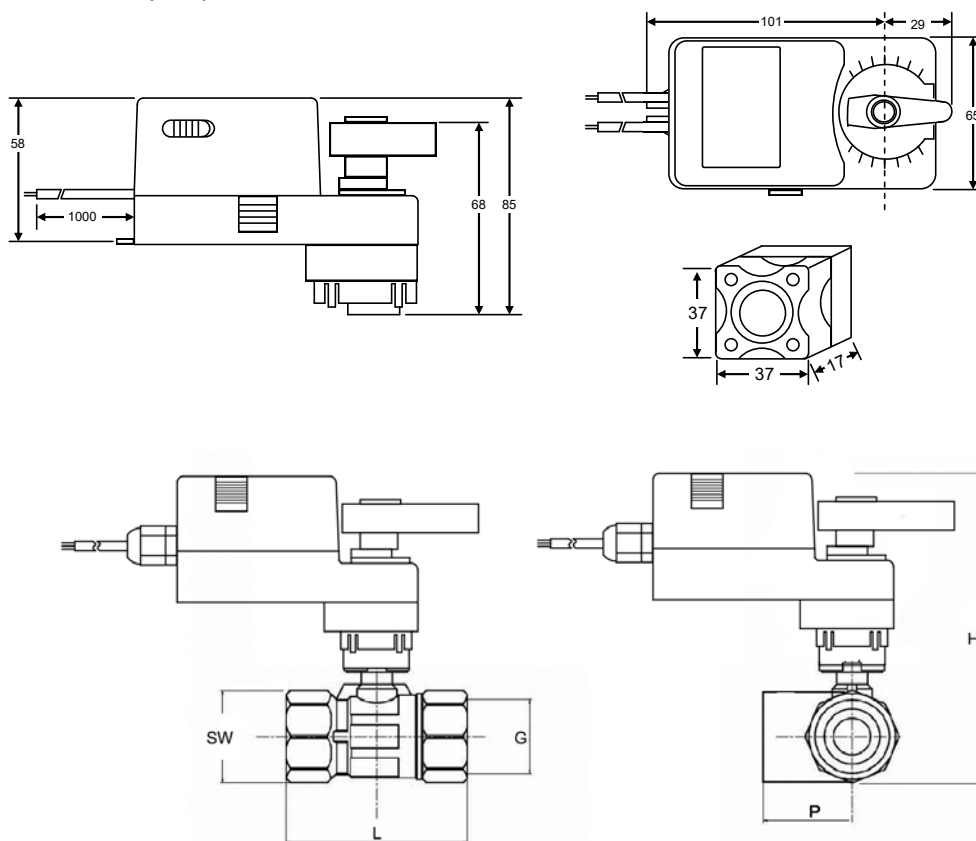

DN mm	G	L	H	SW	P	weight 2 way (kg)	weight 3 way (kg)
15	G 1/2	60	137	26	31	0,2	0,25
20	G 3/4	67	142	32	32	0,35	0,4
25	G 1"	89	148	39	46	0,55	0,7
32	G 1" 1/4	99	159	48	49	0,85	1,1

Description



The electric actuator series S10..V for ball valves are used in heating, refrigeration and air conditioning systems.

- For valves from DN40 to DN50
- Power supply 24 VAC / DC and 230 VAC
- Function: open / closed or 3 point and proportional action
- Shaft dimension □ 9 mm square (fixed)
- Direction of rotation selectable by switch
- Actuator with 1 m connection cable
- Optional 1 adjustable SPDT auxiliary switch



Technical specifications

Models		S10AV	S10BV	S10AMV
Nominal torque	Nm		10	
Power supply	V	24 AC/DC ±10%	230 AC	24 AC/DC ±10%
Frequency	Hz		50/60	
Power consumption				
- in operation	W		6.0	
- end position	W		4.0	
Rated power	VA		14	
Running time	s		100...150	
Electrical connection			1 m PVC cable	
Auxiliary switch rating			3 (1.5) A / 250 VAC	
Sound power level	max. db (A)		40	
Control signal (input)		2-3 point	2-3 point	0(2)...10 V DC 0(4)...20 mA
Position signal (output)				0...10 VDC
Life Cycle	rotations		60.000	
Angle of rotation			90° (95° mechanical limitation)	
Direction of rotation			CW / CCW	
Protection class		III	II	III
Protection degree			IP54	
Working range °C			-20...+50°C	
Working range RH			5...95% RH, non-condensating	
Storage temperature			-30...+60°C	
Maintenance			free	
Weight	g		1100	
Standards			CE-conformity, RoHs	
Option			suffix S for models with 1 SPDT auxiliary switch	

Operate the manual control without applying excessive force, keeping the release button pressed for the entire stroke of movement. Rotate slowly and smoothly, avoiding jerky movements or sudden changes in direction.



Electrical wirings

Wiring diagram S10AV / S10BV

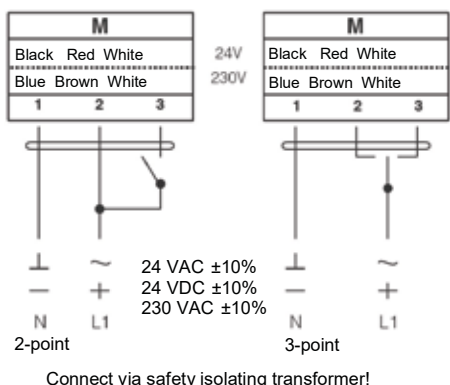

Wiring diagram S10AMV

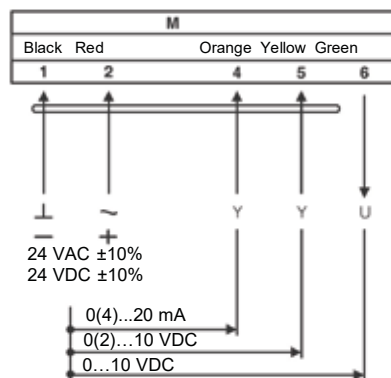

Wiring diagram S10AV / S10BV
Auxiliary switch

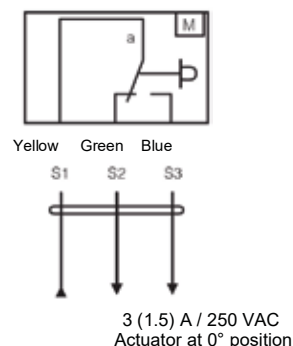

Wiring diagram S10AV / S10BV
Parallel connection

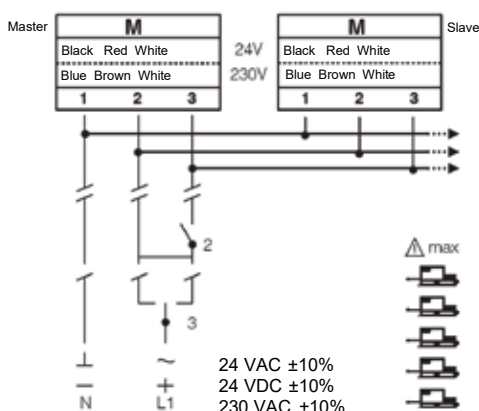

Parallel connection of maximum 5 S10..V (S1) actuators is possible. Power consumption must be observed!

Wiring diagram S10AMV
Parallel connection

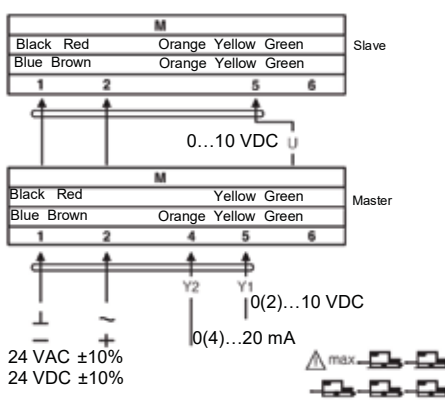

During parallel operation, the output signal (terminal 6, 0...10 VDC) of the master actuator must be connected to terminal 5 of the next slave actuator.

3-way diverting

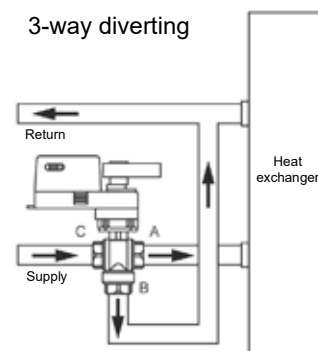

Diverting application: Fluid enters through one inlet (C) and exits through two outlets (A & B).

Installation

Mixing closed

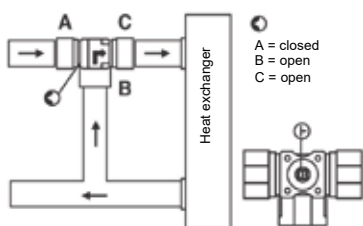

Ball valve actuators must operate CCW!

Mixing open

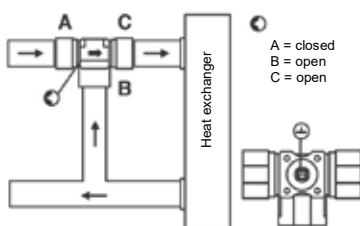

Actuator position

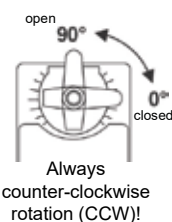

Auxiliary switch

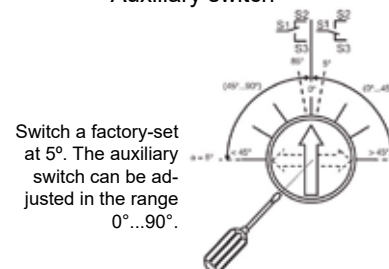

2-way closed 2-way open



3-way closed 3-way open

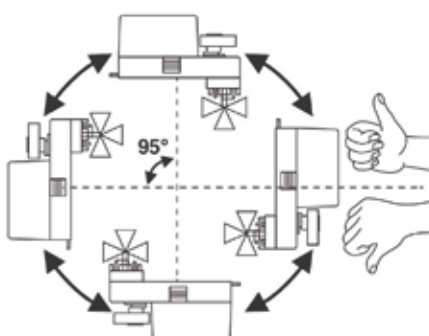

Change of rotation direction

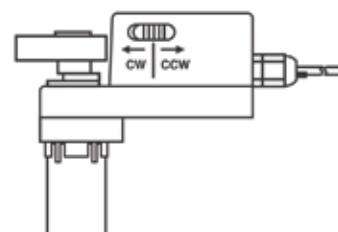

Factory setting: clockwise (CW). Direction of rotation can be changed by toggling between CW/CCW switch on the actuator housing.



Control flow characteristics

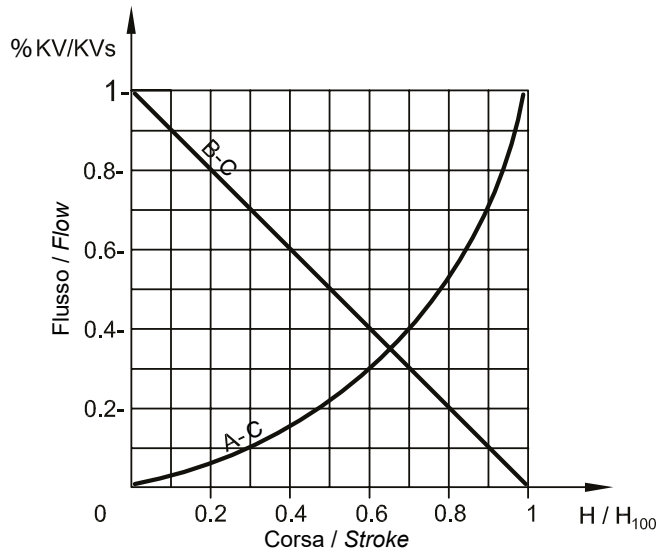

A-C equal-percentage way
 B-C bypass lineare way
 3-way used as mixing inlet in A and B, outlet C
 3-way used as diverting inlet in C, outlet from A and B

C way constant flow
A way variable flow
B (bypass) way variable flow

Dimensions (mm)

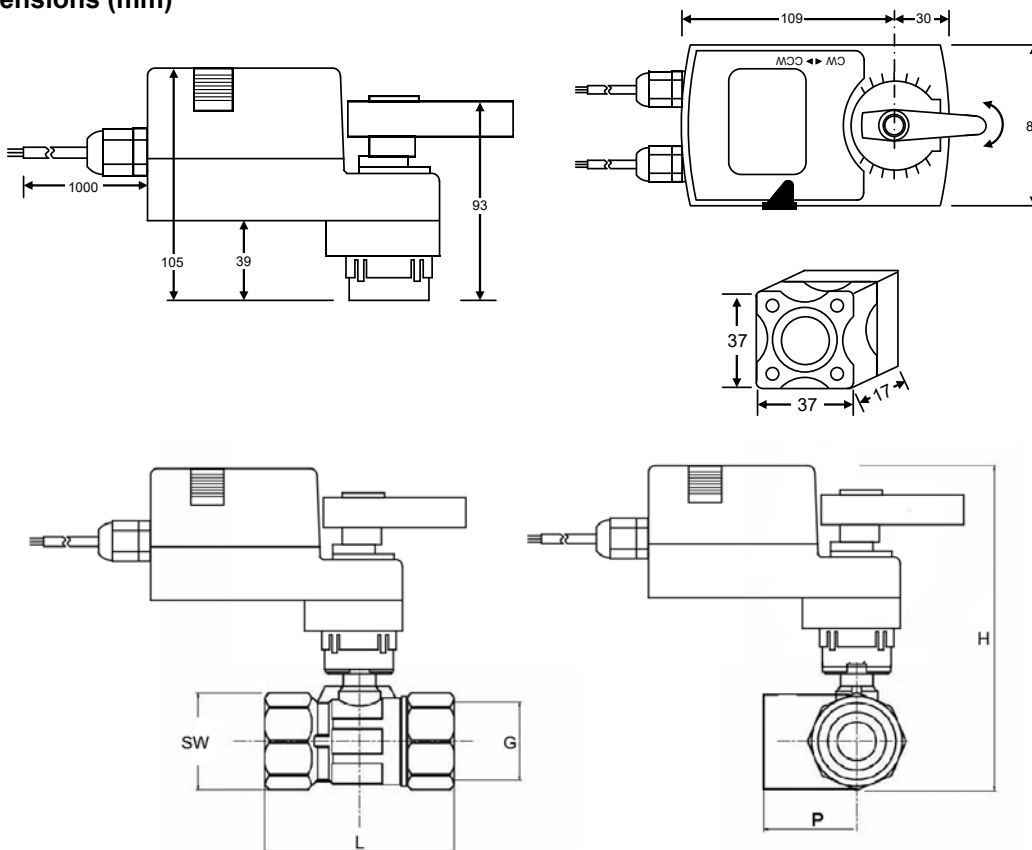

DN mm	G	L	H	SW	P	weight 2 way (kg)	weight 3 way (kg)
40	G 1" 1/2	106	181,60	56	52	1,2	1,4
50	G 2"	128	192,70	70	69	1,95	2,2
65	Flange 145	97	136	-	-	4,5	-
80	Flange 160	108	140	-	-	6,8	-
100	Flange 180	120	202	-	-	8,6	-

Description

The globe valves in brass serie VG are used in heating, refrigeration and air-conditioning systems for the flow control of heated or chilled water for domestic and industrial applications. The valves are motorized by the electric actuators serie AVG at 600 and 1000 N.

Technical specifications

Fluids type	Hot and cold water (with glycol max. 50%)
Fluid temperature	-10...100°C
Nominal pressure	1600 kPa max (16 bar)
Control flow characteristics	Equal-percentage (linear on angle way)
Rangeability	50 : 1
Leakage	< 0,05% of KVs
Connections	BSP female thread
Stroke	See schedule
Installation position	Horizontal or vertical
Maintenance	Free
Body	Brass
Plug	Brass
Valve stem	Stainless steel 302
Stem packing	PTFE
Dimensions and weight	See schedule

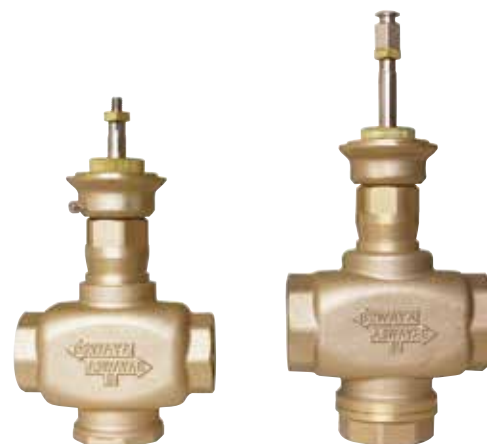

2 ways	Models		DN	KVs	Max differential pressure (bar) (*)	Stroke	Actuator
		3 ways					
VG215		VG315	15	4.0	2.5 (6)	15	AVG6(M)
VG220		VG320	20	6.3	2.5 (6)	15	AVG6(M)
VG225		VG325	25	8	2.5 (6)	20	AVG6(M)
VG232		VG332	32	16	2.5 (5.5)	20	AVG6(M)
VG240		VG340	40	25	2.5 (4.5)	20	AVG6(M)
VG250		VG350	50	40	2 (3)	20	AVG10(M)
VG265		VG365	65	63	2 (2.5)	20	AVG10(M)
VG280		VG380	80	78	2 (2)	20	AVG10(M)

(*) The values in the brackets are the max. differential pressure when valve is fully closed and actuator is still able to open or close the valve with security. In order to avoid wear between plug and seat, we recommend not to overcome the nominal values.

Caution

Before valves are mounted, make sure that pipes are clean, free from welding slags, that are perfectly lined up with valve body and not subjected to vibrations. The valve can be mounted in any position except upside-down. While assembling, respect the flow directions indicated by the arrows located on the valve body.

In the 2-way valve, when stem is up, the direct way is open, with stem down direct way is closed.

In the 3-way valve, when stem is up, the direct way is closed, with stem down direct way is open.



Installation

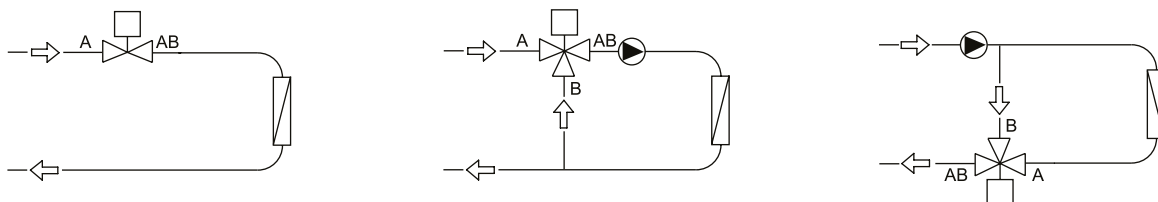

Control flow characteristics

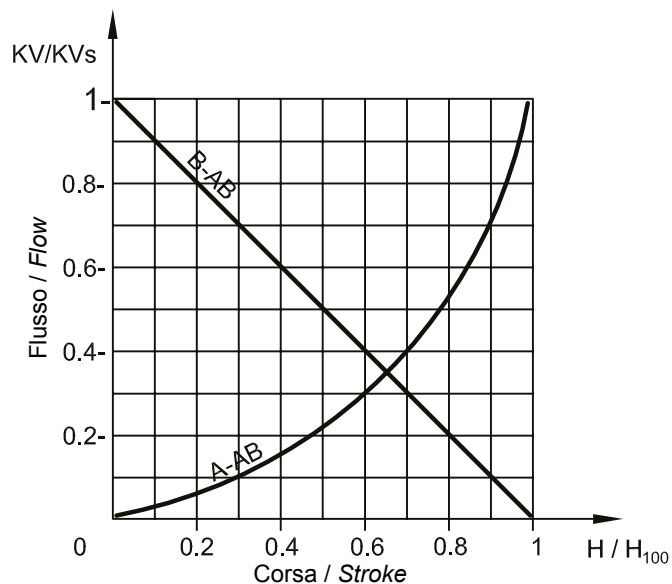

A-AB equal-percentage way
 B-AB bypass linear way
 3-way used as mixing inlet in A and B, outlet AB
 3-way used as diverting inlet in AB, outlet from A and B

AB way constant flow
A way variable flow
B (bypass) way variable flow

Dimensions and weights

Models	Thread	Dimensions (mm)			Weight kg
		A	B	C	
VG215	G1/2	84	38	130	2.2
VG315	G1/2	84	48	130	2.4
VG220	G3/4	84	38	130	2.3
VG320	G3/4	84	48	130	2.5
VG225	G1	104	48,5	135,5	3.5
VG325	G1	104	57,5	135,5	3.8
VG232	G1 1/4	110	50	138	3.7
VG332	G1 1/4	110	62,5	138	4.2
VG240	G1 1/2	120	55	144,5	4.4
VG340	G1 1/2	120	65,5	144,5	5.0
VG250	G2	134	58,5	143,5	5.7
VG350	G2	134	72,5	143,5	6.7
VG265	G2 1/2	160	72,5	152,5	8.5
VG365	G2 1/2	160	90	152,5	9.5
VG280	G3	180	80	158,5	9.5
VG380	G3	180	98,5	158,5	10.5

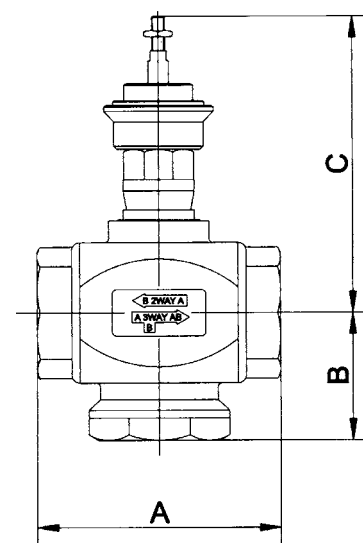

Description



The actuator series AVG6 has been designed to control the screwed globe valves series VG up to DN40. The actuator is equipped by a bidirectional synchronous motor at 600 N and available in ON-OFF, floating and proportional version. Fast and easy assembly. The actuator is equipped, for the proportional version, with a button for self-adjustment. The on-off switch is fitted with magnetic clutch.

Technical specifications

Power supply	See schedule
Electrical connection	Screw terminal
Torque	600 N
Max. stroke	20 mm
Running time	See schedule
Materials	ABS cover, self-extinguishing
Protection degree	IP54
Protection class	II
Working range °C	-10...+50°C
Storage temperature and humidity	-40...+50°C, 1...95% RH, non-condensing
Fluid temperature	< 150°C
Maintenance	Free



Models	Supply	Action	Consumption	Running time
AVG6	24 VAC, 50/60 Hz	on-off, floating	5,5 VA	70 sec. w/stroke 15 mm 92 sec. w/stroke 20 mm
AVG6B	230 VAC, 50/60 Hz	on-off, floating	7,5 VA	105 sec.
AVG6M	24 VAC, 50/60 Hz	proportional	5,5 VA	70 sec. w/stroke 15 mm 92 sec. w/stroke 20 mm

Electrical wiring

AVG6M (proportional)

W1: mA/VDC. Allows to choose whether the input signal is in voltage or in current. This jumper must be set along with W2 to select the input signal to J1.

W2: 4...20 mA (2...10 VDC) / 0...20 mA (0...10 VDC). This jumper must be set with W1 to select the input signal to J1.

W3: Reverse operation. Moving the jumper inverts the logic of operation compared to the input signal.

J1 Socket function

~24 V COM: 24 VAC power input

IN COM: Analog input signal, 0(2)~10 V or 0(4)~20 mA. W1 and W2 should be selected accordingly

FB COM: Analog feedback signal, 0(2)~10 V (load impedance > 500 Ω) or 0(4)~20 mA (load impedance ≤ 500 Ω), voltage and current automatically switch.

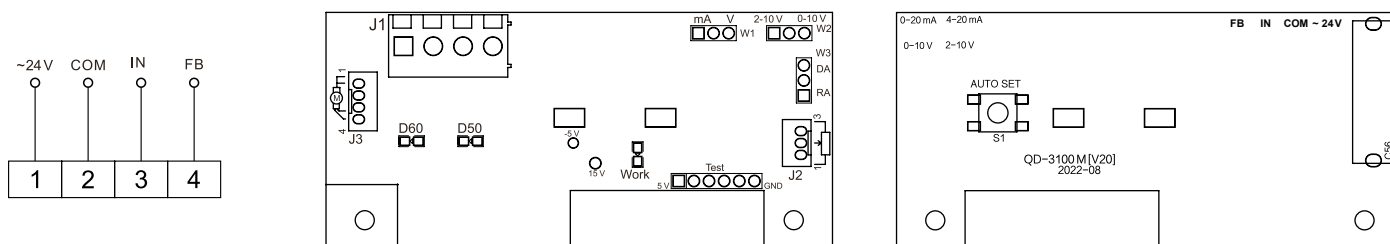

AVG6



AVG6, AVG6B (on-off, floating)

- 1: Common
- 2: Stem down (direct way open)
- 3: Stem up (direct way close)

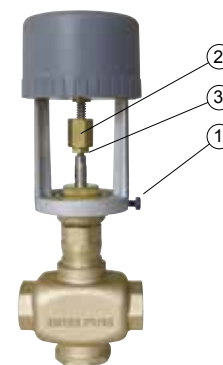
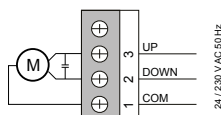

Installation

Place motor on the valve and, having placed in seat, tighten the locking screw (1).
Screw the brass nut of the motor shaft on the valve stem (2) and tighten the counter nut (3).
Make the electrical connections as shown in the previous diagrams and (only for AVG6M) provide for the jumper settings.

LED status indicator AVG6M

LED status	Equipment status
Flash slowly (1 sec on, 1 sec off).	Normal operating
Flash quickly (0,25 sec on, 0,25 sec off)	Self-adjustment
Flash twice (0,25 sec on and off twice, 1,25 sec off)	Self-adjustment failure
Flash once quickly (0,25 sec on and off, 1,75 sec off)	Motor timeout alarm

Motor rotation indication

D50 light on, valve shaft upward
D60 light on, valve shaft downward
Self-adjustment in an error state: flash twice quickly and off for a long time (0,25 sec on, 0,25 sec off, twice, then 1,25 sec off)

Self-adjustment

Note:

1. Do not start adaptation at the top of the valve stem. When adaptive, the voltage value of the simulated feedback signal 0-10VDC corresponds to the actual position value of the valve stem.
2. The adaptive process is best carried out when the valve is unloaded or lightly loaded. If the motor timeout alarm is triggered due to high resistance during adaptation, the adaptation will fail or incorrect valve travel will be obtained.

Press and hold the "AUTO SET" key for 3 sec, the actuator automatically will enter the self-adjustment. The LED "work" is flashing rapidly (0,25 sec on, 0,25 sec off). The valve shaft moves down to the bottom, and then maintains the position for 25 sec and then move upward until the upper point. This self-adjustment does not end until the valve shaft does not hold the final position for 25 sec.

Note: If the analog feedback signal does not meet the requirements during adaptive (that is, the potentiometer slips when the valve stem goes to both ends), the position of the potentiometer needs to be adjusted and then re-adaptive. Otherwise, although adaptive may be successful, the two ends of the drive will not go in place and cause the valve to close loosely.

To self-adaptation occurred (the previous data is overwritten), the actuator returns to normal operation. Otherwise (the previous data is not overwritten), will be reported the failure of the state of self-adjustment (0,25 sec on, 0,25 sec off, twice, then 1,25 sec off). You can hold down the "AUTO SET" key for 3 sec to retry the process of self-adjustment, or reboot (power cycle) of the actuator to return to normal working state.

Reasons for self-adjustment failure:

1. The adaptive valve stem stroke is too short, shorter than half of the maximum stroke.
2. The potentiometer wire connection is wrong or the line is disconnected. It is correct that the potentiometer value is maximum at the top of the valve stem and minimum at the bottom.

Dimensions (mm)

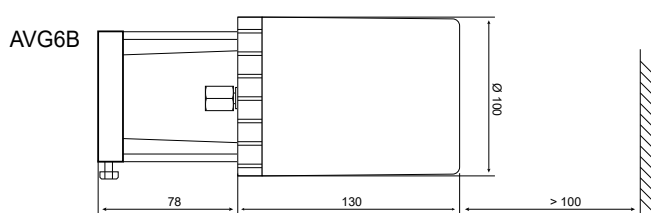
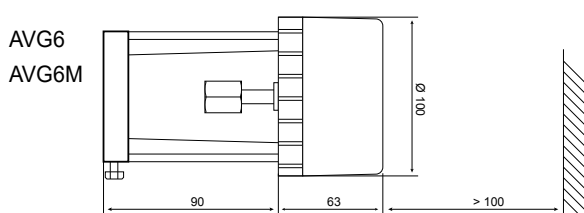



Description

The actuator series AVG10 has been designed to control the screwed globe valves series VG from DN50 up to DN80. The actuator is equipped by a bidirectional synchronous motor at 1000 N and available in ON-OFF, floating and proportional version. Fast and easy assembly. The actuator is fitted with manual override for the drive in case of power failure.

Technical specifications

Power supply	See schedule
Electrical connection	Screw terminal
Torque	1000 N
Max. stroke	20 mm
Running time	see schedule
Materials	ABS cover, self-extinguishing
Protection degree	IP54
Protection class	II
Working range °C	-10...+50°C
Storage temperature and humidity	-10...+50°C, 1...95% RH, non-condensing
Fluid temperature	< 150°C
Maintenance	Free



Models	Power supply	Action	Consumption	Running time
AVG10	24 V AC, 50/60 Hz ±10%	on-off, floating	5,8 VA	50 Hz, 160 sec. 60 Hz, 130 sec.
AVG10B	230 V AC, 50/60 Hz	on-off, floating	7,5 VA	
AVG10M	24 V AC, 50/60 Hz ±10%	proportional	5,8 VA	

Electrical wiring

AVG10M (proportional)

Terminal J1:

UP: When short-circuiting with 24 VAC COMMON, then the stem goes completely up (direct way close).

The position of W3 has no effect.

DOWN: When short-circuiting with 24 VAC COMMON, then the stem goes completely down (direct way open).

The position of W3 has no effect.

24 VAC POWER / 24 VAC COMMON: input terminal at 24 VAC. 24 VAC COMMON is connected with SIGNAL COMMON.

SIGNAL COMMON: Input signal 4...20 mA (2...10 V DC) / 0...20 mA (0...10 V DC). W2 and W4 must be set according to the input signal.

Feedback: Feedback signal. There is a signal 0...10 V DC or 2...10 V DC depending on the setting of W2.

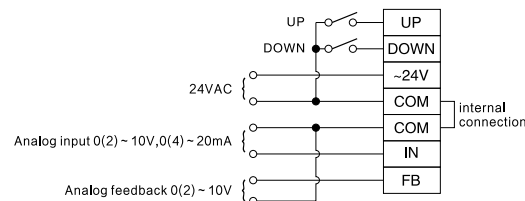

AVG10 (on-off, floating)

- 5: Common
- 4: Stem down (direct way open)
- 3: Feedback with stem down (24 V AC Ver.)
- 2: Stem up (direct way close)
- 1: Feedback with stem up (24 V AC Ver.)

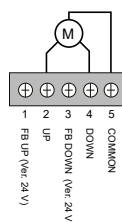

AVG10B (on-off, floating)

- 1: Common
- 2: Stem down (direct way open)
- 3: Stem up (direct way close)

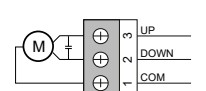

AVG10

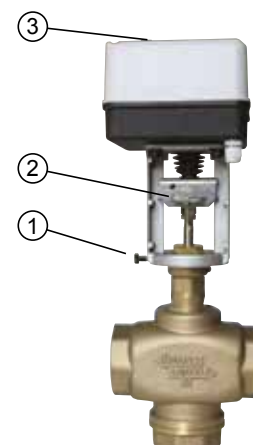

Installation

- Place motor on the valve and, having placed in seat, tighten the locking screw (1).
- Push the steel plate (2) and raise the valve stem or, alternatively, drive down the actuator shaft by manual override (3).
- Make the electrical connections as shown in the previous diagrams and (only for AVG10M) provide for the jumper settings.

Setting (AVG10M)

- W1:** 0%, 50%, 100%. Set the position of valve stroke in case of malfunction or failure of input signal.
 0% stem completely up 50% stem at halfway 100% stem completely down
 Moving the jumper W3, the situation is reversed.
 0% stem completely down 50% stem at halfway 100% stem completely up
- W2:** 4...20 mA (2...10 V DC) / 0...20 mA (0...10 V DC). This jumper must be set according to W4 to select the input signal to J1.
- W3:** Reverse operation. Moving the jumper inverts the logic of operation as compared to the input signal.
- W4:** mA / V DC. This jumper must be set along with W2 to select the input signal to J1.

LED Status Indicator (work): Normal operating status: flashing slowly (1 sec on, one sec off). During the self-adaptation of the actuator on the valve (after pressing S1 for at least 3 sec) flashes rapidly (0.25 sec on, 0.25 sec off).

Self-adjustment in an error state: blinks twice quickly and off for a long time (on 0.25 sec, off for 0.25 sec, twice, then off by 1.25 sec).

LED indication of the rotation direction of the motor:

When the LED **D50** lights up, the valve rod moves downward. When the valve rod reaches the bottom and hold the position for 25 seconds, the LED turns off.

When the LED **D60** lights up, the valve rod moves upward. When the valve rod reaches the top and hold the position for 25 seconds, the LED turns off.

Self-adjustment of the actuator to the valve. Each actuator must be adapted to the valve to which it is coupled. Do not start adaptation at the bottom of the valve stem.

Press and hold the "S1" key for 3 sec, the actuator automatically will enter the self-adjustment. The LED "work" is flashing rapidly (on 0.25 sec., off 0.25 sec.). The valve shaft moves down to the bottom, and then maintains the position for 25 sec and then move upward until the upper point. The self-adjustment does not end until the valve shaft does not hold the final position for 25 sec.

To self-adaptation occurred (the previous data is overwritten), the actuator returns to normal operation. Otherwise (the previous data is not overwritten), will be reported the failure of the state of self-adjustment (on 0.25 sec., off 0.25 sec., twice, then off by 1.25 sec.). You can hold down the "S1" key for 3 sec to retry the process of self-adjustment, or reboot (power cycle) of the actuator to return to normal working state.

Possible problems of self-adjustment:

- 1: It occurs in the case where the stroke is reached less than half the nominal stroke.
- 2: The connection of the potentiometer is wrong (terminal J2). Correct way: when the valve shaft is downward the potentiometer has the maximum value, when the valve shaft is upward the potentiometer has the minimum value.

Printed circuit board (AVG10M)

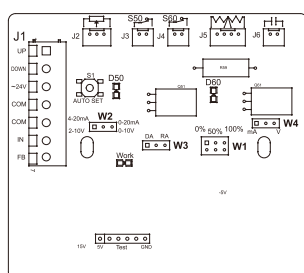

Dimensions (mm)

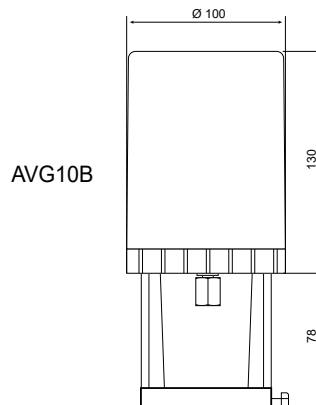
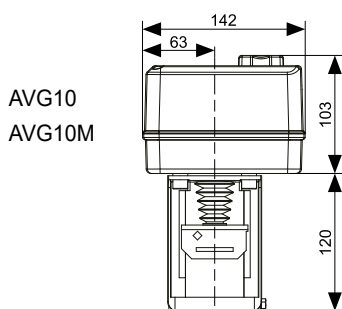

Description

The globe valves in stainless steel serie VGI are used in heating, refrigeration and air-conditioning systems for the flow control of heated or chilled water for domestic and industrial applications. The valves are motorized by the electric actuators serie AVGI10 at 1000 N.

Technical specifications

Fluids type	Hot and cold water (with glycol max. 50%)
Fluid temperature	-25...130°C
Nominal pressure	2500 kPa max (25 bar)
Control flow characteristics	Equal-percentage (linear on angle way)
Rangeability	50 : 1
Leakage	< 0,05% of KVs
Connections	BSP female thread
Stroke	22 mm
Installation position	Horizontal or vertical
Maintenance	Free
Body	Stainless steel 304
Plug	Stainless steel 304
Valve stem	Stainless steel 304
Stem packing	PTFE + O-ring EPDM
Dimensions and weight	See schedule



2 ways	Models		DN	KVs	Max diff. pressure (bar) (*)			Stroke mm	Actuator
	3 ways				2 ways	3 ways (M)	3 ways (D)		
VGI215	VGI315		15	4.0	5 (5)	5	2	22	AVGI10(M)
VGI220	VGI320		20	6.3	5 (5)	5	2		
VGI225	VGI325		25	8	5 (12.3)	5	2		
VGI232	VGI332		32	12	5 (7.5)	5	2		
VGI240	VGI340		40	20	3.5 (3.5)	3.5	1.5		
VGI250	VGI350		50	30	3 (3)	3	1		

(*) In order to avoid wear between plug and seat, we recommend not to overcome the nominal values.

Caution

Before valves are mounted, make sure that pipes are clean, free from welding slugs, that are perfectly lined up with valve body and not subjected to vibrations. The valve can be mounted in any position except upside-down. While assembling, respect the flow directions indicated by the arrows located on the valve body.

In the 2-way valve, when stem is up, the direct way is open, with stem down direct way is closed.

In the 3-way valve, when stem is up, the direct way is closed, with stem down direct way is open.



Installation

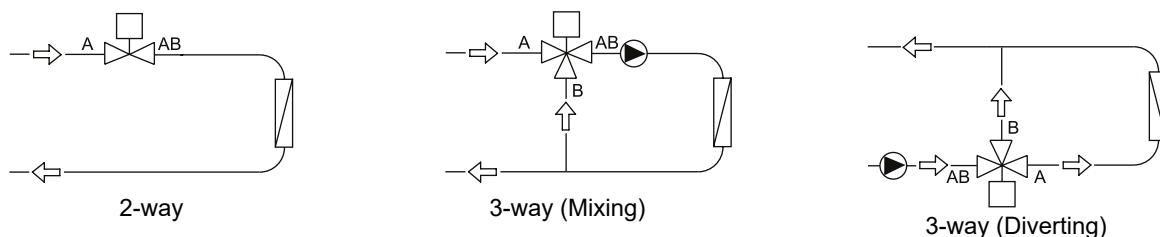

Control flow characteristics

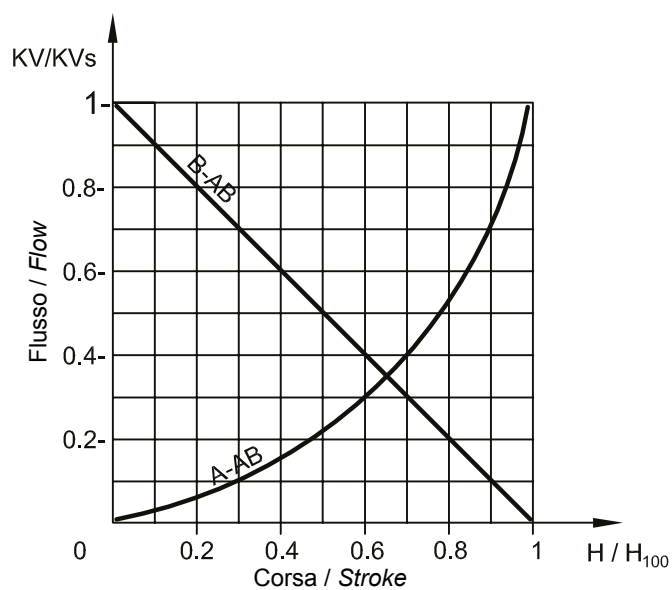

3-way

A-AB equal-percentage way
 B-AB bypass linear way
 3-way used as mixing inlet in A and B, outlet AB
 3-way used as diverting inlet in AB, outlet from A and B

AB way constant flow
A way variable flow
B (bypass) way variable flow

Dimensions and weights

Models	Thread	Dimensions (mm)			Weight kg
		A	B	C	
VGI215	G1/2	85	41	80	1.25
VGI315	G1/2	85	60	140	1.3
VGI220	G3/4	85	41	80	0.95
VGI320	G3/4	85	60	140	1
VGI225	G1	90	39	86	1.05
VGI325	G1	90	60	146	1.15
VGI232	G1 1/4	105	43	92	1.3
VGI332	G1 1/4	105	61	153	1.4
VGI240	G1 1/2	120	50.5	100	1.95
VGI340	G1 1/2	120	70.5	170.5	2.1
VGI250	G2	140	55.5	107	2.2
VGI350	G2	140	88.5	195.5	2.2

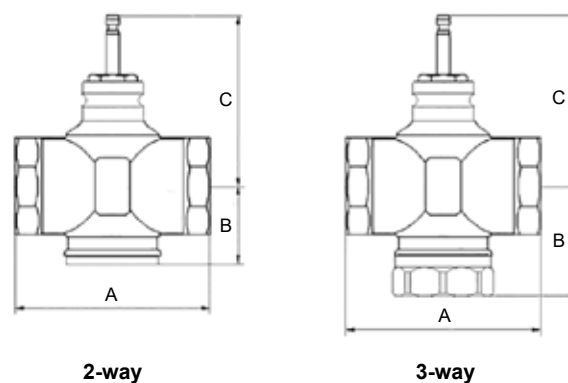



Description

The actuator series AVGI10 has been designed to control the screwed globe valves series VGI up to DN50. The actuator is equipped by a bidirectional synchronous motor at 1000 N and available in ON-OFF, floating, proportional and Modbus (RS485) version. Fast and easy assembly. The actuator is equipped, for the proportional version, with a button for self-adjustment.

Technical specifications

Power supply	See schedule
Electrical connection	Screw terminal
Torque	1000 N
Max. stroke	22 mm
Running time	See schedule
Materials	ABS cover, self-extinguishing, aluminum body
Protection degree	IP54
Protection class	III 24 V AC/DC, I 230 V AC, ±10%
Working range °C	0...+50°C
Storage temperature and humidity	-25...+50°C, 5...95% RH, non-condensing
Fluid temperature	< 130°C
Maintenance	Free



Models	Action	Supply	Consumption	Running time
AVGI10 AVGI10B	on-off, floating	24 V AC/DC 230 V AC, ±10%	5,5 VA	1,2 s/mm or 3 s/mm
AVGI10M AVGI10BM	proportional	24 V AC/DC 230 V AC, ±10%	7,5 VA	1,2 s/mm or 3 s/mm

Suffix: **S** for 2x SPDT microswitches (excluding modulating version)
MOD Only for proportional models. Actuators with RS485 (RTU) control also include built-in analog control capability. The control mode, either Modbus RS485 RTU or analog, can be selected via RS485 (RTU) communication commands. When RS485 control is active, the analog input is disabled, while the analog output remains functional.



Electrical wiring

1 - AVGI10M... proportional version

AVGI10M

(power supply 24 V AC/DC)

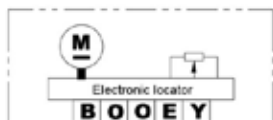

B	System potential 24 V	~ +
O	System neutral 0 V	~ -
O	Signal neutral (-)	~ -
E	Positioning signal (+)	⊕
Y	Position feedback (+)	⊕

Wiring: max. 1.5 mm²

AVGI10BM

(power supply 230 V AC)

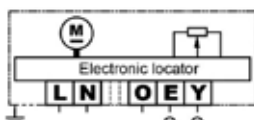

L	System potential 230 V	~ +
N	System neutral 0 V	~ -
O	Signal neutral (-)	~ -
E	Positioning signal (+)	⊕
Y	Position feedback (+)	⊕

Wiring: max. 1.5 mm²

AVGI10M/MOD, modbus RS485

(power supply 24 V AC/DC)

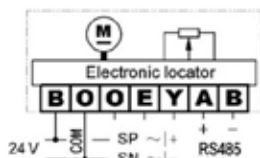

B	System potential 24 V	~ +
O	System neutral 0 V	~ -
O	Signal neutral (-)	~ -
E	Positioning signal (+)	⊕
Y	Position feedback (+)	⊕
A	485 Forward signal input (+)	⊕
B	485 Reverse signal input (-)	⊖

Wiring: max. 1.5 mm²

AVGI10BM/MOD, modbus RS485

(power supply 230 V AC)

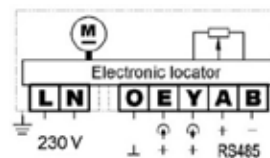

L	System potential 230 V	~ +
N	System neutral 0 V	~ -
O	Signal neutral (-)	~ -
E	Positioning signal (+)	⊕
Y	Position feedback (+)	⊕
A	485 Forward signal input (+)	⊕
B	485 Reverse signal input (-)	⊖

Wiring: max. 1.5 mm²

2 - AVGI10... on-off floating version

AVGI10

(power supply 24 V AC/DC)

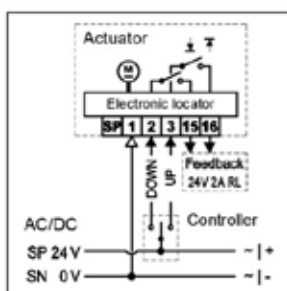

Optional: Connected as 3 wire

SP	System Potential 24 V AC/DC	
1	System Neutral 0 V AC/DC	
2	Stem extends	Power Supply 24 V AC/DC
3	Stem retracts	Power Supply 24 V AC/DC
15	Bottom limit	Output Power Supply Max. 3A
16	Top limit	Output Power Supply Max. 3A

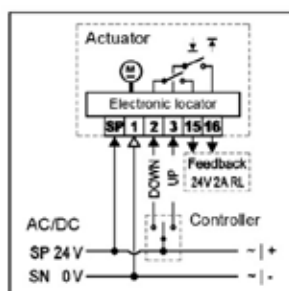

Optional: Connected as 4 wire

For Precise control and fast response in 3-point mode (0.02s)

Wiring: max. 1.5 mm²

AVGI10B

(power supply 230 V AC)

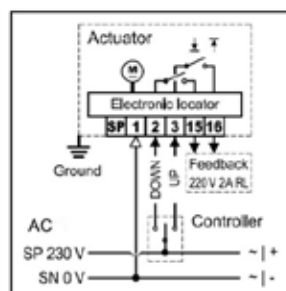

Optional: Connected as 3 wire

SP	System Potential 230 V AC	
1	System Neutral 0 V AC	
2	Stem extends	Power Supply 230 V AC
3	Stem retracts	Power Supply 230 V AC
15	Bottom limit	Output Power Supply Max. 3A
16	Top limit	Output Power Supply Max. 3A

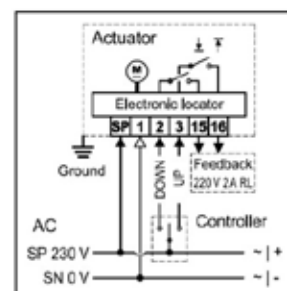

Optional: Connected as 4 wire

For Precise control and fast response in 3-point mode (0.02s)

Wiring: max. 1.5 mm²

Installation

As shown in the figure above, install the electric actuator onto the control valve body as follows:

Fig. 1 Using a suitable tool (pliers or a wrench), pull the valve stem out of the valve body to its highest position (1).

Fig. 2 Remove the U-bolt from the actuator and loosen the clamp on the actuator rod. Align the actuator rod with the valve stem (see Figure 2). Using a 5 mm Allen key, tighten the two screws securing the valve stem with a torque of 3.5–5.1 Nm (see Figure 3).

Fig. 3 Push the actuator downward until its bottom surface rests firmly on the valve body mounting surface (see Figure 4).

Fig. 4 As shown in Figures 5 and 6, insert the U-bolt into the mounting hole between the actuator and the valve body, then secure it with two M8 nuts (maximum torque: 16 Nm).

Fig. 5 Finally, slide the two indicator rings (one red and one blue) along the actuator bracket until they are positioned close to the pointer.

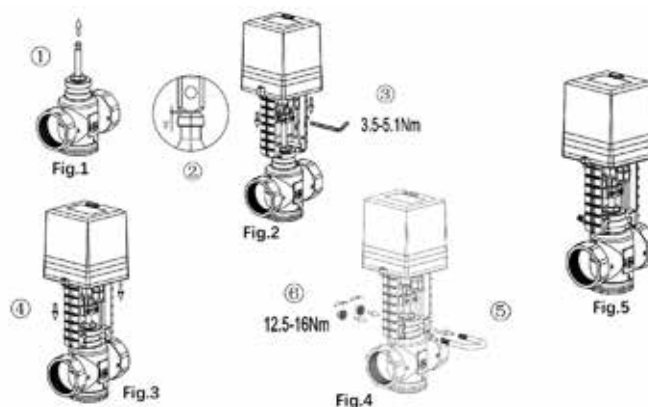



Setting AVGI10... ON/OFF, FLOATING

SW1 **DIP1:** FAST/SLOW – Speed selection
 FAST: AVGI10xx-1.2 s/mm
 SLOW: AVGI10xx-3 s/mm
DIP2: Undefined

The floating actuator is equipped with an electronic positioner, as shown in the figure beside:

1. Fully connect the actuator to the valve body

Install according to the diagram and the steps described in “Complete Machine Assembly”.

2. Correctly connect the power cable or control wiring

Perform wiring according to the “Wiring Diagram” included with the product.

3. Set the DIP switch to the required configuration

Adjust the DIP switch only after disconnecting the power supply.

4. Operate the actuator through the controller to perform a full run test

Once the test run is completed, the equipment commissioning is finished.

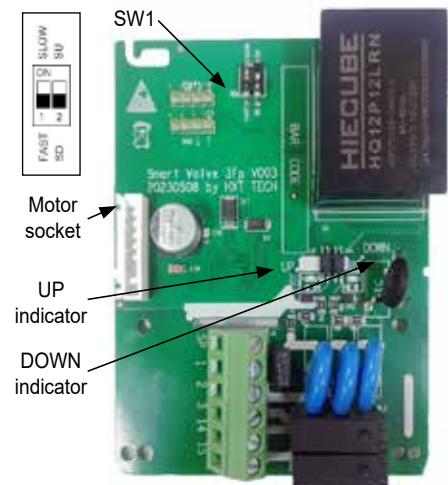

Setting AVGI10... PROPORTIONAL

DIP 1 – Feedback Signal Type

ON: DC current signal
OFF: DC voltage signal

DIP 2 – Input (Control) Signal Type

ON: DC current signal
OFF: DC voltage signal

DIP 3 – Positioner Action Mode (Direct / Reverse Acting)

OFF – Direct Acting: When the input signal increases, the actuator rod moves upward.

ON – Reverse Acting: When the input signal increases, the actuator rod moves downward.

DIP 4 & DIP 5 – Signal Loss Response Mode (Applicable only when the input signal is 4–20 mA or DC 2–10 V)

> When DIP 5 = OFF:

DIP 4 = ON: Upward fail-safe – on input signal loss, the actuator rod moves to the upper limit position.

DIP 4 = OFF: Downward fail-safe – on input signal loss, the actuator rod moves to the lower limit position.

> When DIP 5 = ON:

Position Hold – regardless of DIP 4, on input signal loss the actuator rod remains at its current position.

Note: This function is not available with DC 0–10 V or 0–20 mA input signals.

For these signal types, if the input signal is lost, the actuator defaults to operating according to the 0% signal level.

DIP 6 – Positioning Mode (Refer to the wiring diagram for system connections)

OFF: Modulating signal control mode

ON: 3-position control mode or manual control (manual operation possible using the mechanical handle)

DIP 7 – Starting Point of Input and Feedback Signals (0% / 20%)

OFF: 0% (e.g., DC 0–10 V, 0–20 mA)

ON: 20% (e.g., DC 2–10 V, 4–20 mA)

DIP 8 – Running Speed Selection

OFF: High-speed mode – 1.2 s/mm

ON: Low-speed mode – 3 s/mm

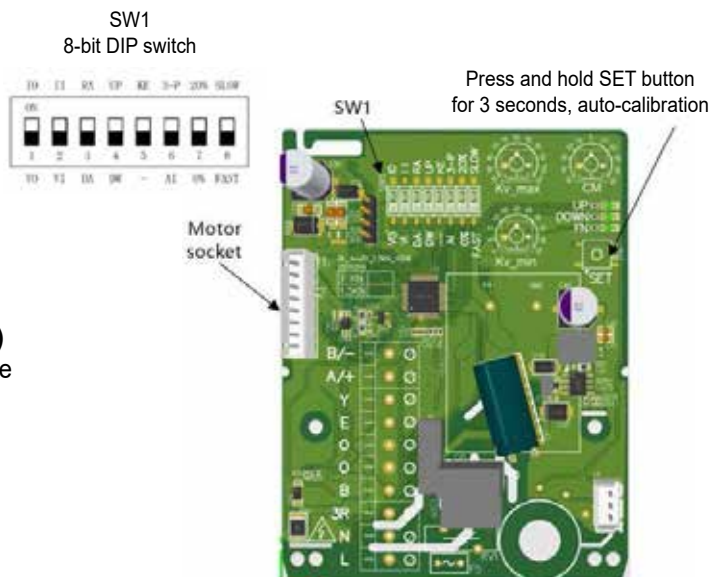



Content of the standard RS485 communication Modbus RTU protocol

1. Basic description of the agreement

No	Parameter name	Communication protocol stipulates
1	Working mode	Master-slave mode
2	baud rate	2400/4800/9600/19200 // Default: 9600
3	Byte format	No parity (default) / odd parity / even parity, 8-bit data bits, 1 stop bit
4	CRC check code	CRC-16 (Standard Modbus) 0x8005
5	CRC check method	CRC-16 (Standard Modbus)
6	Data frame interval	more than 3.5 bytes

2. Protocol format

2.1 Multiple register read - Function code: 0x03

Master to slave transmission format

Definition	Slave address	Function code	Starting address of the register		Register length		CRC16 checksum	
Bytes occupied	1	1	2		2		2	
Endianness	1	1	H	L	H	L	H	L

Device address (slave address): 0x01
Function code: 0x03 - Register reading

Starting register address: The starting address of the register to be read
Register length: The number of registers to be read

Slave to Master response format

Definition	Slave address	Function code	Num. of Bytes	The content of register 1		The content of register 2		The content of register N		CRC16 checksum	
Bytes occupied	1	1	1	2		2		2		2	
Endianness	1	1	1	H	L	H	L	H	L	H	L

Device address (slave address): 0x01
Function Code: 0x03 - Register Reading

Number of Bytes: Refers to the number of bytes contained in registers 1 to N
Contents of Registers 1 to N: The consecutive contents starting from the first address of the register and with a length equal to the register length N

2.2 Single Register Write - Function Code: 0x06

Master to slave transmission format

Definition	Slave address	Function code	Address of the register		The written content		CRC16 checksum	
Bytes occupied	1	1	2		2		2	
Endianness	1	1	H	L	H	L	H	L

Device address (slave address): 0x01
Function Code: 0x06 - Single Register Write

Register Address: Address of the register to be written
Register Content: Data content to be written

Slave to Master response format

Definition	Slave address	Function code	Address of the register		The written content		CRC16 checksum	
Bytes occupied	1	1	2		2		2	
Endianness	1	1	H	L	H	L	H	L

Device address (slave address): 0x01
Function Code: 0x06 - Single Register Write

Register Address: Address of the register to be written
Register Content: The written data content



2.3 Multiple register writing - Function code: 0x10

Master to slave transmission format

Definition	Slave address	Function code	Starting address of the register	Register length	Num. of Bytes	The content of register 1	The content of register 2	The content of register N	CRC16 checksum
Bytes occupied	1	1	2	2	1	2	2	2	2
Endianness	1	1	H L	H L	1	H L	H L	H L	H L

Device address (slave address): 0x01

Function Code: 0x10 - Multiple Register Write

Starting Register Address: The starting address of the register to be written

Register Length: The number of registers to be written

Number of Bytes: Refers to the number of bytes contained in registers 1 to N

Slave to Master response format

Definition	Slave address	Function code	Starting address of the register	Register length	CRC16 checksum
Bytes occupied	1	1	2	2	2
Endianness	1	1	H L	H L	H L

Slave address: 0x01

Function code: 0x10 - Multiple register write

Starting address of register: Starting address of the register to be written

Register length: Number of registers to be written

2.4 Custom function code: 0x45

-- Change communication address according to electronic serial number

Example of instructions:

Master to slave transmission format:

00 45 0beb ecf9 08 07 d3 // Set the slave address of the device with the electronic serial number 0x0BEB ECF0 (decimal 2 0001 1 001) to 0x08.

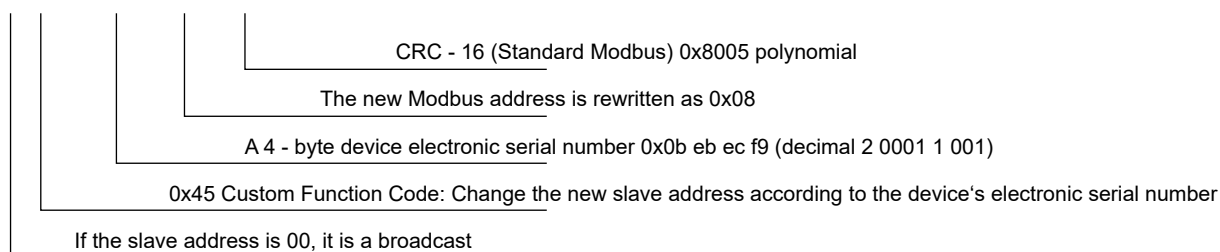

Slaves that meet the conditions update the address and reply to the information format:

08 45 0beb ecf9 08 8e 13 // The slave address of the device with the electronic serial number 0x0BEB ECF0 (decimal 2 0001 1 001) has been set to 0x08.

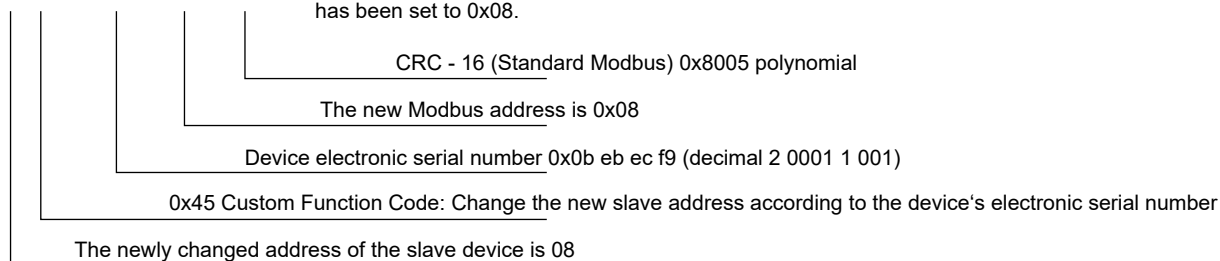



2.5 Custom function code: 0x41

-- Each slave device reports “electronic serial number + slave address” with a delay according to its electronic serial number

Example of instructions:

Master to slave transmission format:

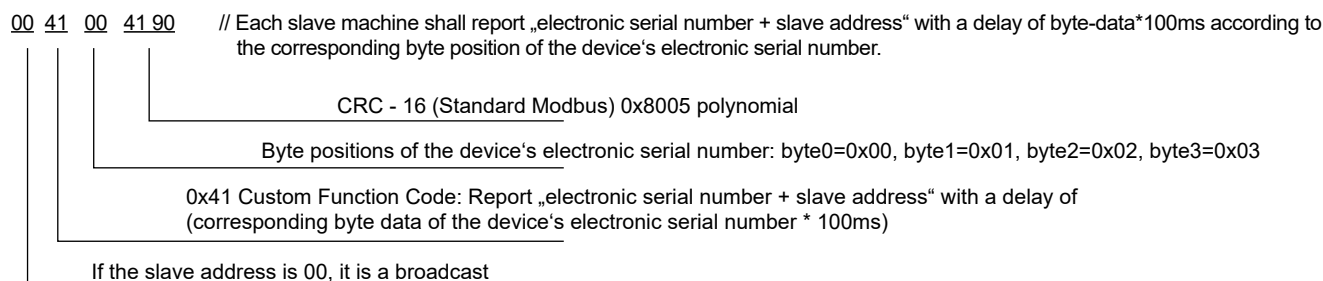

All slaves report “electronic serial number + slave address” with separate delayed reporting and reply to the information format:

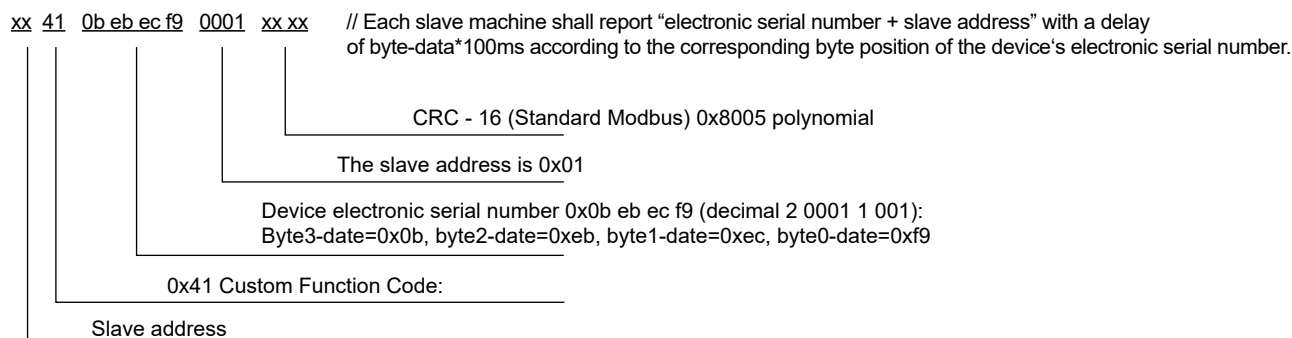

2. MODBUS-RTU Register Address Table

Read and write device configuration parameter information

Address	Function code	Register length	Variable name or meaning	Description	Remarks
0x0080	0x03/0x06	1	Communication configuration parameters	Bit15 Bit8 :0x00 (To be used) Bit7: 0 - 2 stop bits 1 - 1 stop bit (default) Bit6 - Bit5: 11 - odd parity 10 - even parity 01 - No verification (default) 00 - No verification Bit4 - Bit0: baud rate 00000 - 300bps 00001 - 600bps 00010 - 1200bps 00011 - 2400bps 00100 - 4800bps 00101 - 9600bps (default) 00110 - 19200bps 00111 - 115200bps	
0x0081 - 0 x 0082	0x03/0x06	2	Electronic Serial Number of this Device (Meter Number)	Factory default values, which users can modify by themselves. (Please note that the higher bits come first)	
0x0083	0x03/0x06	1	Slave address	Bit15-Bit8 :0x00 (To be used) Bit7-Bit0 : Slave address Default address 0x01, broadcast address 0x00, addresses can be set from 1 to 247	



Read device status information - a total of 3 registers

Address	Function code	Register length	Variable name or meaning	Description	Remarks
0x0208	0x03	1	Position feedback	0-1000 corresponds to 0-100.0%	
0x0209 - 0x020A	0x03	2	Fault code	Fault information is represented by bit status, where 0 indicates no fault and 1 indicates a fault. Except for the locked-rotor fault, other faults can only be cleared by powering on. Bit0: Upward locked-rotor (upward overload) Bit1: Downward locked-rotor (downward overload) Bit2: Upward stall alarm Bit3: Downward stall alarm Bit4: Upward fault alarm Bit5: Downward fault alarm Bit6: Potentiometer upper limit alarm Bit7: Potentiometer lower limit alarm Bit8: Signal loss alarm Bit9: Hardware failure Bit10: Self-calibration not completed Bit11: 0 Bit12: 0 Bit13: 0 Bit14: 0 Bit15: 0 Bit16: 0	

Example:

Reading device status information - Register start address: 0x0208, total of 3 (0x03) registers:

```
xx 03 0208 0003 xx // Command to read device status information
```

CRC - 16 (Standard Modbus) 0x8005 polynomial

Slave address: such as 0x01, etc. (hexadecimal number)

Write a valve opening command

Address	Function code	Register length	Variable name or meaning	Description	Remarks
0x01FF	0x06	1	Set the valve position	0-1000 corresponds to 0-100.0%	Opening control with immediate command given applicable to all working conditions.

Example:

Write a device opening command - Register address: 0x01FF:

```
xx 06 01FF 01F4 xx // Set the valve opening to 50% (50% -> decimal 500 -> hexadecimal 0x01F4)
```

CRC - 16 (Standard Modbus) 0x8005 polynomial

Slave address: such as 0x01, etc. (hexadecimal number)



Advanced Parameter Settings - Engineer Parameters

Address	Function code	Register length	Variable name or meaning	Description	Remarks
0x0404	0x06	1	Stroke self-calibration	Bit15-Bit1: reserved Bit0: Bit0=0 Disable Bit0=1 Enabled	
0x0405	0x06/0x03	1	Whether to enable the 485 function (not enabled by default)	0: Disable 1: Enabled	
0x0406	0x06	1	Input of the access password for the engineer parameter register	Default password 0x0531	When the password written in the instruction is the same as the default password, the engineering parameter writable mode will be activated. This mode remains active until a power outage occurs or a 2-hour timeout is reached.
0x0407-0x040F		9	Reserved		

■ Dimensions (mm)

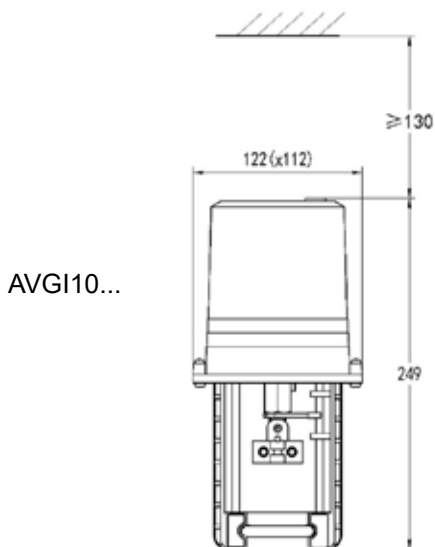



Description

The globe valves in brass serie VGO are used in heating, refrigeration and air-conditioning systems for the flow control of heated or chilled water for domestic and industrial applications. The valves are motorized by the electric actuators serie AVGO at 1500 N.

Technical specifications

Fluids type	Hot and cold water (with glycol max. 50%)
Fluid temperature	2...120°C
Nominal pressure	1600 kPa max (16 bar)
Control flow characteristics	Equal-percentage (linear on angle way)
Rangeability	50 : 1
Leakage	< 0,05% of KVs
Connections	BSP female thread
Stroke	22 mm
Installation position	Horizontal or vertical
Maintenance	Free
Body	Brass
Plug	Brass
Valve stem	Brass
Stem packing	PTFE
Dimensions and weight	See schedule



	Models		DN	KVs	Max diff. pressure (bar) (*)			Stroke mm	Actuator
	2 ways	3 ways			2 ways	3 ways (M)	3 ways (D)		
VGO265	VGO365		65	52	3.5	3.5	2	22	AVGO15(M)
VGO280	VGO380		80	80	2.5	2.5	2	22	AVGO15(M)

(*) The values in the brackets are the max. differential pressure when valve is fully closed and actuator is still able to open or close the valve with security. In order to avoid wear between plug and seat, we recommend not to overcome the nominal values.

Caution

Before valves are mounted, make sure that pipes are clean, free from welding slags, that are perfectly lined up with valve body and not subjected to vibrations. The valve can be mounted in any position except upside-down. While assembling, respect the flow directions indicated by the arrows located on the valve body.

In the 2-way valve, when stem is up, the direct way is open, with stem down direct way is closed.

In the 3-way valve, when stem is up, the direct way is closed, with stem down direct way is open.

VGO65-80



Installation

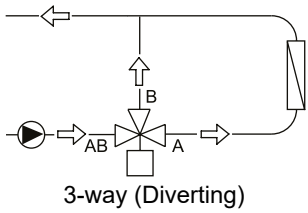
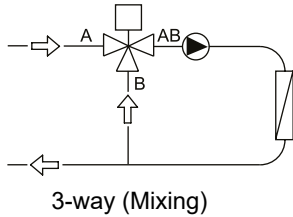
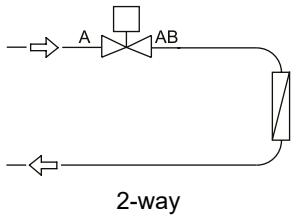

Control flow characteristics

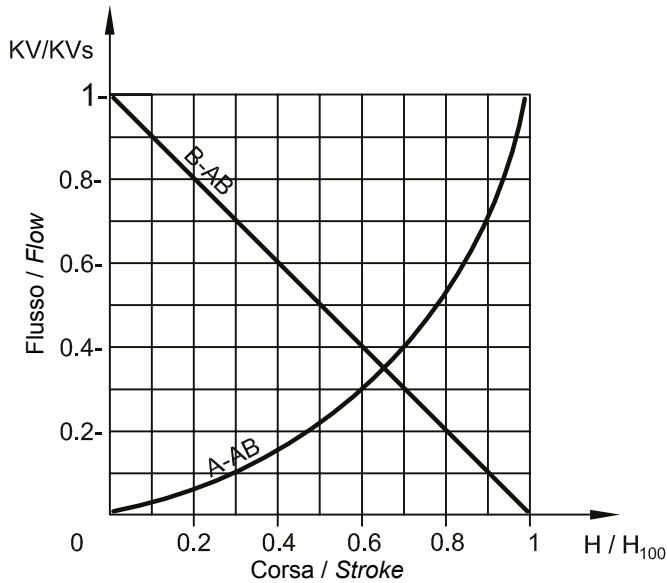

3-way

A-AB equal-percentage way
 B-AB bypass linear way
 3-way used as mixing inlet in A and B, outlet AB
 3-way used as diverting inlet in AB, outlet from A and B

AB way constant flow
A way variable flow
B (bypass) way variable flow

Dimensions and weights

Models	Thread	Dimensions (mm)			Weight kg
		A	B	C	
VGO265	G2 1/2	159	72	167	4.37
VGO365	G2 1/2	159	72	167	4.65
VGO280	G3	180	85	179.5	5.8
VGO380	G3	180	104	179.5	6.2

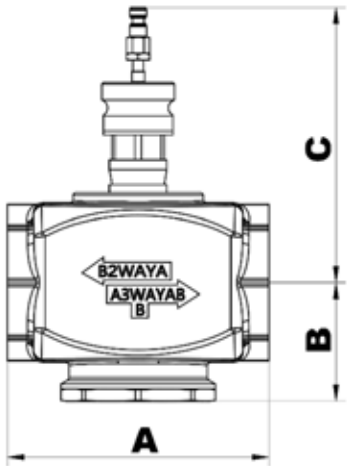



■ Description

The actuator series AVGO15 has been designed to control the screwed globe valves series VGI up to DN50. The actuator is equipped by a bidirectional synchronous motor at 1500 N and available in ON-OFF, floating, proportional and Modbus (RS485) version. Fast and easy assembly. The actuator is equipped, for the proportional version, with a button for self-adjustment.

■ Technical specifications

Power supply	See schedule
Electrical connection	Screw terminal
Torque	1500 N
Max. stroke	22 mm
Running time	See schedule
Materials	ABS cover, self-extinguishing, aluminum body
Protection degree	IP54
Protection class	III 24 V AC/DC, I 230 V AC, ±10%
Working range °C	0...+50°C
Storage temperature and humidity	-25...+50°C, 5...95% RH, non-condensing
Fluid temperature	< 130°C
Maintenance	Free



Models	Action	Supply	Consumption	Running time
AVGO15 AVGO15B	on-off, floating	24 V AC/DC 230 V AC, ±10%	5,5 VA	1,5 s/mm or 3,8 s/mm
AVGO15M AVGO15BM	proportional	24 V AC/DC 230 V AC, ±10%	7,5 VA	1,5 s/mm or 3,8 s/mm

Suffix: **S** for 2x SPDT microswitches (excluding modulating version)
MOD Only for proportional models. Actuators with RS485 (RTU) control also include built-in analog control capability. The control mode, either Modbus RS485 RTU or analog, can be selected via RS485 (RTU) communication commands. When RS485 control is active, the analog input is disabled, while the analog output remains functional.



Electrical wiring

1 - AVGO15M... proportional version

AVGO15M

(power supply 24 V AC/DC)

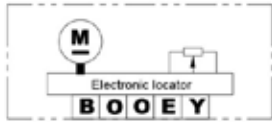

B	System potential 24 V	~ +
O	System neutral 0 V	~ -
O	Signal neutral (-)	~ -
E	Positioning signal (+)	⊥
Y	Position feedback (+)	⊥

Wiring: max. 1.5 mm²

AVGO15BM

(power supply 230 V AC)

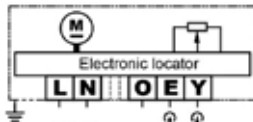

L	System potential 230 V	~ +
N	System neutral 0 V	~ -
O	Signal neutral (-)	~ -
E	Positioning signal (+)	⊥
Y	Position feedback (+)	⊥

Wiring: max. 1.5 mm²

AVGO15M/MOD, modbus RS485

(power supply 24 V AC/DC)

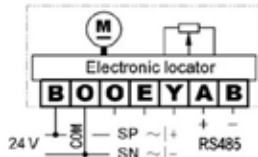

B	System potential 24 V	~ +
O	System neutral 0 V	~ -
O	Signal neutral (-)	~ -
E	Positioning signal (+)	⊥
Y	Position feedback (+)	⊥
A	485 Forward signal input (+)	⊥
B	485 Reverse signal input (-)	⊥

Wiring: max. 1.5 mm²

AVGO15BM/MOD, modbus RS485

(power supply 230 V AC)

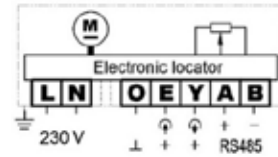

L	System potential 230 V	~ +
N	System neutral 0 V	~ -
O	Signal neutral (-)	~ -
E	Positioning signal (+)	⊥
Y	Position feedback (+)	⊥
A	485 Forward signal input (+)	⊥
B	485 Reverse signal input (-)	⊥

Wiring: max. 1.5 mm²

2 - AVGO15... on-off floating version

AVGO15

(power supply 24 V AC/DC)

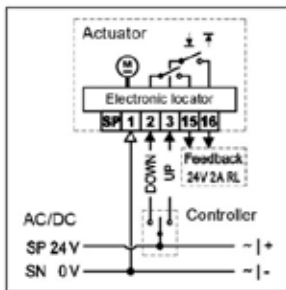

Optional: Connected as 3 wire

SP	System Potential 24 V AC/DC	
1	System Neutral 0 V AC/DC	
2	Stem extends	Power Supply 24 V AC/DC
3	Stem retracts	Power Supply 24 V AC/DC
15	Bottom limit	Output Power Supply Max. 3A
16	Top limit	Output Power Supply Max. 3A

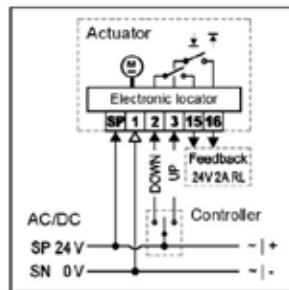

Optional: Connected as 4 wire

For Precise control and fast response in 3-point mode (0.02s)

Wiring: max. 1.5 mm²

AVGO15B

(power supply 230 V AC)

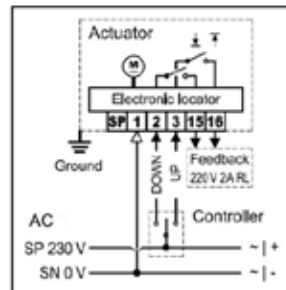

Optional: Connected as 3 wire

SP	System Potential 230 V AC	
1	System Neutral 0 V AC	
2	Stem extends	Power Supply 230 V AC
3	Stem retracts	Power Supply 230 V AC
15	Bottom limit	Output Power Supply Max. 3A
16	Top limit	Output Power Supply Max. 3A

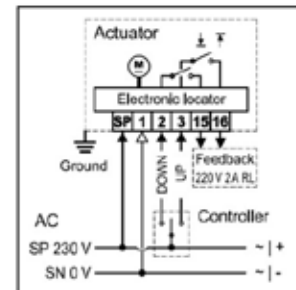

Optional: Connected as 4 wire

For Precise control and fast response in 3-point mode (0.02s)

Wiring: max. 1.5 mm²

Installation

As shown in the figure above, install the electric actuator onto the control valve body as follows:

Fig. 1 Using a suitable tool (pliers or a wrench), pull the valve stem out of the valve body to its highest position (1).

Fig. 2 Remove the U-bolt from the actuator and loosen the clamp on the actuator rod. Align the actuator rod with the valve stem (see Figure 2). Using a 5 mm Allen key, tighten the two screws securing the valve stem with a torque of 3.5–5.1 Nm (see Figure 3).

Fig. 3 Push the actuator downward until its bottom surface rests firmly on the valve body mounting surface (see Figure 4).

Fig. 4 As shown in Figures 5 and 6, insert the U-bolt into the mounting hole between the actuator and the valve body, then secure it with two M8 nuts (maximum torque: 16 Nm).

Fig. 5 Finally, slide the two indicator rings (one red and one blue) along the actuator bracket until they are positioned close to the pointer.

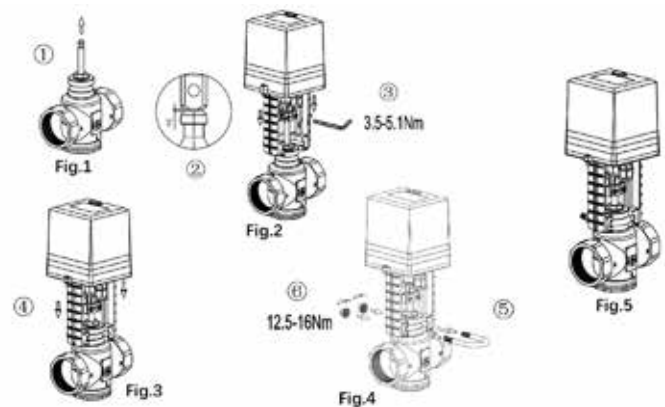



Setting AVGO15... ON/OFF, FLOATING

SW1 **DIP1:** FAST/SLOW – Speed selection
 FAST: AVGO15xx-1.5 s/mm
 SLOW: AVGO15xx-3,8 s/mm
DIP2: Undefined

The floating actuator is equipped with an electronic positioner, as shown in the figure beside:

1. Fully connect the actuator to the valve body

Install according to the diagram and the steps described in “Complete Machine Assembly”.

2. Correctly connect the power cable or control wiring

Perform wiring according to the “Wiring Diagram” included with the product.

3. Set the DIP switch to the required configuration

Adjust the DIP switch only after disconnecting the power supply.

4. Operate the actuator through the controller to perform a full run test

Once the test run is completed, the equipment commissioning is finished.

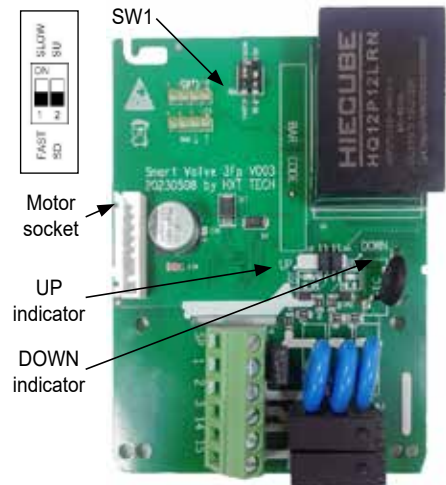

Setting AVGO15... PROPORTIONAL

DIP 1 – Feedback Signal Type

ON: DC current signal
OFF: DC voltage signal

DIP 2 – Input (Control) Signal Type

ON: DC current signal
OFF: DC voltage signal

DIP 3 – Positioner Action Mode (Direct / Reverse Acting)

OFF – Direct Acting: When the input signal increases, the actuator rod moves upward.

ON – Reverse Acting: When the input signal increases, the actuator rod moves downward.

DIP 4 & DIP 5 – Signal Loss Response Mode (Applicable only when the input signal is 4–20 mA or DC 2–10 V)

> When DIP 5 = OFF:

DIP 4 = ON: Upward fail-safe – on input signal loss, the actuator rod moves to the upper limit position.

DIP 4 = OFF: Downward fail-safe – on input signal loss, the actuator rod moves to the lower limit position.

> When DIP 5 = ON:

Position Hold – regardless of DIP 4, on input signal loss the actuator rod remains at its current position.

Note: This function is not available with DC 0–10 V or 0–20 mA input signals.

For these signal types, if the input signal is lost, the actuator defaults to operating according to the 0% signal level.

DIP 6 – Positioning Mode (Refer to the wiring diagram for system connections)

OFF: Modulating signal control mode

ON: 3-position control mode or manual control (manual operation possible using the mechanical handle)

DIP 7 – Starting Point of Input and Feedback Signals (0% / 20%)

OFF: 0% (e.g., DC 0–10 V, 0–20 mA)

ON: 20% (e.g., DC 2–10 V, 4–20 mA)

DIP 8 – Running Speed Selection

OFF: High-speed mode – 1.5 s/mm

ON: Low-speed mode – 3.8 s/mm

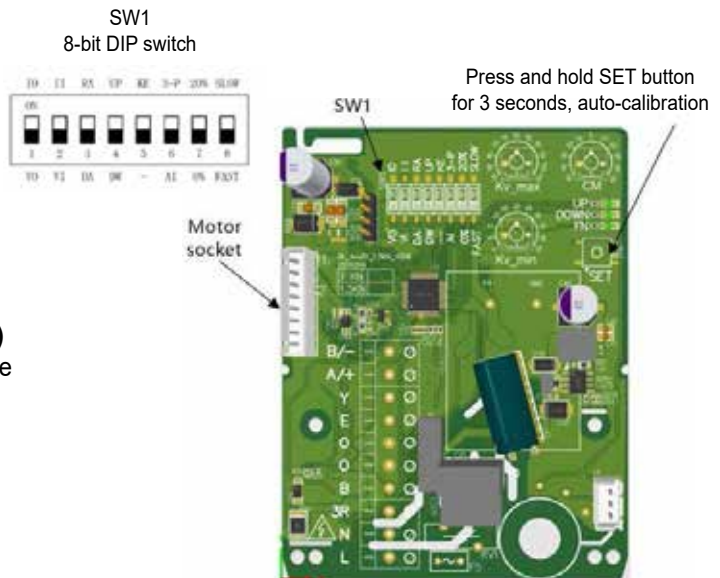



Content of the standard RS485 communication Modbus RTU protocol

1. Basic description of the agreement

No	Parameter name	Communication protocol stipulates
1	Working mode	Master-slave mode
2	baud rate	2400/4800/9600/19200 // Default: 9600
3	Byte format	No parity (default) / odd parity / even parity, 8-bit data bits, 1 stop bit
4	CRC check code	CRC-16 (Standard Modbus) 0x8005
5	CRC check method	CRC-16 (Standard Modbus)
6	Data frame interval	more than 3.5 bytes

2. Protocol format

2.1 Multiple register read - Function code: 0x03

Master to slave transmission format

Definition	Slave address	Function code	Starting address of the register		Register length		CRC16 checksum	
Bytes occupied	1	1	2		2		2	
Endianness	1	1	H	L	H	L	H	L

Device address (slave address): 0x01
Function code: 0x03 - Register reading

Starting register address: The starting address of the register to be read
Register length: The number of registers to be read

Slave to Master response format

Definition	Slave address	Function code	Num. of Bytes	The content of register 1		The content of register 2		The content of register N		CRC16 checksum	
Bytes occupied	1	1	1	2		2		2		2	
Endianness	1	1	1	H	L	H	L	H	L	H	L

Device address (slave address): 0x01
Function Code: 0x03 - Register Reading

Number of Bytes: Refers to the number of bytes contained in registers 1 to N
Contents of Registers 1 to N: The consecutive contents starting from the first address of the register and with a length equal to the register length N

2.2 Single Register Write - Function Code: 0x06

Master to slave transmission format

Definition	Slave address	Function code	Address of the register		The written content		CRC16 checksum	
Bytes occupied	1	1	2		2		2	
Endianness	1	1	H	L	H	L	H	L

Device address (slave address): 0x01
Function Code: 0x06 - Single Register Write

Register Address: Address of the register to be written
Register Content: Data content to be written

Slave to Master response format

Definition	Slave address	Function code	Address of the register		The written content		CRC16 checksum	
Bytes occupied	1	1	2		2		2	
Endianness	1	1	H	L	H	L	H	L

Device address (slave address): 0x01
Function Code: 0x06 - Single Register Write

Register Address: Address of the register to be written
Register Content: The written data content



2.3 Multiple register writing - Function code: 0x10

Master to slave transmission format

Definition	Slave address	Function code	Starting address of the register	Register length	Num. of Bytes	The content of register 1	The content of register 2	The content of register N	CRC16 checksum
Bytes occupied	1	1	2	2	1	2	2	2	2
Endianness	1	1	H L	H L	1	H L	H L	H L	H L

Device address (slave address): 0x01

Function Code: 0x10 - Multiple Register Write

Starting Register Address: The starting address of the register to be written

Register Length: The number of registers to be written

Number of Bytes: Refers to the number of bytes contained in registers 1 to N

Slave to Master response format

Definition	Slave address	Function code	Starting address of the register	Register length	CRC16 checksum
Bytes occupied	1	1	2	2	2
Endianness	1	1	H L	H L	H L

Slave address: 0x01

Function code: 0x10 - Multiple register write

Starting address of register: Starting address of the register to be written

Register length: Number of registers to be written

2.4 Custom function code: 0x45

-- Change communication address according to electronic serial number

Example of instructions:

Master to slave transmission format:

00 45 0beb ecf9 08 07 d3 // Set the slave address of the device with the electronic serial number 0x0BEB ECF0 (decimal 2 0001 1 001) to 0x08.

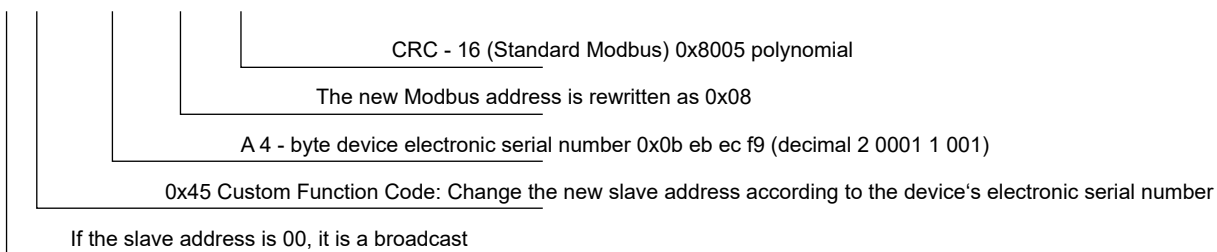

Slaves that meet the conditions update the address and reply to the information format:

08 45 0beb ecf9 08 8e 13 // The slave address of the device with the electronic serial number 0x0BEB ECF0 (decimal 2 0001 1 001) has been set to 0x08.

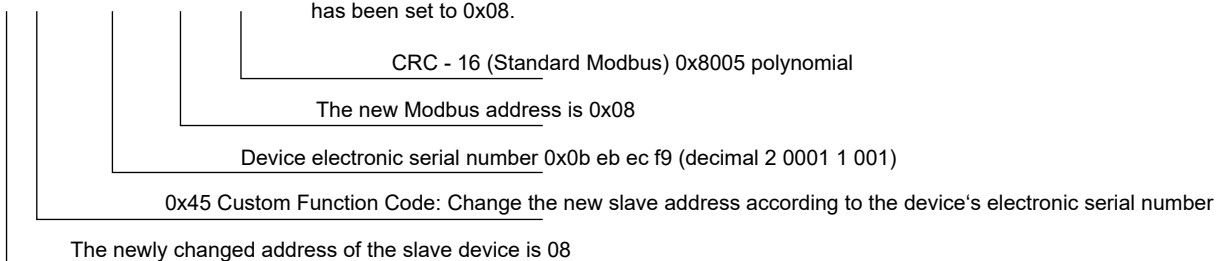



2.5 Custom function code: 0x41

-- Each slave device reports “electronic serial number + slave address” with a delay according to its electronic serial number

Example of instructions:

Master to slave transmission format:

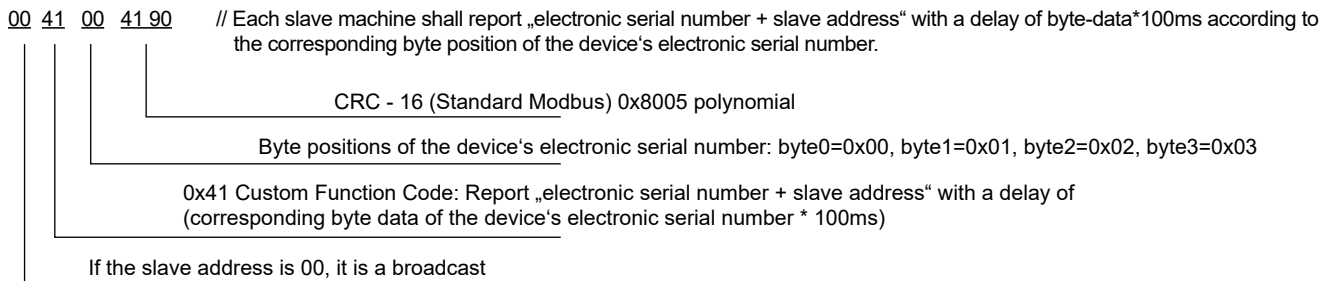

All slaves report “electronic serial number + slave address” with separate delayed reporting and reply to the information format:

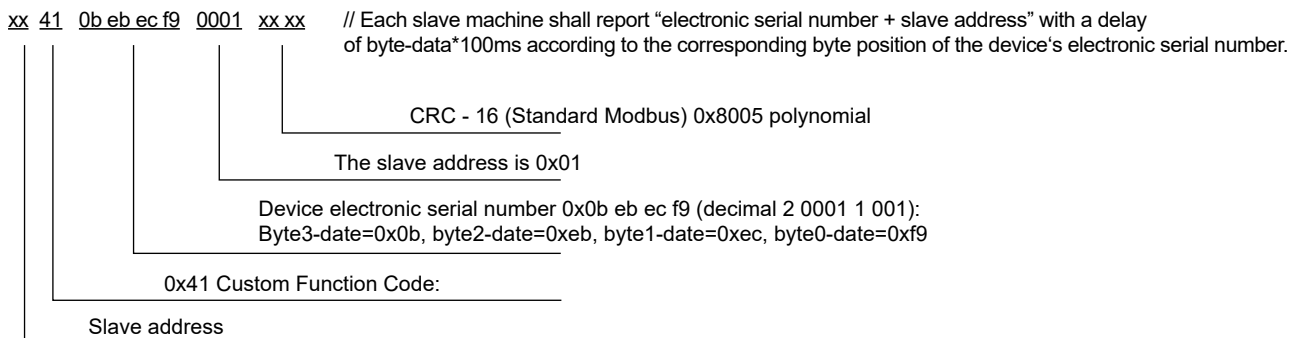

2. MODBUS-RTU Register Address Table

Read and write device configuration parameter information

Address	Function code	Register length	Variable name or meaning	Description	Remarks
0x0080	0x03/0x06	1	Communication configuration parameters	Bit15 Bit8 :0x00 (To be used) Bit7: 0 - 2 stop bits 1 - 1 stop bit (default) Bit6 - Bit5: 11 - odd parity 10 - even parity 01 - No verification (default) 00 - No verification Bit4 - Bit0: baud rate 00000 - 300bps 00001 - 600bps 00010 - 1200bps 00011 - 2400bps 00100 - 4800bps 00101 - 9600bps (default) 00110 - 19200bps 00111 - 115200bps	
0x0081 - 0 x 0082	0x03/0x06	2	Electronic Serial Number of this Device (Meter Number)	Factory default values, which users can modify by themselves. (Please note that the higher bits come first)	
0x0083	0x03/0x06	1	Slave address	Bit15-Bit8 :0x00 (To be used) Bit7-Bit0 : Slave address Default address 0x01, broadcast address 0x00, addresses can be set from 1 to 247	



Read device status information - a total of 3 registers

Address	Function code	Register length	Variable name or meaning	Description	Remarks
0x0208	0x03	1	Position feedback	0-1000 corresponds to 0-100.0%	
0x0209 - 0x020A	0x03	2	Fault code	Fault information is represented by bit status, where 0 indicates no fault and 1 indicates a fault. Except for the locked-rotor fault, other faults can only be cleared by powering on. Bit0: Upward locked-rotor (upward overload) Bit1: Downward locked-rotor (downward overload) Bit2: Upward stall alarm Bit3: Downward stall alarm Bit4: Upward fault alarm Bit5: Downward fault alarm Bit6: Potentiometer upper limit alarm Bit7: Potentiometer lower limit alarm Bit8: Signal loss alarm Bit9: Hardware failure Bit10: Self-calibration not completed Bit11: 0 Bit12: 0 Bit13: 0 Bit14: 0 Bit15: 0 Bit16: 0	

Example:

Reading device status information - Register start address: 0x0208, total of 3 (0x03) registers:

```
xx 03 0208 0003 xx // Command to read device status information
```

CRC - 16 (Standard Modbus) 0x8005 polynomial

Slave address: such as 0x01, etc. (hexadecimal number)

Write a valve opening command

Address	Function code	Register length	Variable name or meaning	Description	Remarks
0x01FF	0x06	1	Set the valve position	0-1000 corresponds to 0-100.0%	Opening control with immediate command given applicable to all working conditions.

Example:

Write a device opening command - Register address: 0x01FF:

```
xx 06 01FF 01F4 xx // Set the valve opening to 50% (50% -> decimal 500 -> hexadecimal 0x01F4)
```

CRC - 16 (Standard Modbus) 0x8005 polynomial

Slave address: such as 0x01, etc. (hexadecimal number)



Advanced Parameter Settings - Engineer Parameters

Address	Function code	Register length	Variable name or meaning	Description	Remarks
0x0404	0x06	1	Stroke self-calibration	Bit15-Bit1: reserved Bit0: Bit0=0 Disable Bit0=1 Enabled	
0x0405	0x06/0x03	1	Whether to enable the 485 function (not enabled by default)	0: Disable 1: Enabled	
0x0406	0x06	1	Input of the access password for the engineer parameter register	Default password 0x0531	When the password written in the instruction is the same as the default password, the engineering parameter writable mode will be activated. This mode remains active until a power outage occurs or a 2-hour timeout is reached.
0x0407-0x040F		9	Reserved		

■ Dimensions (mm)

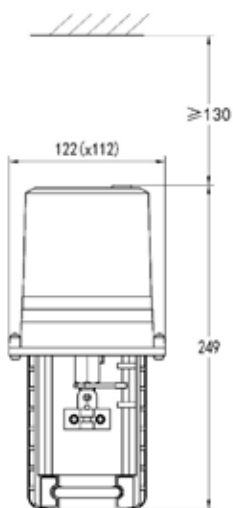

AVGO15...

Description



The globe valves in cast-iron serie VF are used in heating, refrigeration and air-conditioning systems for the flow control of heated or chilled water for domestic and industrial applications. The valves are motorized by the electric actuators serie AVF.

Technical specifications

Fluids type	Hot and cold water (with glycol max. 50%)
Fluid temperature	-10...120°C
Nominal pressure	1600 kPa max (16 bar)
Control flow characteristics	Equal-percentage on direct way Linear on angle way
Rangeability	50:1
Leakage	< 0,1% of KVs
Connections	Flange according EN1092-2
Stroke	See schedule
Installation position	Horizontal or vertical
Maintenance	Free
Body	Cast-iron G25
Plug	Brass
Valve stem	Stainless steel 302
Stem packing	PTFE
Dimensions and weight	See schedule



2 ways	Models		DN	KVs	Max differential pressure (bar) (*)	Stroke	Actuator
		3 ways					
VF250		VF350	50	50	2,5 (6)	20	AVF12(M)
VF265		VF365	65	75	2,0 (6)	20	AVF12(M)
VF280		VF380	80	100	1,5 (6)	20	AVF12(M)
VF2100		VF3100	100	125	1,5 (6)	38	AVF18(M)
VF2125		VF3125	125	200	2 (5)	38	AVF30(M)
VF2150		VF3150	150	285	2,0 (5)	38	AVF70(M)
VF2200		VF3200	200	400	1,5 (4)	38	AVF70(M)

(*) The values in the brackets are the max. differential pressure when valve is fully closed and actuator is still able to open or close the valve with security. In order to avoid wear between plug and seat, we recommend not to overcome the nominal values.

Caution

Before valves are mounted, make sure that pipes are clean, free from welding slags, that are perfectly lined up with valve body and not subjected to vibrations. The valve can be mounted in any position except upside-down. While assembling, respect the flow directions indicated by the arrows located on the valve body.

When stem is up, the direct way is closed, with stem down direct way is open.



Installation

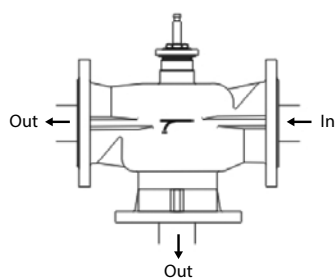

Diverting 3-way-valve

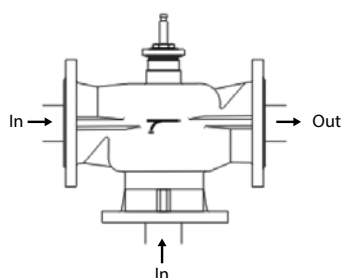

Mixing 3-way-valve

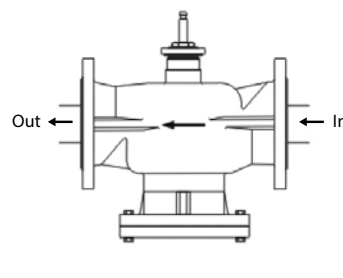

2-way-valve

Control flow characteristics

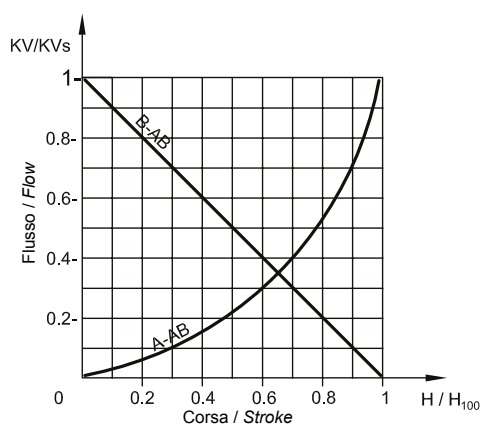

A-AB equal-percentage way
 B-AB bypass linear way
 3-way used as mixing inlet in A and B, outlet AB
 3-way used as diverting inlet in AB, outlet from A and B

AB way constant flow
A way variable flow
B (bypass) way variable flow

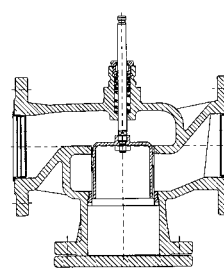

2 ways

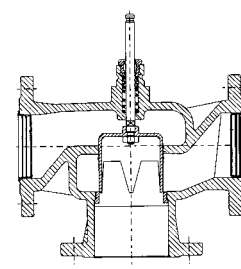

3 ways

Dimensions and weights

Models	Thread		Dimensions (mm)				Weight kg
	DN	D	d	L	A	B	
VF250	50	165	125	230	133	166	14
VF350	50	165	125	230	115	166	11,8
VF265	65	185	145	290	164	178	19,7
VF365	65	185	145	290	145	178	16,4
VF280	80	200	160	310	177	182	23,2
VF380	80	200	160	310	155	182	20,4
VF2100	100	220	180	350	200	264	39,5
VF3100	100	220	180	350	175	264	33,7
VF2125	125	250	210	400	228	275	54,5
VF3125	125	250	210	400	200	275	46
VF2150	150	285	240	480	268	290	76,3
VF3150	150	285	240	480	240	290	65
VF2200	200	340	290	600	330	315	135
VF3200	200	340	290	600	300	315	120

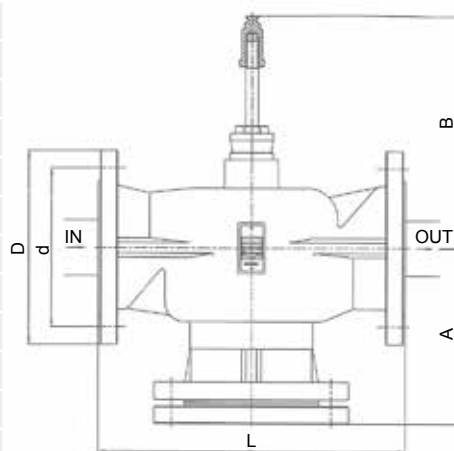

Actuator for flanged globe valve

Description

The actuator series AVF has been designed to control the flanged globe valves serie VF. The actuator is equipped by a double bidirectional synchronous motor at 1200 and 1800 N and available in ON-OFF, floating and proportional version. Fast and easy assembly. The actuator is fitted with manual override for the drive in case of power failure.

Technical specifications

Power supply	24 V AC 50/60 Hz, 12 VA
Electrical connection	Screw terminal
Torque	See schedule
Max. stroke	See schedule
Running time	See schedule
Materials	ABS cover, self-extinguishing Aluminium bracket
Protection degree	IP54
Protection class	II
Working range °C	-10...+50°C
Storage temperature and humidity	-40...+50°C, 1...95% RH, non-condensing
Fluid temperature	< 150°C
Maintenance	Free



Models	Torque N	Action	Stroke mm	Running time
AVF12	1200	on-off, floating	20	114 sec. with 50 Hz 95 sec: with 60 Hz
AVF12M	1200	proportional	20	114 sec. with 50 Hz 95 sec: with 60 Hz
AVF18	1800	on-off, floating	40	210 sec. with 50 Hz 175 sec: with 60 Hz
AVF18M	1800	proportional	40	210 sec. with 50 Hz 175 sec: with 60 Hz

Electrical wiring

AVF..M (proportional)

Terminal J1:

02: When short-circuiting with T2 (o -), then the stem goes completely up (direct way close). The position of W3 has no effect.

01: When short-circuiting with T2 (o -), then the stem goes completely down (direct way open). The position of W3 has no effect.

T1 T2: input terminal at 24 V AC. T2 is common terminal (T2 is connected with -).

- +: Input signal 4...20 mA (2...10 V DC) / 0...20 mA (0...10 V DC). W2 and W4 must be set according to the input signal.

F: Feedback signal. There is a signal 0...10 V DC or 2...10 V DC depending on the setting of W2.

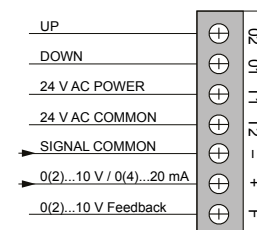

AVF.. (on-off, floating)

1: 24 V AC Stem down (direct way open)

4: Feedback with stem down (24 V AC)

5: 24 V AC (common)

6: 24 V AC Stem up (direct way close)

7: Feedback with stem up (24 V AC)

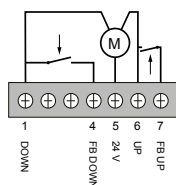



Installation

Place motor on the valve and, having placed in seat, tighten the 4 locking screw (1).

Push the steel plate (2) and raise the valve stem or, alternatively, drive down the actuator shaft by manual override (3).

Make the electrical connections as shown in the previous diagrams and (only for AVF..M) provide for the jumper settings. (3).

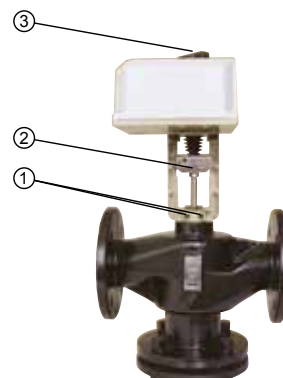

Setting (AVF..M)

W1: 0%, 50%, 100%. Set the position of valve stroke in case of malfunction or failure of input signal.

0% stem completely up **50%** stem at halfway **100%** stem completely down
Moving the jumper W3, the situation is reversed.

0% stem completely down **50%** stem at halfway **100%** stem completely up

W2: 4...20 mA (2...10 V DC) / 0...20 mA (0...10 V DC). This jumper must be set according to W4 to select the input signal to J1.

W3: Reverse operation. Moving the jumper inverts the logic of operation as compared to the input signal.

W4: mA / V DC. This jumper must be set according to W2 to select the input signal to J1.

LED Status Indicator (work): Normal operating status: flashing slowly (1 sec on, one sec off). During the self-adaptation of the actuator on the valve (after pressing S1 for at least 3 sec) flashes rapidly (0.25 sec on, 0.25 sec off).

Self-adjustment in an error state: blinks twice quickly and off for a long time (on 0.25 sec, off for 0.25 sec, twice, then off by 1.25 sec).

LED indication of the rotation direction of the motor:

When the LED **D60** lights up, the valve rod moves downward. When the valve rod reaches the bottom and hold the position for 25 seconds, the LED turns off.

When the LED **D50** lights up, the valve rod moves upward. When the valve rod reaches the top and hold the position for 25 seconds, the LED turns off.

Self-adjustment of the actuator to the valve. Each actuator must be adapted to the valve to which it is coupled.

Press and hold the "**S1**" key for 3 sec, the actuator automatically will enter the self-adjustment. The LED "work" is flashing rapidly (on 0.25 sec., off 0.25 sec.). The valve shaft moves down to the bottom, and then maintains the position for 25 sec and then move upward until the upper point. The self-adjustment does not end until the valve shaft does not hold the final position for 25 sec.

To self-adaptation occurred (the previous data is overwritten), the actuator returns to normal operation. Otherwise (the previous data is not overwritten), will be reported the failure of the state of self-adjustment (on 0.25 sec., off 0.25 sec., twice, then off by 1.25 sec.). You can hold down the "S1" key for 3 sec to retry the process of self-adjustment, or reboot (power cycle) of the actuator to return to normal working state.

Possible errors of self-adjustment:

1: It occurs in the case where the stroke is reached less than half the nominal stroke.

2: The connection of the potentiometer is wrong (terminal J2). Correct way: when the valve shaft is downward the potentiometer has the maximum value, when the valve shaft is upward the potentiometer has the minimum value.

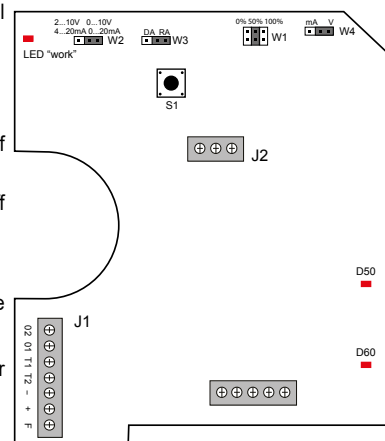

Dimensions (mm)

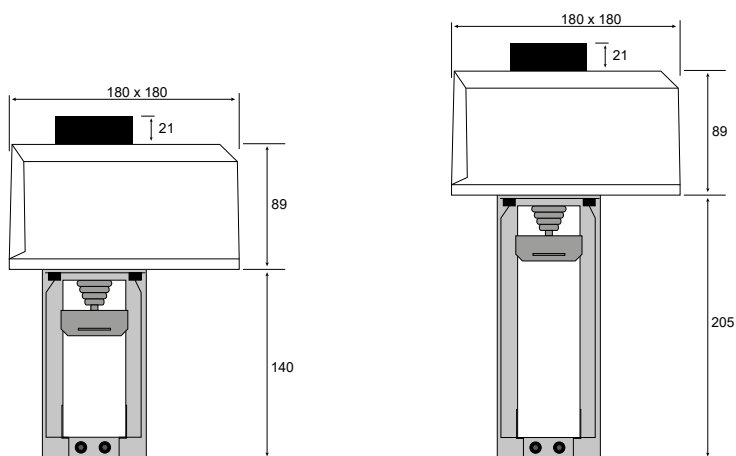

Description

The actuator series AVF30 has been designed to control the flanged globe valves serie VF, size DN125. The actuator is equipped by a double bidirectional synchronous motor at 3000 N and available in ON-OFF, floating and proportional version. Fast and easy assembly. The actuator is fitted with manual override for the drive in case of power failure.

Technical specifications

Power supply	24 V AC $\pm 10\%$, 50/60 Hz, 12 VA
Electrical connection	Screw terminal
Torque	3000 N
Max. stroke	40 mm
Running time	See schedule
Materials	ABS cover, self-extinguishing Aluminium bracket
Protection degree	IP54
Protection class	II
Working range °C	-10...+50°C
Storage temperature and humidity	-40...+50°C, 1...95% RH, non-condensing
Fluid temperature	< 150°C
Maintenance	Free



Models	Action	Stroke mm	Running time
AVF30	on-off, floating	40	105 sec. with 50 Hz 90 sec: with 60 Hz
AVF30M	proportional		

Electrical wiring

AVF30M (proportional)

Terminal J1:

UP: When short-circuiting with COM, then the stem goes completely up (direct way close).
The position of W3 has no effect.

DOWN: When short-circuiting with COM, then the stem goes completely down (direct way open).
The position of W3 has no effect.

24V, COM: Input terminal at 24 V AC. COM is common terminal. The COM terminals are internally connected.

IN, COM: Input signal 4...20 mA (2...10 V DC) / 0...20 mA (0...10 V DC).

FB: Feedback signal. There is a signal 0...10 V DC or 2...10 V DC

AVF30 (on-off, floating)

1: 24 V AC Stem down (direct way open)

4: Feedback with stem down (24 V AC)

5: 24 V AC (common)

6: 24 V AC Stem up (direct way close)

7: Feedback with stem up (24 V AC)

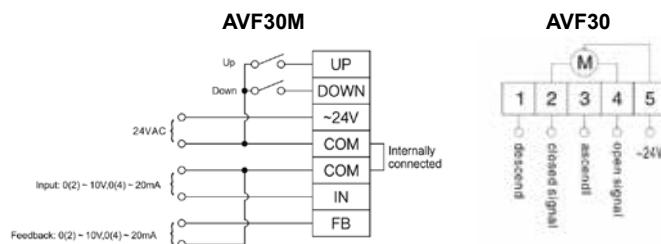

Dimensions (mm)

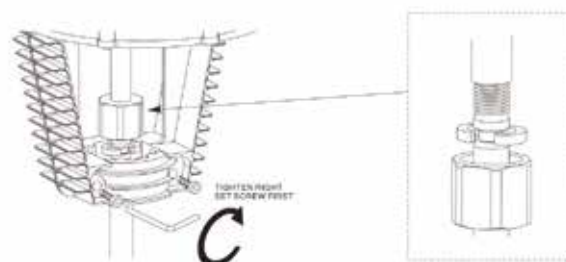
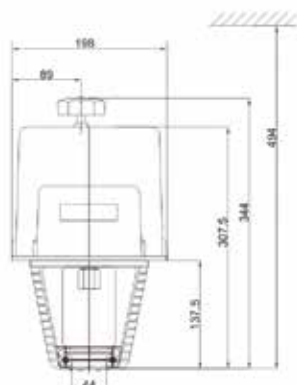



Installation

Set the actuator into neck of the body top.

Lock the two semi-rings into the groove above the stem top. Pull up the nut and connect it to the thread under the actuator.

Tighten the bolt up with 4 mm inside hexagonal wrench.

Note: tighten the right side bolt.

Ensure the stem is fastened and the connection is finished.

Setting (AVF..M)

W1: 0%, 50%, 100%. Set the position of valve stroke in case of malfunction or failure of input signal. The factory default setting is 50%.

0% stem completely up **50%** stem at halfway **100%** stem completely down

Moving the jumper W3, the situation is reversed.

0% stem completely down **50%** stem at halfway **100%** stem completely up

W2: 4...20 mA (2...10 V DC) / 0...20 mA (0...10 V DC). This jumper must be set according to W4 to select the input signal to J1.

W3: Reverse operation. Moving the jumper inverts the logic of operation as compared to the input signal.

W4: mA / V DC. This jumper must be set according to W2 to select the input signal to J1.

LED Status Indicator (work): Normal operating status: flashing slowly (1 sec on, one sec off). During the self-adaptation of the actuator on the valve (after pressing S1 for at least 3 sec) flashes rapidly (0.25 sec on, 0.25 sec off).

Self-adjustment in an error state: blinks twice quickly and off for a long time (on 0.25 sec, off for 0.25 sec, twice, then off by 1.25 sec).

LED indication of the rotation direction of the motor:

When the LED **D60** lights up, the valve rod moves downward. When the valve rod reaches the bottom and hold the position for 25 seconds, the LED turns off.

When the LED **D50** lights up, the valve rod moves upward. When the valve rod reaches the top and hold the position for 25 seconds, the LED turns off.

Self-adjustment of the actuator to the valve. Each actuator must be adapted to the valve to which it is coupled.

Press and hold the "**S1**" key for 3 sec, the actuator automatically will enter the self-adjustment. The LED "work" is flashing rapidly (on 0.25 sec., off 0.25 sec.). The valve shaft moves down to the bottom, and then maintains the position for 25 sec and then move upward until the upper point. The self-adjustment does not end until the valve shaft does not hold the final position for 25 sec.

To self-adaptation occurred (the previous data is overwritten), the actuator returns to normal operation. Otherwise (the previous data is not overwritten), will be reported the failure of the state of self-adjustment (on 0.25 sec., off 0.25 sec., twice, then off by 1.25 sec.). You can hold down the "S1" key for 3 sec to retry the process of self-adjustment, or reboot (power cycle) of the actuator to return to normal working state.

Possible errors of self-adjustment:

1: It occurs in the case where the stroke is reached less than half the nominal stroke.

2: The connection of the potentiometer is wrong (terminal J2). Correct way: when the valve shaft is downward the potentiometer has the maximum value, when the valve shaft is upward the potentiometer has the minimum value.

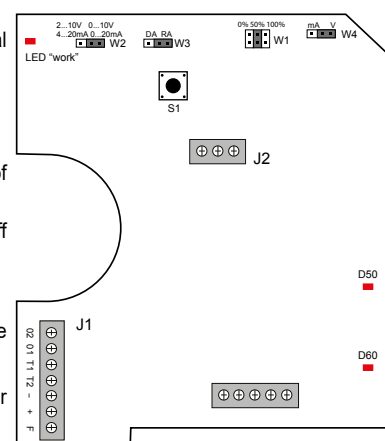



Description

The actuator series AVF70 has been designed to control the flanged globe valves serie VF, size DN150 and DN200. The actuator is equipped by a double bidirectional synchronous motor at 7000 N and available in ON-OFF, floating and proportional version. Fast and easy assembly. The actuator is fitted with manual override for the drive in case of power failure.

Technical specifications

Power supply	24 V AC $\pm 10\%$, 50/60 Hz, 12 VA
Electrical connection	Screw terminal
Torque	7000 N
Max. stroke	38 mm
Running time	See schedule
Materials	ABS cover, self-extinguishing Aluminium bracket
Protection degree	IP54
Protection class	II
Working range °C	-10...+50°C
Storage temperature and humidity	-40...+50°C, 1...95% RH, non-condensing
Fluid temperature	< 150°C
Maintenance	Free



Models	Action	Stroke mm	Running time
AVF70	on-off, floating	38	240 sec. with 50 Hz 175 sec: with 60 Hz
AVF70M	proportional		

Electrical wiring

AVF70M (proportional)

Terminal J1:

- 02:** When short-circuiting with T2 (o -), then the stem goes completely up (direct way close). The position of W3 has no effect.
- 01:** When short-circuiting with T2 (o -), then the stem goes completely down (direct way open). The position of W3 has no effect.

T1 T2: input terminal at 24 V AC. T2 is common terminal (T2 is connected with -).

- +: Input signal 4...20 mA (2...10 V DC) / 0...20 mA (0...10 V DC).

F: Feedback signal. There is a signal 0...10 V DC or 2...10 V DC

AVF70 (on-off, floating)

- 1:** 24 V AC Stem down (direct way open)
- 4:** Feedback with stem down (24 V AC)
- 5:** 24 V AC (common)
- 6:** 24 V AC Stem up (direct way close)
- 7:** Feedback with stem up (24 V AC)

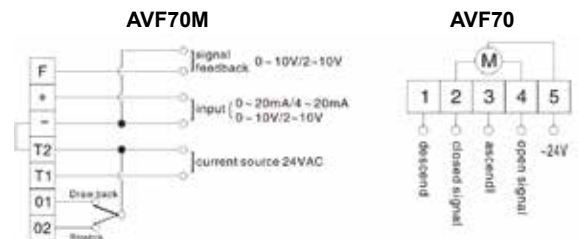

Dimensions (mm)

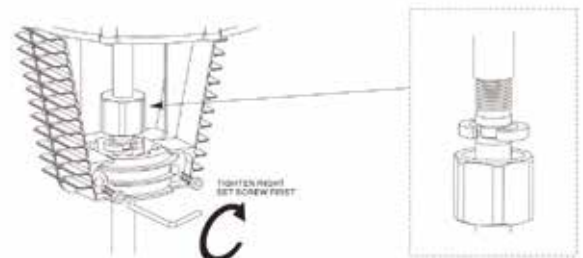
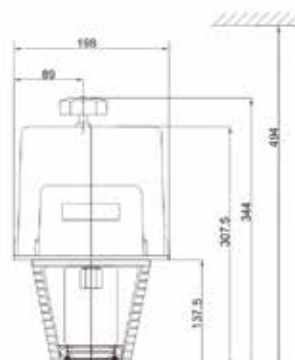



Installation

Set the actuator into neck of the body top.

Lock the two semi-rings into the groove above the stem top. Pull up the nut and connect it to the thread under the actuator.

Tighten the bolt up with 4 mm inside hexagonal wrench.

Note: tighten the right side bolt.

Ensure the stem is fastened and the connection is finished.

Setting (AVF..M)

W1: 0%, 50%, 100%. Set the position of valve stroke in case of malfunction or failure of input signal. The factory default setting is 50%.

0% stem completely up **50%** stem at halfway **100%** stem completely down

Moving the jumper W3, the situation is reversed.

0% stem completely down **50%** stem at halfway **100%** stem completely up

W2: 4...20 mA (2...10 V DC) / 0...20 mA (0...10 V DC). This jumper must be set according to W4 to select the input signal to J1.

W3: Reverse operation. Moving the jumper inverts the logic of operation as compared to the input signal.

W4: mA / V DC. This jumper must be set according to W2 to select the input signal to J1.

LED Status Indicator (work): Normal operating status: flashing slowly (1 sec on, one sec off). During the self-adaptation of the actuator on the valve (after pressing S1 for at least 3 sec) flashes rapidly (0.25 sec on, 0.25 sec off).

Self-adjustment in an error state: blinks twice quickly and off for a long time (on 0.25 sec, off for 0.25 sec, twice, then off by 1.25 sec).

LED indication of the rotation direction of the motor:

When the LED **D60** lights up, the valve rod moves downward. When the valve rod reaches the bottom and hold the position for 25 seconds, the LED turns off.

When the LED **D50** lights up, the valve rod moves upward. When the valve rod reaches the top and hold the position for 25 seconds, the LED turns off.

Self-adjustment of the actuator to the valve. Each actuator must be adapted to the valve to which it is coupled.

Press and hold the "**S1**" key for 3 sec, the actuator automatically will enter the self-adjustment. The LED "work" is flashing rapidly (on 0.25 sec., off 0.25 sec.). The valve shaft moves down to the bottom, and then maintains the position for 25 sec and then move upward until the upper point. The self-adjustment does not end until the valve shaft does not hold the final position for 25 sec.

To self-adaptation occurred (the previous data is overwritten), the actuator returns to normal operation. Otherwise (the previous data is not overwritten), will be reported the failure of the state of self-adjustment (on 0.25 sec., off 0.25 sec., twice, then off by 1.25 sec.). You can hold down the "S1" key for 3 sec to retry the process of self-adjustment, or reboot (power cycle) of the actuator to return to normal working state.

Possible errors of self-adjustment:

1: It occurs in the case where the stroke is reached less than half the nominal stroke.

2: The connection of the potentiometer is wrong (terminal J2). Correct way: when the valve shaft is downward the potentiometer has the maximum value, when the valve shaft is upward the potentiometer has the minimum value.

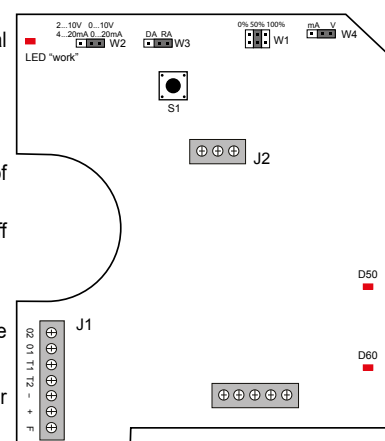



Description

The VFF series cast iron valves are used to control the flow of hot or cold water in heating, air conditioning or refrigeration systems in civil and industrial plants. They are motorised with AVFF series actuators.

Technical specifications

Fluid	Hot and cold water (with max. 50% glycol)
Fluid temperature	-25...130°C
Nominal pressure	1600 kPa max (16 bar)
Regulation characteristics	Direct equipercentage path Linear angle path
Regulation capacity	100:1
Leakage	< 0,5 % of KVs
Pipe connection	Flange according EN1092-2
Stroke	See table
Installation position	Horizontal or vertical
Maintenance	Free
Body	QT450 cast iron
Shutter and valve stem	Aisi 304 steel
Seals	PTFE+EPDM
Dimensions and weight	See schedule



2 way	Model	3 way	DN	KVs	Max pres. diff. (bar) *			Stroke D	Actuators
					2 way	3 way (M)	3 way (D)		
VFF250		VFF350	50	40	4	4	2	19	AVFF15...
VFF265		VFF365	65	52	3,5	3,5	2	20	AVFF15...
VFF280		VFF380	80	88	2,5	2,5	2	20	AVFF15...
VFF2100		VFF3100	100	125	3,5	3,5	1,5	40	AVFF30...
VFF2125		VFF3125	125	220	8	2	1	40	AVFF30...
VFF2150		VFF3150	150	300	8	1,2	0,7	40	AVFF30...
VFF2200		VFF3200	200	420	8	0,7	0,7	40	AVFF30...

Warnings

Before installing the valves, ensure that the pipes are clean, free of welding slag, perfectly aligned with the valve body and not subject to vibrations. The valve can be installed in any position except upside down. When installing, observe the flow directions indicated by the arrows on the valve body.

With the stem extended (up), the direct path is closed; with the stem retracted (down), the direct path is open.



Installation

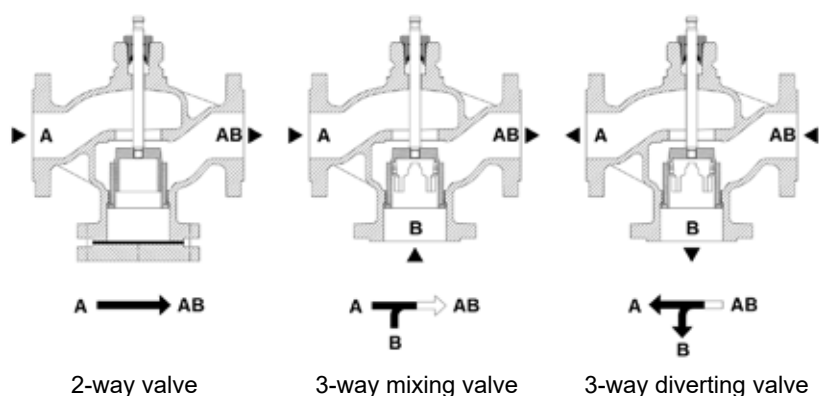

Flow control characteristic

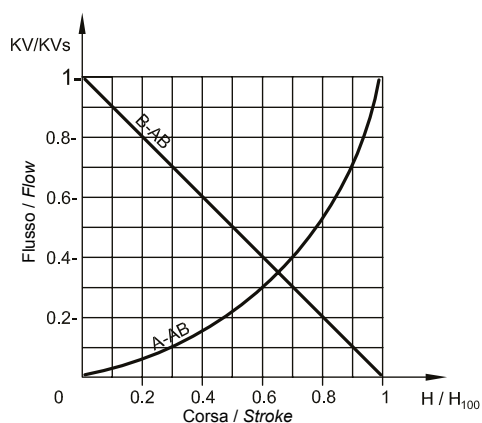

Port A-AB equal-percentage
 Bypass B-AB linear
 Used as mixing valve
 flow from A and B, outlet to AB
 Used as diverting valve
 flow from AB, outlet to A and B
Port AB constant flow
Port A variable flow
Port B (bypass) variable flow

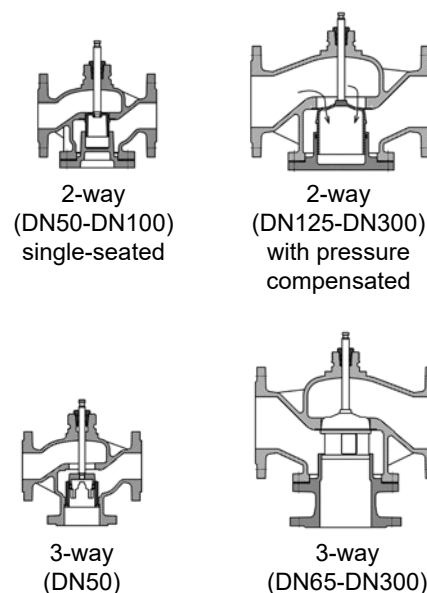

Dimensions and weights

Model	Connection		Dimension (mm)					Weight
	DN	L	D	K	H5	H2	h	kg
VFF250	50	230	165	125	63	115	66	12
VFF350								9,7
VFF265								15
VFF365	65	290	180	145	77	183	66	18
VFF280								19,5
VFF380								24
VFF2100	100	350	215	180	99	203	66	25
VFF3100								30,5
VFF2125								39,5
VFF3125	125	400	245	210	119	236	66	44
VFF2150								52,5
VFF3150								65
VFF2200	200	495	340	295	145	307	66	87,5
VFF3200								95

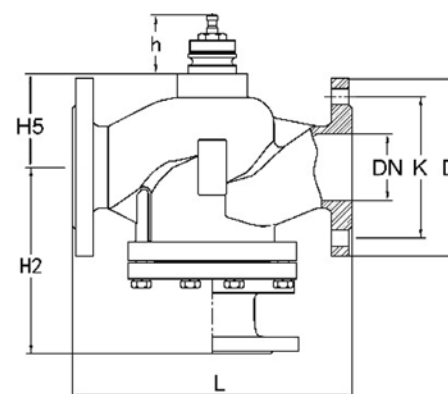



Description

The AVFF actuator series has been designed to control the flanged globe valves of the VFF series and is available in ON-OFF, floating, proportional and Modbus RS485 (RTU) control versions. The 1500 N actuator is equipped with a high-efficiency brushless DC motor, while the 3000 N actuator is equipped with a bidirectional synchronous motor. Fast and easy assembly. All AVFF actuators are fitted with a manual override for manual operation in the event of power failure.

Technical specifications

Power supply	see schedule
Electrical connection	screw terminal
Torque	see schedule
Max. stroke	see schedule
Running time	see schedule
Materials	ABS cover, self-extinguishing aluminium bracket
Protection degree	IP54
Protection class	III 24 V AC/DC, I 230 V AC, ±10%
Working range °C	-10...+55°C
Storage temperature and humidity	-15...+55°C, 1...95% RH, non-condensing
Fluid temperature	< 130°C
Maintenance	free



Model	Torque N	Action	Stroke mm	Power supply	Consump. VA	DN	Running time s/mm
AVFF15 AVFF15B	1500	on-off	22	24 V AC/DC 230V AC	12	50-80	1,5 or 3,8
AVFF15M AVFF15BM	1500	proportional	22	24 V AC/DC 230V AC	12	50-80	1,5 or 3,8
AVFF30 AVFF30B	3000	on-off	50	24 V AC/DC 230 V AC 50/60 Hz	18	100-200	3,1 (50 Hz)
AVFF30M AVFF30BM	3000	proportional	50	24 V AC/DC 230 V AC 50/60 Hz	20	100-200	3,1 (50 Hz)

Suffix: **S** for 2x SPDT microswitches (excluding modulating version)
MOD Only for proportional models. Actuators with RS485 (RTU) control also include built-in analog control capability. The control mode, either Modbus RS485 RTU or analog, can be selected via RS485 (RTU) communication commands. When RS485 control is active, the analog input is disabled, while the analog output remains functional.



Electrical wiring

1 - AVFF15M... proportional version

AVFF15M

(power supply 24 V AC/DC)

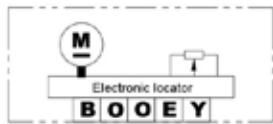

B	System potential 24 V	~ +
O	System neutral 0 V	~ -
O	Signal neutral (-)	~ + -
E	Positioning signal (+)	⊕
Y	Position feedback (+)	⊕

Wiring: max. 1.5 mm²

AVFF15BM

(power supply 230 V AC)

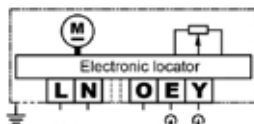

L	System potential 230 V	~ +
N	System neutral 0 V	~ -
O	Signal neutral (-)	~ + -
E	Positioning signal (+)	⊕
Y	Position feedback (+)	⊕

Wiring: max. 1.5 mm²

AVFF15M/MOD, modbus RS485

(power supply 24 V AC/DC)

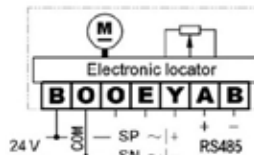

B	System potential 24 V	~ +
O	System neutral 0 V	~ -
O	Signal neutral (-)	~ + -
E	Positioning signal (+)	⊕
Y	Position feedback (+)	⊕
A	485 Forward signal input (+)	⊕
B	485 Reverse signal input (-)	⊖

Wiring: max. 1.5 mm²

AVFF15BM/MOD, modbus RS485

(power supply 230 V AC)

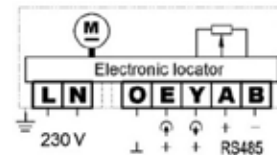

L	System potential 230 V	~ +
N	System neutral 0 V	~ -
O	Signal neutral (-)	~ + -
E	Positioning signal (+)	⊕
Y	Position feedback (+)	⊕
A	485 Forward signal input (+)	⊕
B	485 Reverse signal input (-)	⊖

Wiring: max. 1.5 mm²

2 - AVFF15... on-off floating version

AVFF15

(power supply 24 V AC/DC)

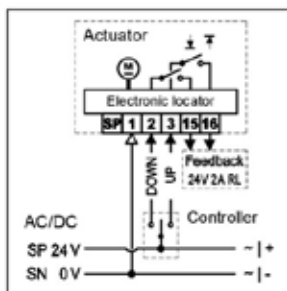

Optional: Connected as 3 wire

SP	System Potential 24 V AC/DC
1	System Neutral 0 V AC/DC
2	Stem extends ↓ Power Supply 24 V AC/DC
3	Stem retracts ↑ Power Supply 24 V AC/DC
15	Bottom limit Output Power Supply Max. 3 A
16	Top limit Output Power Supply Max. 3 A

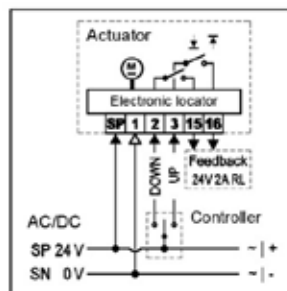

Optional: Connected as 4 wire

For Precise control and fast response in 3-point mode (0.02s)

Wiring: max. 1.5 mm²

AVFF15B

(power supply 230 V AC)

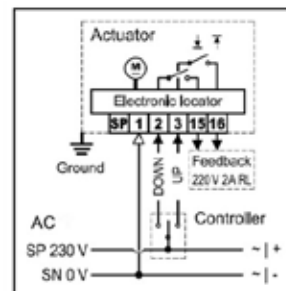

Optional: Connected as 3 wire

SP	System Potential 230 V AC
1	System Neutral 0 V AC
2	Stem extends ↓ Power Supply 230 V AC
3	Stem retracts ↑ Power Supply 230 V AC
15	Bottom limit Output Power Supply Max. 3 A
16	Top limit Output Power Supply Max. 3 A

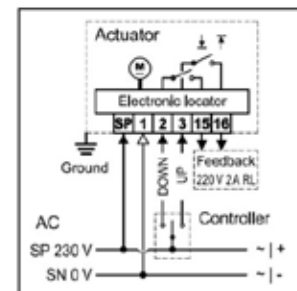

Optional: Connected as 4 wire

For Precise control and fast response in 3-point mode (0.02s)

Wiring: max. 1.5 mm²

3 - AVFF30M... proportional version

AVFF30M

(power supply 24 V AC)

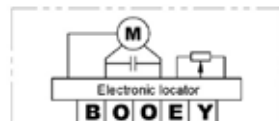

B	System potential 24 V AC	~
O	System neutral 0 V AC	~
O	Signal neutral (-)	~ + -
E	Positioning signal (+)	⊕
Y	Position feedback (+)	⊕

Wiring: max. 1.5 mm²

AVFF30BM

(power supply 230 V AC)

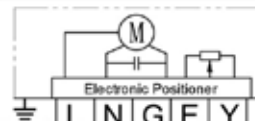

L	Power supply 230 V AC	~
N	Power neutral 0 V AC	~
G	Signal neutral (-)	~ + -
E	Input 0-10V or 4-20 mA (+)	⊕
Y	Output 0-10V or 4-20 mA (+)	⊕

Wiring: max. 1.5 mm²

AVFF30M/MOD, modbus RS485

(power supply 24 V AC)

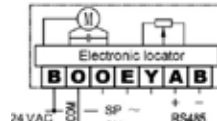

B	System potential 24 V	~
O	System neutral 0 V	~
O	Signal neutral (-)	~ + -
E	Positioning signal (+)	⊕
Y	Position feedback (+)	⊕
A	485 Forward signal input (+)	⊕
B	485 Reverse signal input (-)	⊖

Wiring: max. 1.5 mm²

AVFF30M/MOD, modbus RS485

(power supply 230 V AC)



L	System potential 230 V	~
N	System neutral 0 V	~
G	Signal neutral (-)	~ + -
E	Positioning signal (+)	⊕
Y	Position feedback (+)	⊕
A	485 Forward signal input (+)	⊕
B	485 Reverse signal input (-)	⊖

Wiring: max. 1.5 mm²



4 - AVFF30... on-off floating version

AVFF30

(power supply 24 V AC)

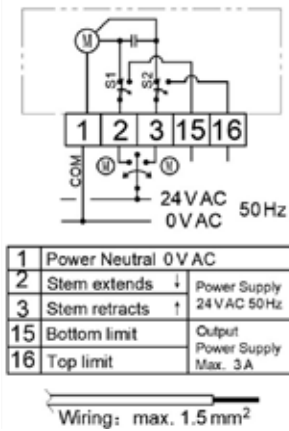

AVFF30B

(power supply 230 V AC)

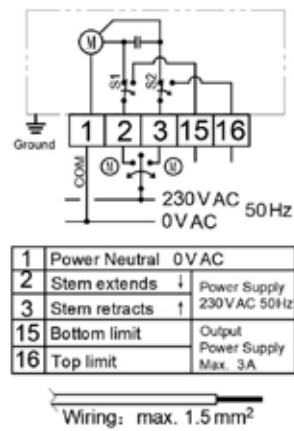

Installation

As shown in the steps in the figure beside, install the electric actuator onto the control valve body:

Fig.1: First, use a tool (pliers or a wrench) to pull the valve stem of the control valve out of the valve body to its highest position (1).

Fig.2: Remove the U-bolt from the actuator and loosen the clamp on the actuator rod. Align the actuator rod with the valve stem and push them down together until the bottom surface of the actuator rests on the valve body mounting plane (2).

Fig. 3: Connect the actuator rod to the valve stem (3). Before assembly, ensure that the actuator rod and the valve stem are tightly butted against each other with no gaps. Using a 5 mm hex key, pre-connect the clamp clips, but do not fully tighten the screws yet.

Note: The clamp clips of AVFF15.. and AVFF30.. differ slightly. For AVFF30.., ensure the clamp is oriented so that the direction of the clamp relative to the notch aligns correctly with the side of the actuator rod.

Insert the U-bolt into the mounting hole between the actuator and the valve body, and tighten it using two M8 nuts (max torque = 16 Nm) (4).

Fig. 4: Tighten the two clamp screws with a 5 mm hex wrench, applying a maximum torque of 8 Nm (5).

Fig. 5: Finally, slide the two pointer rings (one red, one blue) along the actuator bracket until they are close to the pointer position.

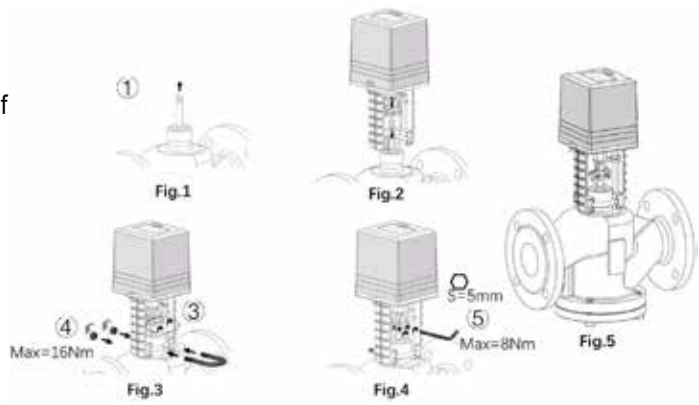

Setting AVFF15... ON/OFF, FLOATING

The floating actuator is equipped with an electronic positioner, as shown in the figure beside:

1. Fully connect the actuator to the valve body

Install according to the diagram and the steps described in "Complete Machine Assembly".

2. Correctly connect the power cable or control wiring

Perform wiring according to the "Wiring Diagram" included with the product.

3. Set the DIP switch to the required configuration

Adjust the DIP switch only after disconnecting the power supply.

4. Operate the actuator through the controller to perform a full run test

Once the test run is completed, the equipment commissioning is finished.

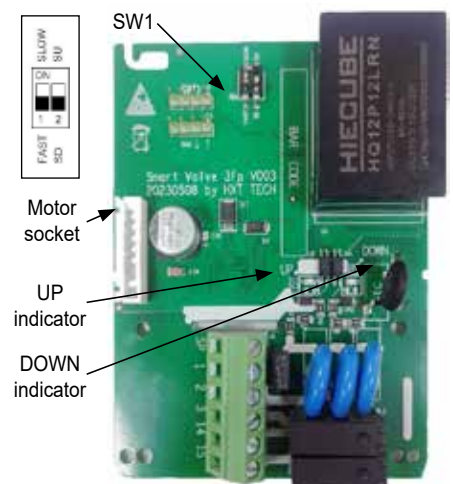

Setting AVFF15... PROPORTIONAL

DIP 1 – Feedback Signal Type

- ON:** DC current signal
- OFF:** DC voltage signal

DIP 2 – Input (Control) Signal Type

- ON:** DC current signal
- OFF:** DC voltage signal

DIP 3 – Positioner Action Mode (Direct / Reverse Acting)

- OFF – Direct Acting:** When the input signal increases, the actuator rod moves upward.
- ON – Reverse Acting:** When the input signal increases, the actuator rod moves downward.

DIP 4 & DIP 5 – Signal Loss Response Mode (Applicable only when the input signal is DC 4–20 mA or DC 2–10 V)

> When DIP 5 = OFF:

- DIP 4 = ON:** Upward fail-safe – on input signal loss, the actuator rod moves to the upper limit position.
- DIP 4 = OFF:** Downward fail-safe – on input signal loss, the actuator rod moves to the lower limit position.

> When DIP 5 = ON:

- Position Hold** – regardless of DIP 4, on input signal loss the actuator rod remains at its current position.
- Note: This function is not available with DC 0–10 V or DC 0–20 mA input signals.
- For these signal types, if the input signal is lost, the actuator defaults to operating according to the 0% signal level.

DIP 6 – Positioning Mode (Refer to the wiring diagram for system connections)

- OFF:** Modulating signal control mode
- ON:** 3-position control mode or manual control (manual operation possible using the mechanical handle)

DIP 7 – Starting Point of Input and Feedback Signals (0% / 20%)

- OFF:** 0% (e.g., DC 0–10 V, DC 0–20 mA)
- ON:** 20% (e.g., DC 2–10 V, DC 4–20 mA)

DIP 8 – Running Speed Selection

- OFF:** High-speed mode – 1.5 s/mm
- ON:** Low-speed mode – 3.8 s/mm

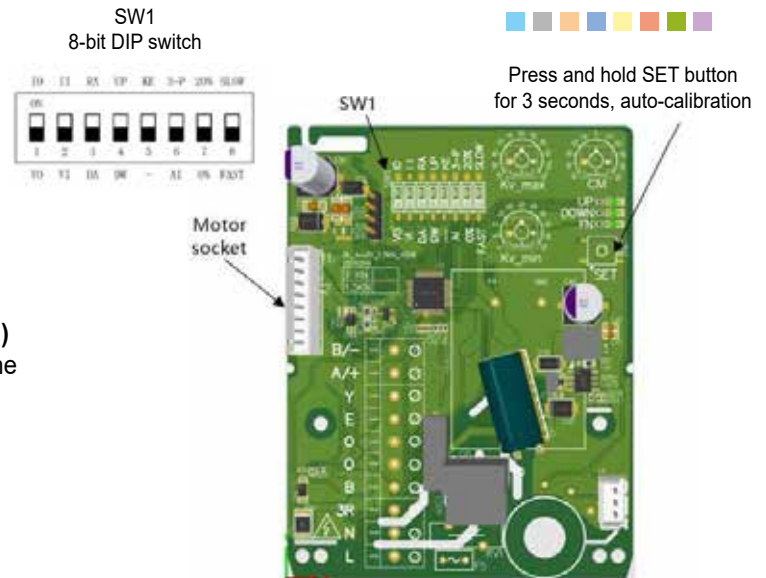

Setting AVFF30M... PROPORTIONAL 24 V AC

The proportional actuator is equipped with an electronic positioner, as shown above:

1. Connect the actuator to the valve body

Install according to the diagram and the steps described in “Complete Assembly”.

2. Perform correct wiring

Follow the “Wiring Diagram” provided inside the product.

3. Set the DIP switches to the required configuration

Refer to “Positioner Setting” below; make all adjustments with the power disconnected.

4. Turn on the actuator power supply

All three indicators will illuminate simultaneously and then turn off, indicating that the positioner self-test is complete.

5. Start the auto-calibration procedure

Press and hold the **SET** button for more than 3 seconds to initiate the full auto-calibration sequence:

- > The actuator rod first moves **downward**: During downward movement, the **SET** and **UP** indicators flash, while the **DOWN** indicator remains steadily lit. Once the rod reaches the valve’s lower end position and the position is recorded, it begins to move upward.
- > The actuator rod then moves **upward**: During upward movement, the **SET** and **DOWN** indicators flash while the **UP** indicator remains steadily lit. After reaching the valve’s upper end position and recording it, all indicators stop flashing and turn off.

Auto-calibration is now complete, and the system returns to the normal control state.

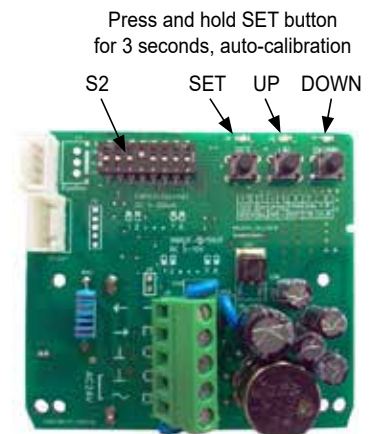



Switch S2 – DIP Function Overview (Compact Table)

DIP 1 – Feedback Signal Type

- ON: Current (DC mA)
- OFF: Voltage (DC V)

DIP 2 – Input (Control) Signal Type

- ON: Current (DC mA)
- OFF: Voltage (DC V) Use together with DIP 7 and DIP 8.

DIP 3 – Action Mode

- OFF: Direct acting (signal ↑ → rod up)
- ON: Reverse acting (signal ↑ → rod down)

DIP 4 & DIP 5 – Signal Loss Response

- (For 0–10 V / 2–10 V / 4–20 mA)
- DIP 5 OFF + DIP 4 ON: Fail-safe Up (rod → upper limit)
- DIP 5 OFF + DIP 4 OFF: Fail-safe Down (rod → lower limit)
- DIP 5 ON: Position Hold (rod stays in place)
- Note: Not functional for 0–20 mA (defaults to 0 mA behavior).

DIP 6 – Manual / Auto Mode

- OFF: Auto (follows input signal)
- ON: Manual (operate via handle or UP/DOWN buttons)

DIP 7 – Signal Start Point

- OFF: 0% (0–10 V, 0–20 mA)
- ON: 20% (2–10 V, 4–20 mA)

DIP 8 – Signal Resistance Matching

- ON: Current input matching
- OFF: Voltage input matching

S2

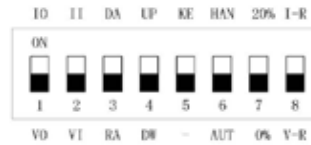

S2	Setting status														
	Output signal		Input signal		Positioner Action modes		Signal loss response			Manual/ Auto selection		Starting point		Resistance matching	
	Voltage	Current	Voltage	Current	Direct Acting	Reverse acting	Down	Up	Position hold	Auto	Manual	0%	20%	Voltage signal	Current signal
	VO	IO	VI	II	DA	RA	DW	UP	KE	AUT	HAN	0%	20%	V-R	I-R
1	OFF	ON													
2			OFF	ON											
3					OFF	ON									
4							OFF	ON	-						
5							OFF	OFF	ON						
6										OFF	ON				
7												OFF	ON		
8														OFF	ON

Standard signal
DIP switch status
Setting map

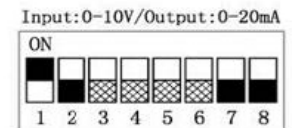
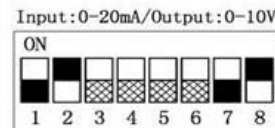
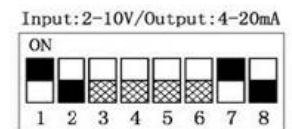
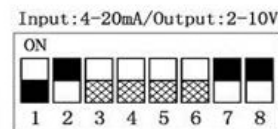
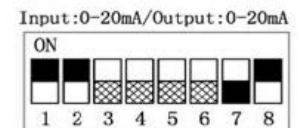
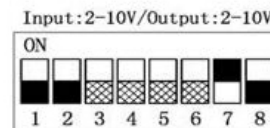
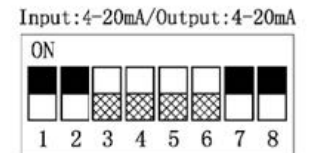
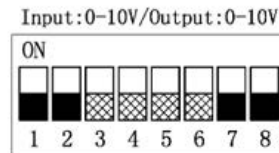



Proportional 230 V AC (AVFF...B)

Instructions for the actuator panel with an electronic locator

Press and hold SET button for 3 seconds, auto-calibration

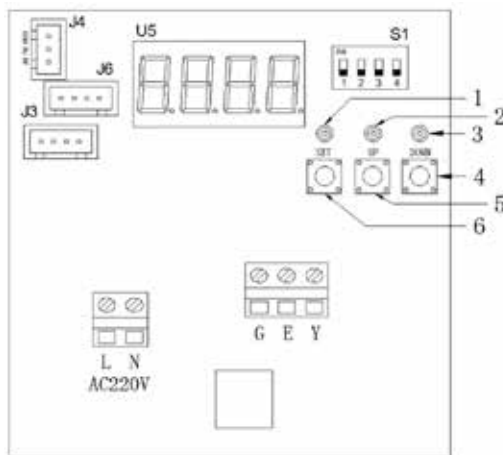
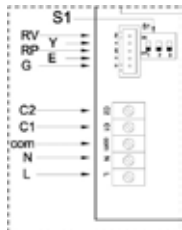

- U5: Display
- 1: "SET" Indicator light
- 2: "UP" Indicator light
- 3: "DOWN" Indicator light
- 4: "DOWN" button
- 5: "UP" button
- 6: "SET" button

- S1: Signal type selector
- J3: Motor socket
- J4: Power socket
- J6: Limit switch socket

Status and setting of 4-digit DIP switch S1

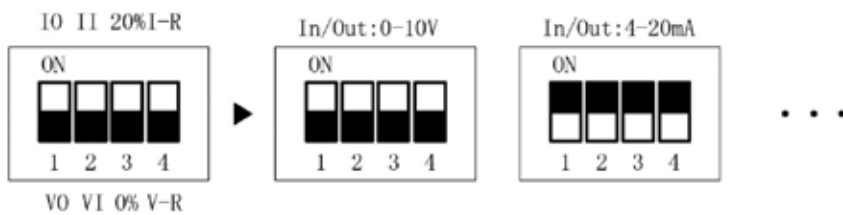

DIP1: Feedback signal type

- ON: current output
- OFF: voltage output

DIP2: input signal type:

- ON: current output
- OFF: voltage input

DIP3: Starting point selector, i.e., percentage of the starting point and full point of input and output signals.

- OFF: 0%; e.g., DC0-10V-DC0-20mA etc.
- ON: 20%; e.g., DC2-10V-DC4-20mA etc.

DIP4: Resistance matching for input signals (The same as the DIP2)

- ON-Perform resistance matching for the current input signal
- OFF- Perform resistance matching for the voltage input signal

S1-DIP	Signal type selector							
	Output signal		Input signal		Starting point selector		Resistance matching for input signals	
	Voltage	Current	Voltage	Current	0%	20%	at voltage	at current
DIP1	OFF	ON						
DIP2			OFF	ON				
DIP3					OFF	ON		
DIP4							OFF	ON



■ Proportional 230 V AC (AVFF...B)

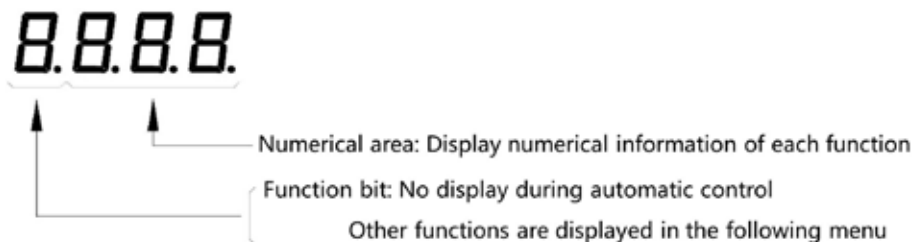

1. Quick debugging (Auto-calibration of valve stroke):

After each power - on of the device, it directly enters the "automatic control" state. In the "automatic control" state, press and hold the ["SET"] key for three seconds, then the auto-calibration program will be started:

- > The actuator rod moves downward first. The "SET indicator light" and "UP indicator light" flash, and the "DOWN indicator light" is always on.
- > Stop slightly at the bottom dead center, memorize it and then move upward. The "SET indicator light" and "DOWN indicator light" flash, and the "UP indicator light" remains on. Move upward to the limit position, stop slightly, memorize it, and then all indicator lights stop flashing. The auto-calibration is completed.

2. Manual/Auto control status

In the normal "automatic control" state, when the ["SET" + "UP"] two keys are pressed simultaneously for three seconds, the "automatic control" and "manual control" states can be switched alternately.

In the "manual control" state, the function bit displays "H", and at this time, the up and down actions of the actuator can be operated through the ["UP"] key or the ["DOWN"] key.

3. Automatic control state

3.1. Feedback signal display

Under the normal "automatic control" state, there is no display of the function bit. At this time, the value displayed in the numerical area of the display screen is the percentage value of the valve position feedback signal.

3.2. Input Signal Display

In the normal "automatic control" state, by switching the ["DOWN"] key, the percentage value of the valve position feedback signal and the percentage value of the input signal can be alternately displayed in the numerical area of the display screen.

When the percentage value of the input signal is displayed in the numerical area, the function position shows " ". After the percentage value of the input signal is displayed for 10 seconds without any operation, it will automatically return to the normal "automatic control" state.

4. Overload alarm function

For the actuator, stalling (when the resistance value of the potentiometer does not change within 30 seconds) at non - extreme positions (near the two dead - point positions, that is, within 5% of approaching zero and full scale) is regarded as a fault. At this time, the current feedback value and E01 are displayed alternately, and the output of the thyristor is cut off. Then, try to output again after 30 seconds, and repeat this process.



■ Engineers set parameters

In the “Automatic Control” state, press and hold the three keys [“SET” + “UP” + “DOWN”] simultaneously for three seconds to enter the engineer parameter setting state. Press the [“SET”] key in sequence, and the function bit and the value area will flash alternately. When the function bit is flashing and the value area is not flashing, you can change the function bit through the [“UP”] and [“DOWN”] keys. When the value area is flashing and the function area is not flashing, you can change the value in the value area through the [“UP”] and [“DOWN”] keys. In the parameter setting state, if there is no operation for more than 10 seconds, it will return to the “Automatic Control” state.

Conventional “Function Bit” Display Table			
Function description	Function bit	Display	Explanation
Position feedback	No display		Numeric range: 0% - 100% In automatic mode, only the position feedback value is displayed. In the automatic state, if you need to view the input signal values, you can use the DOWN key to switch between the position feedback values and the input signal values.
Input signal			Note: After 10 seconds of no operation while the input signal value is displayed, the positioner automatically reverts to the state of displaying the position feedback value.
Manual function			Numeric range: 0% - 100% Only display the position feedback value. It is not allowed to switch to the input signal display state. In this state, the actuator can be operated to run by pressing the “UP” key or the “DOWN” key. Phenomenon: Flashing the current feedback value;
Stroke calibration alarm			E00 = Warning that the stroke calibration has not been completed correctly. Phenomenon: The UP and DOWN indicator lights flash alternately with an interval of 1 second.
Locked Rotor Alarm			E01 = Locked Rotor Alarm (The overload switch has been triggered) 1. Upward rotation blocking alarm Phenomenon-The alarm code E01 flashes, and the SET and UP indicator lights flash together with a cycle of 1 second. 2. Downward blocking alarm Phenomenon-The alarm code E 01 flashes, and the SET and DOWN indicator lights flash together with a cycle of 1 second.
Lost signal alarm			E02= Lost signal alarm In the automatic state, if the input signal line is disconnected, the positioner determines it as a lost signal alarm.
Potentiometer Upper Limit Alarm			E03= Potentiometer upper limit alarm In the automatic state, when the output shaft of the mechanism moves upward to the potentiometer protection position, the positioner determines it as an upper limit alarm.
Potentiometer Lower Limit Alarm			E04= Potentiometer lower limit alarm In the automatic state, when the output shaft of the mechanism descends to the potentiometer protection position, the positioner judges it as a lower limit alarm.
Operating failure			E05 = Actuator running failure, such as abnormal transmission system, or abnormal potentiometer operation, etc. 1. Downward failure Phenomenon: Display E05, and the DOWN indicator light flashes 3 times and pauses for 1s. 2. Upward failure Phenomenon: Display E05, and the UP indicator light flashes 3 times and pauses for 1s.



Level 1 parameter table			
Function description	Function bit	Display	Factory values
Starting point selector	1	1 00 1 01	Selection of the starting point of the input signal. Value range: 00 = 0%, 01 = 20% Note: The DIP switch settings take precedence. This parameter does not need to be set and can use the default value.
Direct or inverse acting selector	2	2 00 2 01	Value range: 00, 01 00= Direct acting (Signal increases, the output shaft of the actuator moves upward) 01= Inverse acting (Signal increases, the output shaft of the actuator moves downward) Note: When not specified, the factory default is "00".
The working mode of the lost signal	3	3 00 3 01 3 02	Value range: 00, 01, 02 00= Downward movement 01= Upward movement 02= Hold the position, Note: The default setting at the factory is "00".
Lower limit value of the stroke Kv-min	4	Value range: 0-55	Stroke limit setting when the input signal is at 0% 00= Disable The factory default is "00".
Upper limit value of the stroke Kv-max	5	Value range: 55-100	Stroke limit setting when the input signal is at 100% 100= Disable; The factory default is "100".
Flow characteristic	6	Value range: 00, 01, 02	The curve relationship between the percentage of the input signal and the percentage of the stroke: 00= Linear, 01= Equal percentage, 02= Reverse equal percentage The factory default is "00".
Rangeability	7	Value range: 25, 30, 33, 50, 60, 80, 100	Only available when the equal percentage characteristic is used. Note: The factory default is "30".
Level 2 parameters unlocking bit	8		Users cannot change it at will. Note: The default factory setting is "08". Set it to "16", and after confirmation, enter the level 2 parameters setting.

Level 2 parameter table			
Function description	Function bit	Display	Factory values
Signal dead zone setting	9	9 05 9 100	Value range: 0.4-10.0 !! Please change with caution. Note: The default factory setting is "0.6", and the dead zone parameter is 0.6%. If it is set to "2.0", after confirmation, the dead zone parameter will be 2.0%.



■ Dimensions (mm)

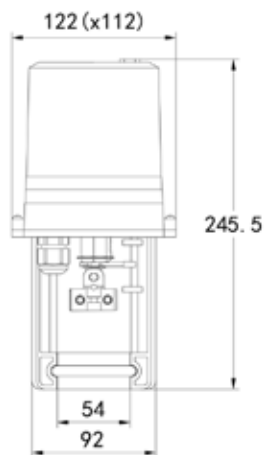

AVFF15...

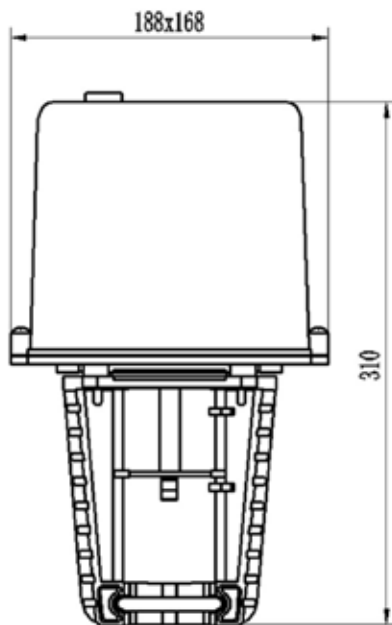

AVFF30...



■ Description

Cast iron valves, VFF 250–300 series, for hot or chilled water flow control in heating, air conditioning and refrigeration systems for civil and industrial applications. DN 250–300. Suitable for AVFF65 and AVFF100 actuators.

■ Technical specifications

Fluid	Hot and cold water (with max. 50% glycol)
Fluid temperature	-25...130°C
Nominal pressure	1600 kPa max (16 bar)
Regulation characteristics	Direct equipercantage path Linear angle path
Regulation capacity	100:1
Leakage	< 0,5 % of KVs
Pipe connection	Flange according EN1092-2
Stroke	See table
Installation position	Horizontal or vertical
Maintenance	Free
Body	QT450 cast iron
Shutter and valve stem	Aisi 304 steel
Seals	PTFE+EPDM
Dimensions and weight	See schedule



2 way	Model	3 way	DN	KVs	Max pres. diff. (bar)*			Stroke D	Actuators
					2 way	3 way (M)	3 way (D)		
VFF2250		VFF3250	250	630	8	1,2	0,7	2 vie 40 3 vie 50	AVFF65...
VFF2300		VFF3300	300	990	8	1,2	0,7	70	AVFF100...

■ Warnings

Before installing the valves, ensure that the pipes are clean, free of welding slag, perfectly aligned with the valve body and not subject to vibrations. The valve can be installed in any position except upside down. When installing, observe the flow directions indicated by the arrows on the valve body.

With the stem extended (up), the direct path is closed; with the stem retracted (down), the direct path is open.

VFF 250-300



Installation

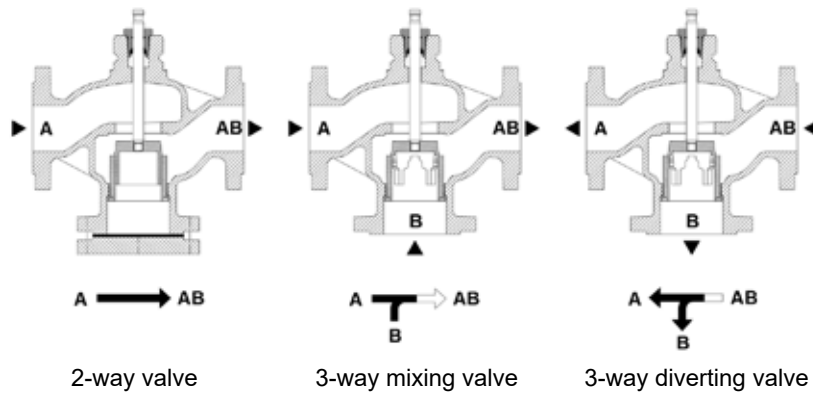

Flow control characteristic

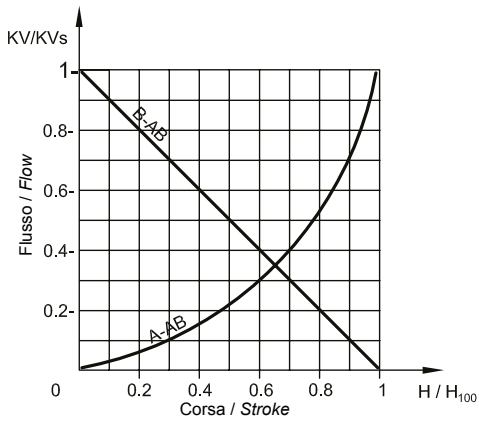

Port A-AB equal-percentage
 Bypass B-AB linear
 Used as mixing valve
 flow from A and B, outlet to AB
 Used as diverting valve
 flow from AB, outlet to A and B
Port AB constant flow
Port A variable flow
Port B (bypass) variable flow

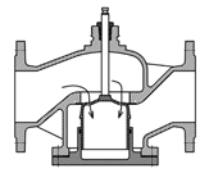

2-way
(DN125-DN300)
with pressure
compensated

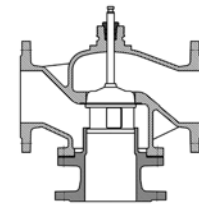

3-way
(DN65-DN300)

Dimensions and weights

Model	Connection		Dimension (mm)					Weight kg
	DN	L	D	K	H5	H2	h	
VFF2250	250	622	405	355	248	392	100	162
VFF3250								225
VFF2300	300	698	460	410	280	389	100	215
VFF3300								234

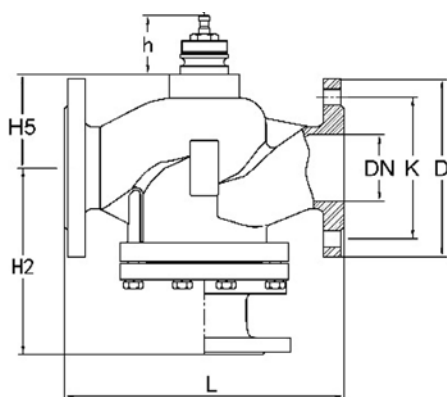

Actuator for flanged globe valve DN250, DN300

AVFF65, AVFF100



Description

Linear electric actuator AVFF65/100 series for HVAC applications. Supports 0–10 V / 4–20 mA control signals, high accuracy (up to 0.4%), stroke up to 100 mm and thrust up to 10 kN. Compact and reliable, featuring auto-calibration, manual operation, and complete overload protection.

Technical specifications

Power supply	230 V AC \pm 10% 50/60 Hz
Power consumption	\leq 35 VA
Electrical connection	Screw terminal, 1,5 mm ²
Torque	6500 N, 10000 N
Running time	2,1 sec./mm (50Hz)
Materials	ABS cover, self-extinguishing Aluminium bracket
Protection degree	IP65
Life time	at least 80.000 cycles
Working range °C	-5...+55°C
Storage temperature and humidity	-25...+55°C, 1...95% RH, non-condensing
Maintenance	free



Models	Force kN	Action	Input signal	Stroke mm	Speed	DN mm
AVFF65B	6,5	on-off, floating	3-points	60	2,1 mm/s	250
AVFF65BM		proportional	0(2)...10 V DC - 0(4)...20 mA			
AVFF100B	10	on-off, floating	3-points	100		300
AVFF100BM		proportional	0(2)...10 V DC - 0(4)...20 mA			

Electrical wiring

On-off, floating

Proportional

On-off, floating

Proportional with
two auxiliary switches

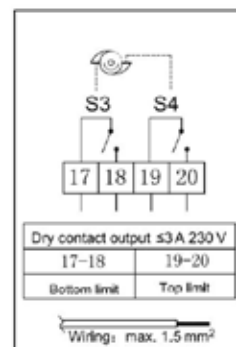
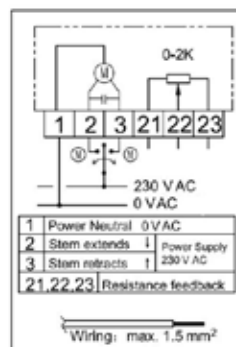
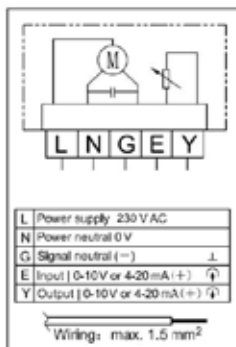
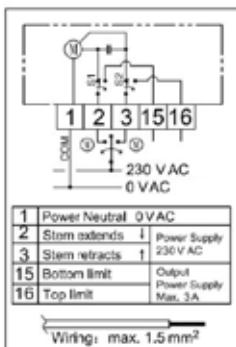



Mounting instructions

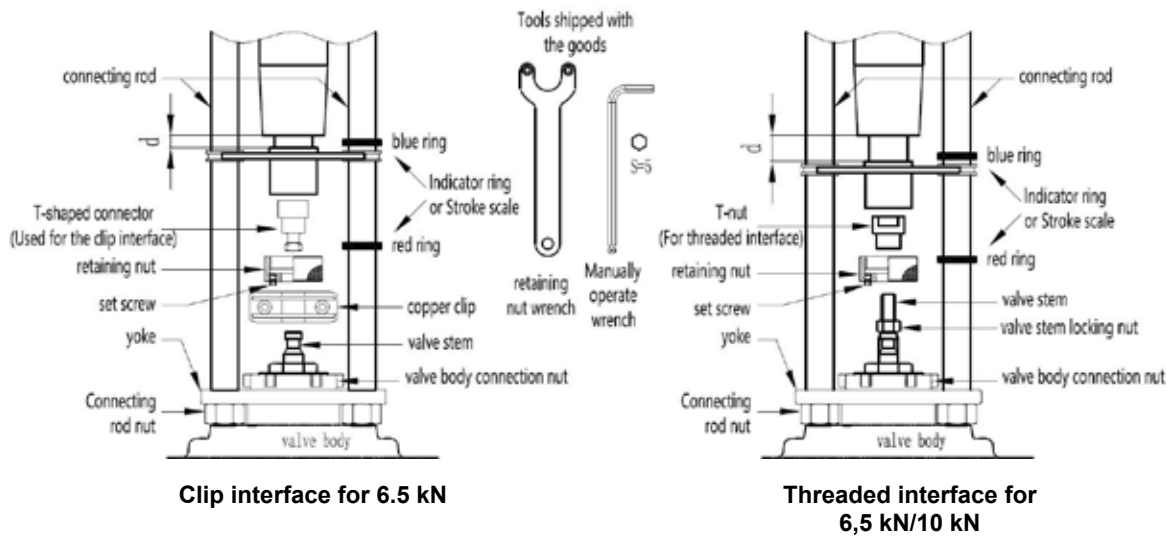

Clip interface for 6.5 kN

Threaded interface for 6,5 kN/10 kN

As shown in the figure above, install the electric actuator of the corresponding model onto the required regulating valve body: the connection dimensions between the valve and the actuator

Assembly steps for Clip interface:

- 1) Remove a pair of "copper clips" and "valve body connection nuts" from the actuator and set them aside for future use.
- 2) Before installation, the valve stem of the valve should be at the top position; Place the actuator on the valve and use the output stem of the actuator to push the valve stem to an appropriate position, ensuring that the end faces of the two stems coincide.
- 3) Insert the "valve body connection nut" between the top of the valve stem and the actuator rod, slip it onto the neck of the valve, screw it to the root to fix the actuator, but do not tighten it.
- 4) When the end faces of the actuator shaft and the valve stem do not coincide, use the "manual operation wrench" to make the output shaft of the actuator run downward until they coincide, and then stop.
- 5) Use the "copper clip", buckle them together, clamp the valve stem and the actuator shaft and connect them together, and fix them firmly with the matching screws and nuts; (Pay attention to the installation direction of the clip. If it is installed backwards, it cannot be used!)
- 6) Power on the actuator or operate it manually, move the mechanism upward to the top limit position, allow the mechanism to automatically align under tension and maintain a coaxial state, and then tighten the "valve body connection nut".
- 7) Itinerary Instructions:
 - Indicator ring: Slide the indicator ring so that it is close to the pointer.
 - Stroke scale: Paste the stroke scale indicator on the outer surface of the clean and legible "connecting rod".

Assembly steps for threaded interface:

- 1) Remove the "valve body connection nut", "retaining nut" on the actuator and the "T-nut" inside.
- 2) Push the valve stem to the bottommost position, and screw the "valve stem locking nut" to the lowermost end of the connecting thread of the "valve stem".
- 3) Put the unscrewed "retaining nut" onto the valve stem and place it loosely on the "valve stem jam nut".
- 4) Crew the "T-nut" into the valve stem in the direction shown in the above figure. When the upper surface of the "valve stem" is 0-5mm lower than the upper surface of the nut, tighten the "valve stem locknut" in the reverse direction to fix the "T-nut".
- 5) Manually operate the actuator to make the lower end face of the output shaft of the actuator move away from the upper end face of the valve stem or run to the uppermost position.
- 6) Insert the "valve body connecting nut" between the top of the valve stem and the actuator rod, put the actuator onto the valve body, slide the "valve body connecting nut" to the valve neck, and screw it to the root to fix the actuator, but do not tighten it.
- 7) Power on or manually operate the actuator to run downward. After the output shaft contacts the "retaining nut", tighten the "retaining nut" onto the output shaft, and finally tighten the "set screw" to prevent loosening.
- 8) Power on the actuator or operate it manually, move the mechanism upward to the top limit position, allow the mechanism to automatically align under tension and maintain a coaxial state, and then tighten the "valve body connection nut".
- 9) Itinerary Instructions:
 - Indicator ring: Slide the indicator ring so that it is close to the pointer.
 - Stroke scale: Paste the stroke scale indicator on the outer surface of the clean and legible "connecting rod".
- 10) The mechanical connection is completed. The 3-Point control signal can be used directly. For the analog control signal, it needs to be powered on and go through the Stroke self-calibration before use.

Note: When the actuator descends to the lower dead center of the valve, the exposed length d of the output shaft nut (as shown in the figure) should be \leq the rated stroke of the actuator (60mm or 100mm) to prevent the output shaft of the actuator from disengaging from the mechanism.

AVFF65, AVFF100



■ Mounting instructions

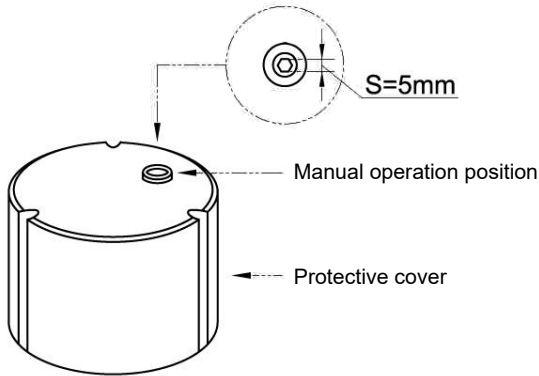

Manual operation function is used to debug the equipment during on - site installation or in case of an emergency when an electrical failure occurs.

The steps are as follows:

1. Cut off the power supply of the actuator at the handwheel shaft.
2. Connect (with a size of 5mm) to the handwheel shaft through the manual operation installation hole on the cap.
3. According to the on - site usage situation, rotate the wrench clockwise or counter - clockwise. The rotation speed should be $\geq 6s/r$ (to prevent the equipment mechanism from being damaged due to excessive rotation speed).
 - When rotating clockwise, the output shaft of the actuator moves upward.
 - When rotating counter - clockwise, the output shaft of the actuator moves downward.
4. After the valve reaches the designated position, stop rotating and take out the wrench.

Note: 1. During manual operation, it is strictly prohibited for the pointer to exceed the range of the upper and lower indicator rings.
 2. When the output shaft is working within the range of the indicator ring, if significant resistance is encountered, determine the cause before further operation.

■ Technology

3 position control signal

Terminals 1 - 2 are powered on: The actuator stem extends.

Terminals 1 - 3 are powered on: The actuator stem retracts.

No voltage on 2 and 3 the actuator stem remain in the respective position.

Note: It is strictly prohibited to power on terminals 1 - 2 and 1 - 3 simultaneously. Otherwise, the equipment will be damaged!

Instructions for the actuator panel with an electronic locator

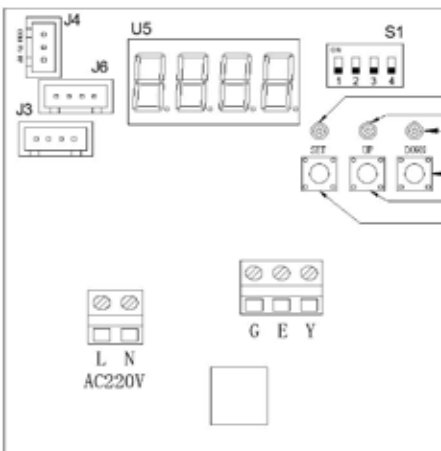

- U5: display
- 1: SET Indicator light
- 2: UP Indicator light
- 3: DOWN Indicator light
- 4: DOWN button
- 5: UP button
- 6: SET button
- S1: Signal type selector
- J3: Motor socket
- J4: Power socket
- J6: Limit switch socket

Status and setting of 4-digit DIP switch S1

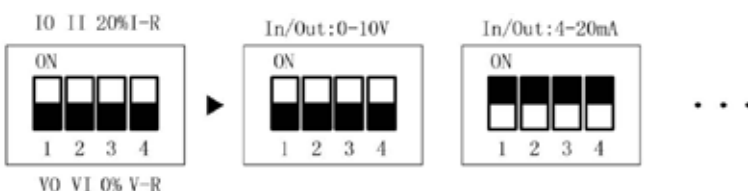

DIP1: Feedback signal type: ON= current output, OFF= voltage output

DIP2: input current input, OFF= voltage input

DIP3: Starting point selector, i.e., percentage of the starting point and full point of input and output signals.

OFF: 0%; e.g., DC0-10V, DC0-20mA etc. ON: 20%; e.g., DC2-10V, DC4-20mA etc.

DIP4: Resistance matching for input signals (The same as the DIP2)

ON-Perform resistance matching for the current input signal OFF- Perform resistance matching for the voltage input signal



S1-DIP	Signal type selector							
	Output signal type		Input signal type		Starting point selector		Resistance matching for input signals	
	voltage output	current output	voltage Input	current input	0%	20%	at voltage	at current
DIP1	OFF	ON						
DIP2			OFF	ON				
DIP3					OFF	ON		
DIP4							OFF	ON

Function Description

Numerical area: Display numerical information of each function.

Function bit: No display during automatic control.

Other functions are displayed in the following menu.

1. Quick debugging (Auto-calibration of valve stroke):

After each power - on of the device, it directly enters the “automatic control” state. In the “automatic control” state, press and hold the [“SET”] key for three seconds, then the auto-calibration program will be started:

- The actuator rod moves downward first. The “SET indicator light” and “UP indicator light” flash, and the “DOWN indicator light” is always on.
- Stop slightly at the bottom dead center, memorize it and then move upward. The “SET indicator light” and “DOWN indicator light” flash, and the “UP indicator light” remains on. Move upward to the limit position, stop slightly, memorize it, and then all indicator lights stop flashing. The auto-calibration is completed.

2. Manual/Auto control status

In the normal “automatic control” state, when the [“SET” + “UP”] two keys are pressed simultaneously for three seconds, the “automatic control” and “manual control” states can be switched alternately. In the “manual control” state, the function bit displays “H”, and at this time, the up and down actions of the actuator can be operated through the [“UP”] key or the [“DOWN”] key.

3. Automatic control state

3.1 Feedback signal display

Under the normal “automatic control” state, there is no display of the function bit. At this time, the value displayed in the numerical area of the display screen is the percentage value of the valve position feedback signal.

3.2 Input Signal Display

In the normal “automatic control” state, by switching the [“DOWN”] key, the percentage value of the valve position feedback signal and the percentage value of the input signal can be alternately displayed in the numerical area of the display screen. When the percentage value of the input signal is displayed in the numerical area, the function position shows “. After the percentage value of the input signal is displayed for 10 seconds without any operation, it will automatically return to the normal “automatic control” state.

4. Overload alarm function:

For the actuator, stalling (when the resistance value of the potentiometer does not change within 30 seconds) at non - extreme positions (near the two dead - point positions, that is, within 5% of approaching zero and full scale) is regarded as a fault. At this time, the current feedback value and E01 are displayed alternately, and the output of the thyristor is cut off. Then, try to output again after 30 seconds, and repeat this process.



■ Engineers set parameters

In the "Automatic Control" state, press and hold the three keys ["SET" + "UP" + "DOWN"] simultaneously for three seconds to enter the engineer parameter setting state. Press the ["SET"] key in sequence, and the function bit and the value area will flash alternately. When the function bit is flashing and the value area is not flashing, you can change the function bit through the ["UP"] and ["DOWN"] keys. When the value area is flashing and the function area is not flashing, you can change the value in the value area through the ["UP"] and ["DOWN"] keys. In the parameter setting state, if there is no operation for more than 10 seconds, it will return to the "Automatic Control" state.

Conventional "Function Bit" Display Table

Function description	Function bit	Display	Explanation
Position feedback	No display		Numeric range: 0% - 100% In automatic mode, only the position feedback value is displayed. In the automatic state, if you need to view the input signal values, you can use the DOWN key to switch between the position feedback values and the input signal values.
Input signal			Note: After 10 seconds of no operation while the input signal value is displayed, the positioner automatically reverts to the state of displaying the position feedback value.
Manual function			Numeric range: 0% - 100% Only display the position feedback value. It is not allowed to switch to the input signal display state. In this state, the actuator can be operated to run by pressing the „UP“ key or the „DOWN“ key. Phenomenon: Flashing the current feedback value
Stroke calibration alarm			E00 = Warning that the stroke calibration has not been completed correctly. Phenomenon: The UP and DOWN indicator lights flash alternately with an interval of 1 second.
Locked Rotor Alarm			E01 = Locked Rotor Alarm (The overload switch has been triggered) 1. Upward rotation blocking alarm Phenomenon-The alarm code E01 flashes, and the SET and UP indicator lights flash together with a cycle of 1 second. 2. Downward blocking alarm Phenomenon-The alarm code E01 flashes, and the SET and DOWN indicator lights flash together with a cycle of 1 second.
Lost signal alarm			E02= Lost signal alarm In the automatic state, if the input signal line is disconnected, the positioner determines it as a lost signal alarm.
Potentiometer Upper Limit Alarm			E03= Potentiometer upper limit alarm In the automatic state, when the output shaft of the mechanism moves upward to the potentiometer protection position, the positioner determines it as an upper limit alarm.
Potentiometer Lower Limit Alarm			E04= Potentiometer lower limit alarm In the automatic state, when the output shaft of the mechanism descends to the potentiometer protection position, the positioner judges it as a lower limit alarm.
Operating failure			E05 = Actuator running failure, such as abnormal transmission system, or abnormal potentiometer operation, etc. 1. Downward failure Phenomenon: Display E05, and the DOWN indicator light flashes 3 times and pauses for 1s. 2. Upward failure Phenomenon: Display E05, and the UP indicator light flashes 3 times and pauses for 1s.



Level 1 parameter table			
Function description	Function bit	Display	Factory values
Starting point selector	1	1 00 1 01	Selection of the starting point of the input signal. Value range: 00 = 0%, 01 = 20% Note: The DIP switch settings take precedence. This parameter does not need to be set and can use the default value.
Direct or inverse acting selector	2	2 00 2 01	Value range: 00, 01 00= Direct acting (Signal increases, the output shaft of the actuator moves upward) 01= Inverse acting (Signal increases, the output shaft of the actuator moves downward) Note: When not specified, the factory default is "00".
The working mode of the lost signal	3	3 00 3 01 3 02	Value range: 00, 01, 02 00= Downward movement 01= Upward movement 02= Hold the position, Note: The default setting at the factory is "00".
Lower limit value of the stroke Kv-min	4	Value range: 0-55	Stroke limit setting when the input signal is at 0% 00= Disable The factory default is "00".
Upper limit value of the stroke Kv-max	5	Value range: 55-100	Stroke limit setting when the input signal is at 100% 100= Disable; The factory default is "100".
Flow characteristic	6	Value range: 00, 01, 02	The curve relationship between the percentage of the input signal and the percentage of the stroke: 00= Linear, 01= Equal percentage, 02= Reverse equal percentage The factory default is "00".
Rangeability	7	Value range: 25, 30, 33, 50, 60, 80, 100	Only available when the equal percentage characteristic is used. Note: The factory default is "30".
Level 2 parameters unlocking bit	8		Users cannot change it at will. Note: The default factory setting is "08". Set it to "16", and after confirmation, enter the level 2 parameters setting.

Level 2 parameter table			
Function description	Function bit	Display	Factory values
Signal dead zone setting	9	9 05 9 100	Value range: 0.4-10.0 !! Please change with caution. Note: The default factory setting is "0.6", and the dead zone parameter is 0.6%. If it is set to "2.0", after confirmation, the dead zone parameter will be 2.0%.



■ Installation and Precautions

10.1 Installation requirements

- Easy to access.
- Leave space to remove the protective cover.
- The actuator shall not be installed upside down.
- Pay attention to the operating ambient temperature.
- For actuators installed outdoors, a protective cover must be installed, and attention should be paid to ventilation and heat dissipation. Please note that the interior of this actuator should not be wetted or frosted.
- Before connecting the power supply, please make sure that the power supply voltage is consistent with the voltage marked on the nameplate of this actuator.
- This actuator is not allowed to operate naked to prevent mechanical entanglement or electric shock hazards.

10.2 Transportation and Storage

- Appropriate packaging must be carried out according to the transportation conditions for delivery to the installation site.
- It is prohibited to place any device on the actuator.
- Store in a dry and well - ventilated place and prevent it from getting damp.
- Cover it to prevent dust.
- Apply anti - corrosion paint to the bright metal surface.

10.3 Maintenance and Upkeep

Note: Cut off the power supply of the equipment before any maintenance work.

Under normal use conditions, non-professionals should not easily open the protective cover of the actuator. The actuator itself can operate normally for several years.

During maintenance: If it is necessary to force open or close the electric valve, the actuator can be operated through the handwheel mechanism. If there is no handwheel configured, the actuator can be operated by means of powered operation.

After startup: Check if there is any paint damage on the entire machine. If necessary, repaint it to prevent corrosion.

For rare startups: Check the performance of the actuator every six months after startup.

One year later: Check whether the mechanical connection with the valve body is reliable. If necessary, tighten it again. Check whether the lubrication of the gears and transmission parts is dry. If needed, add an appropriate amount of high-quality solid lubricating grease.

A few years later: Depending on the operating condition of the equipment after a few years, if major repairs or adjustments are required, please consult us for a comprehensive maintenance plan.

■ Dimensions (mm)

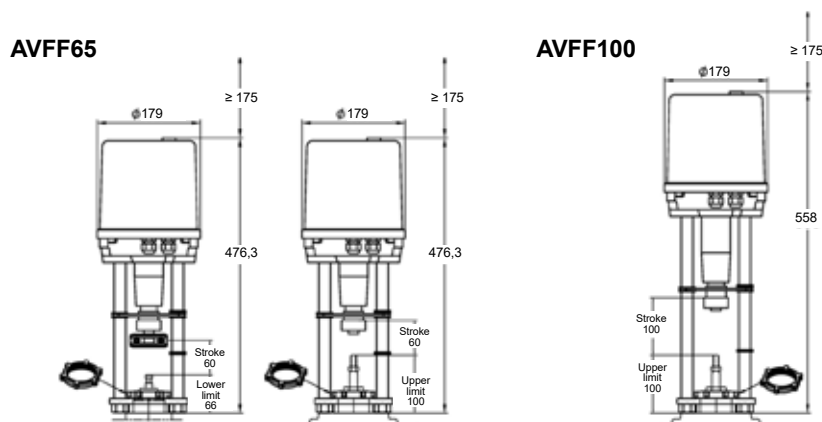

Stem heater for flanged globe valves VFF

Description



The VH heater allows the valve to operate even in harsher environmental conditions, extending the temperature range below the nominal values specified in the catalog.

Technical specifications

Power supply	24 V AC / DC
Power consumption	20-30 W
Heating temperature IP	80–120 °C
Protection rating	IP43
Material	Aluminum and stainless steel
Standards	CE and RoHS compliance

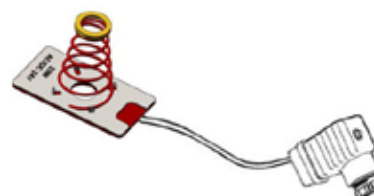

Electrical connections

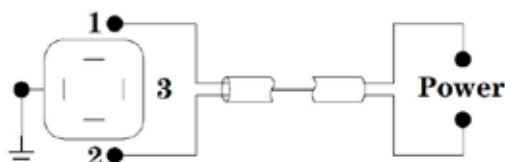

Installation instructions

- 1) Lift the valve stem and clean the surface of the stem and the stuffing box.
- 2) Assemble the heating unit.
- 3) Secure the heating component with the appropriate clamps.
- 4) Install the actuator and complete the mechanical assembly.

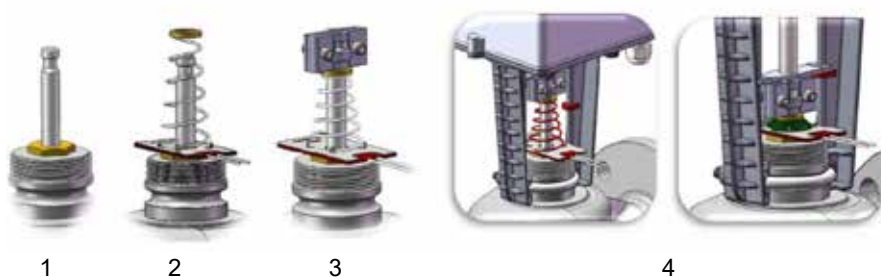

Safety notes:

Ensure that the power supply is disconnected before performing any installation work.
Do not exceed the maximum specified temperature to avoid damage.
Use only original components for repairs.

Butterfly valves

VM



Description

The VM series of butterfly valves (Wafer) are used in heating, refrigeration and air-conditioning systems for the flow control of heated or chilled water for domestic and industrial applications. The valves can be coupled with our 24 or 230 VAC modulating or 2-3 points actuators with or without auxiliary switches.

Technical specifications

Fluid	Hot and cold water (with glycole max. 50%)
Valve size	DN40 - DN150
Control flow characteristics	Equal-percentage
Body	Aluminium ADC12
Seat	EPDM
Shaft	X30Cr13 (AISI 420)
Disk	Nodular iron GJS500
Max working pressure	PN10
Maintenance	free
Water temperature	-15...+90°C
Storage temperature	+20...+80°C, dry and dust-free, far from direct sunlight
Standards	CE-conformity, RoHS



Models	KVs	Max diff. pressure (bar)	Actuator type
VM 40	50	12	S16..
VM 50	85	10	S16..
VM 65	215	8	S16..
VM 80	420	8	S16..
VM 100	800	6	S16..
VM 125	1010	6	S24..
VM 150	2100	4	S32..

Flow control characteristic

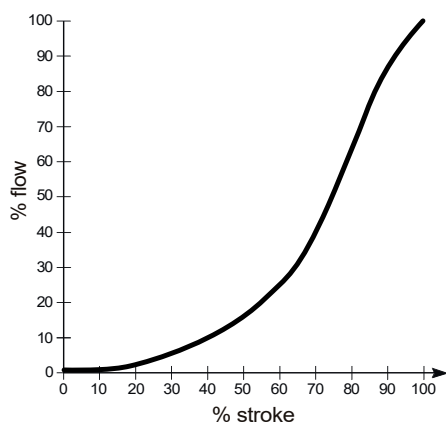

The flow characteristic of VM valves is equipercentage (see diagram).



Dimensions (mm)

DN	A	B	C	D	E
40	151	217	83	284	33
50	166	239	104	306	43
65	172	258	121	325	46
80	170	260	132	327	46
100	187	295	154	362	52
125	205	324	189	391	56
150	217	349	218	416	56

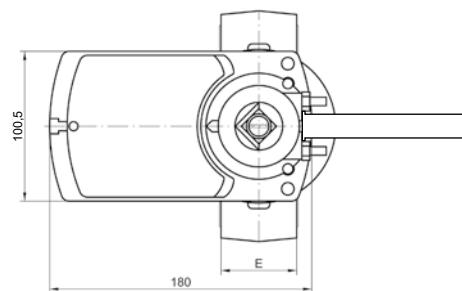
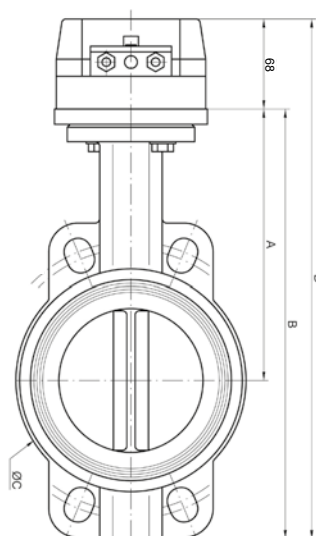

Electrical wirings for models at 2 / 3 points

Wiring diagram

2- point

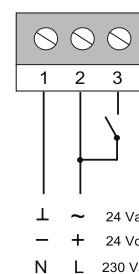

3- point

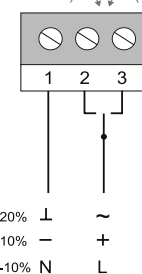

\perp ~ 24 Vac +/-20%
 \perp + 24 Vdc +/-10%
 N L 230 Vac +/-10% N L

Auxiliary switches

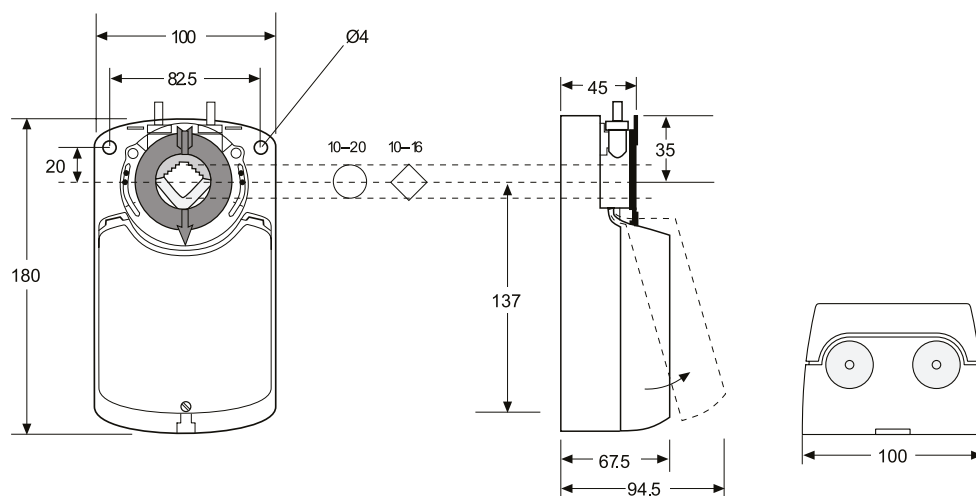
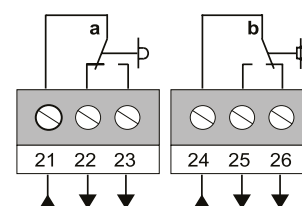

Auxiliary switch adjustment

Factory setting:
 switch a at 10°
 switch b at 80°
 The switching position can be changed manually.

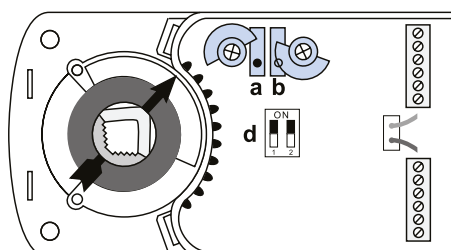

Angle of rotation limiting

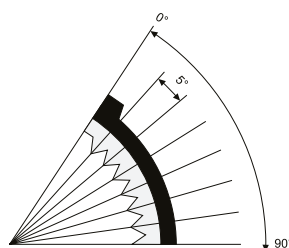

Adapter release

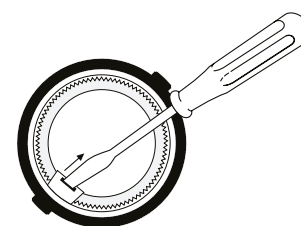
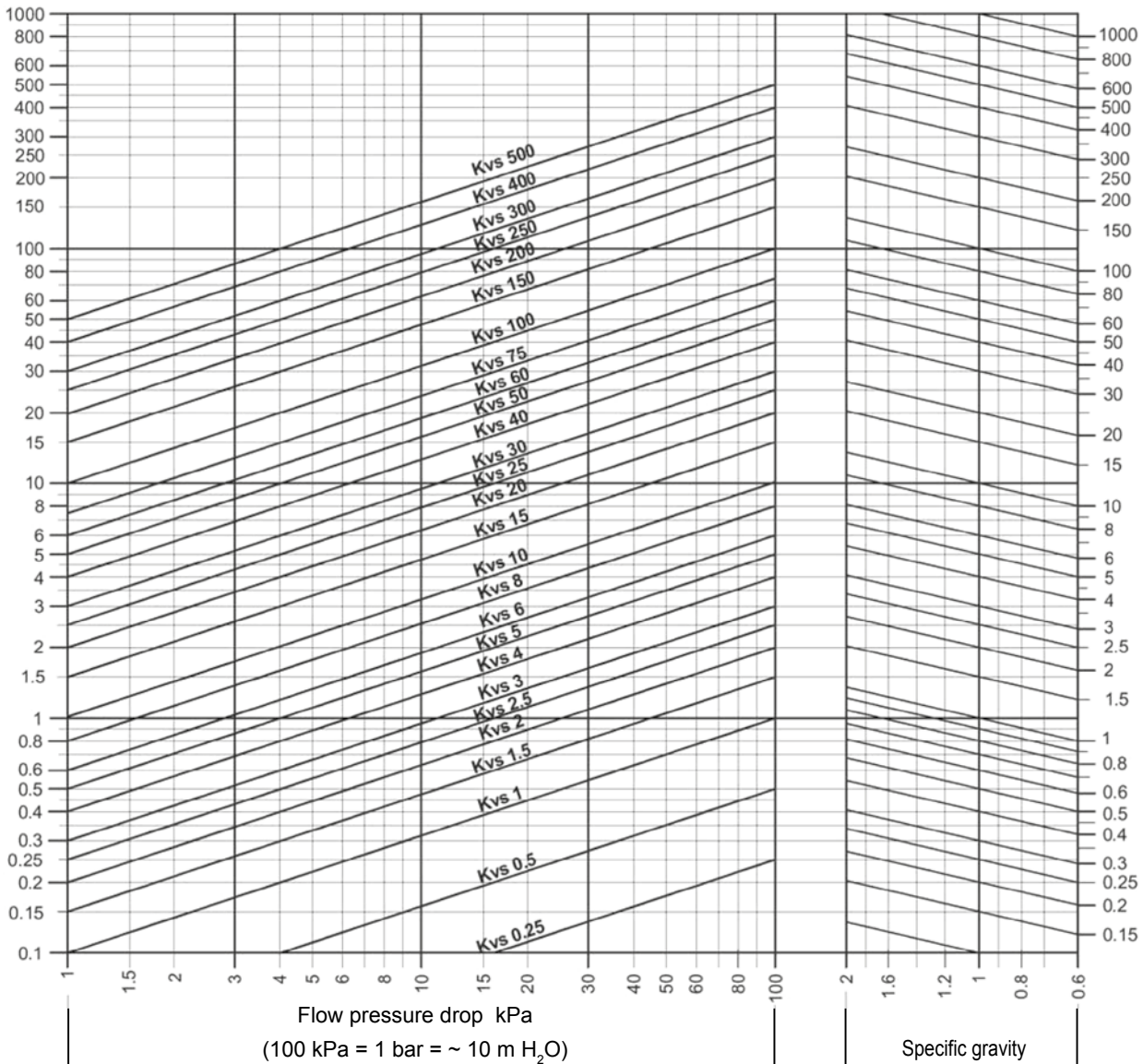

Diagram of pressure losses for liquids



Example for fluids with specific gravity 1 kg/dm^3 (water)

Flow: $7.5 \text{ m}^3/\text{h}$ water

Pressure drop: 55 kPa

Locate the crossing point between the line with starting point at flow value $7.5 \text{ m}^3/\text{h}$ and the line at pressure drop value 55 kPa. This point corresponds to flow coefficient KVs 10, therefore control valve must have KVs = 10.

Example for fluids with specific gravity different than 1 kg/dm^3

Flow: $30 \text{ m}^3/\text{h}$ fluid with specific gravity 0.9 kg/dm^3

Pressure drop: 20 kPa

Locate the crossing point (right side of diagram) between the line with starting point at specific gravity value 0.9 kg/dm^3 and the sloping line at flow value $30 \text{ m}^3/\text{h}$.

Locate the crossing point between the line with starting point at above crossing point and the line at pressure drop value 20 kPa. This point corresponds to flow coefficient KVs 63, therefore control valve must have size KVs = 63 (DN65).



grayline

humidistats



Description

The room humidistat HR1 is controlling the relative humidity in domestic, commercial or industrial applications and can drive fans, humidifiers or dehumidifiers bringing the moisture level of the value set on his knob. The modern and elegant housing to complement any type of interior design.

Technical specifications

Sensible element	Stabilised synthetic textile tape
Wiring terminals	Screw terminals for wires up to 1,5 mm ²
Electrical rating	max 5 (3) A, 250 VAC min 100 mA, 24 VAC
Working range	30...90% RH
Differential	8% RH
Accuracy	±5% RH*
Humidity calibration	55% RH at 23°C
Long term stability	approx. -1,5% RH/year
Time constant in moving air (0.2 m/s)	approx. 5 minutes
Working temperature	0...50°C
Storage temperature	-25...70°C no condense
Admissible ambient humidity	10...95% RH no condense
Materials	Housing of flame-retardant thermoplastic
Protection type	IP30
Protection class	II
Standards	CE-conformity, RoHS



(*) The setting accuracy of the humidistat at the calibration point is ± 5% rh at 55% rh, 23°C after initial calibration at the factory. Setting accuracy see diagram "Setting accuracy". In general, humidity sensors (humidistats) are subject to increased ageing if they are used and/or stored in very contaminated air or aggressive gases. Under these conditions, the humidistat may drift prematurely and alter the linearity.

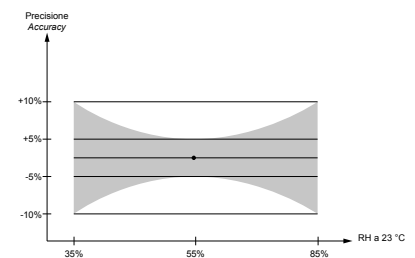

Operation

When the relative humidity rises and reaches the upper switching point, contacts 1-2 open and 1-3 close. The setpoint XS corresponds to the upper switching point. The contacts revert to their original position when the humidity has fallen below the upper switching point by the amount of the fixed switching difference (Δ) of 6% RH.

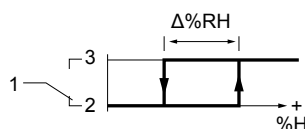



Electrical wirings

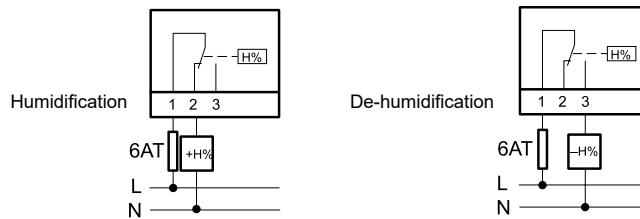

Installation

DANGER

Electrical connection

Danger of electrocution! The removal of this cover exposes parts which carry mains voltage.

- The unit should be opened only by a qualified electrician or by the manufacturer's service personnel.
- Before starting any work on the electrical connections, separate the unit from the mains power supply.
- Do not apply power to the unit until it has been completely re-assembled and the housing has been closed.
- To prevent access by unqualified persons and, in particular, children, do not leave the opened unit unattended.

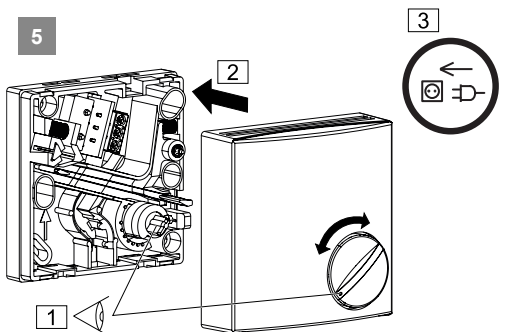
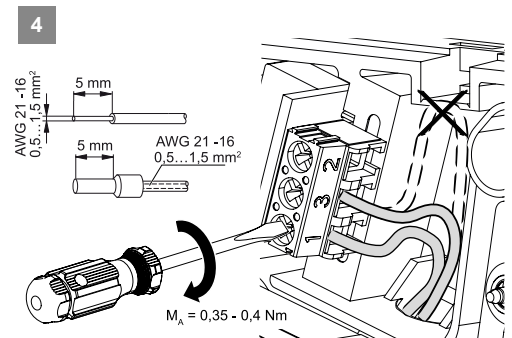
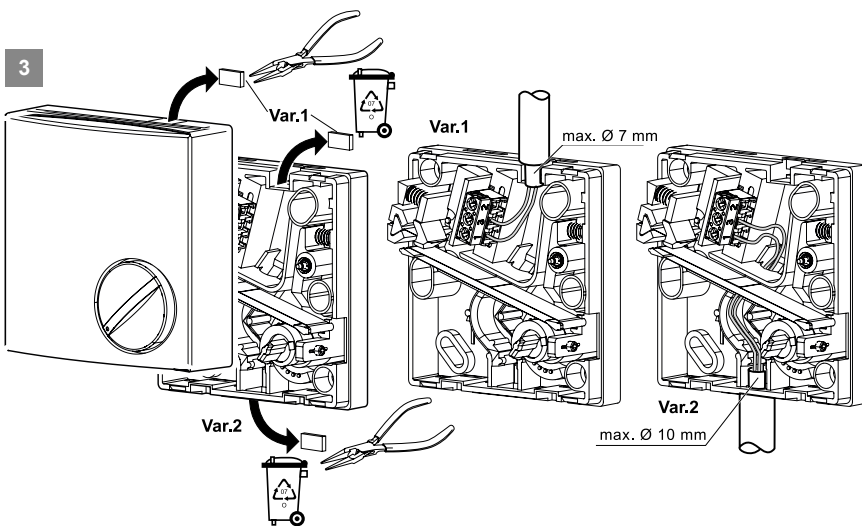
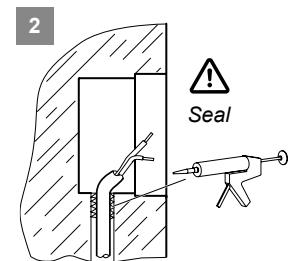
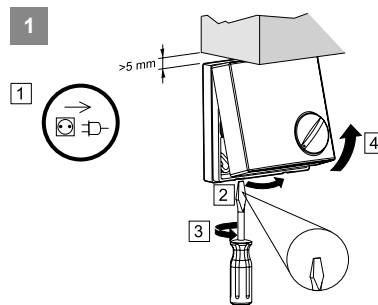
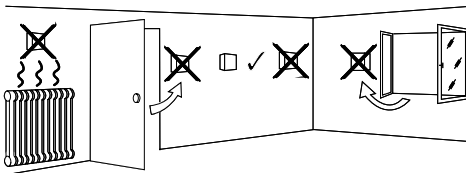
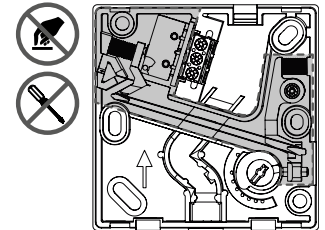

Dimensions (mm)

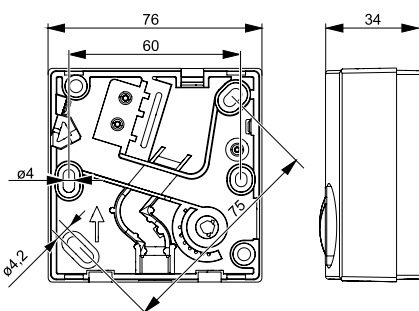



■ Description

The duct humidistat HD1 is controlling the relative humidity in pipes and air ducts, in commercial or industrial applications and can drive fans, humidifiers or dehumidifiers bringing the moisture level of the value set on his knob. It comes supplied with plastic bracket for wall mounting and gasket for mounting on air ducts.

■ Technical specifications

Sensible element	Stabilised synthetic textile tape, temperature-compensated
Wiring terminals	Screw terminals for wires up to 1,5 mm ²
Electrical rating	Max 5 (3) A, 250 VAC Min 100 mA, 24 V
Setting range	15...95% RH
Working range	30...90% RH no condense
Differential	4% RH (after umidity calibration)
Accuracy	±5% RH*
Humidity calibration	55% RH at 23°C
Max. air speed	10 m/sec.
Long term stability	approx. -1,5% RH/year
Time constand in moving air (0.2 m/s)	approx. 3 minutes
Working temperature	0...70°C
Storage temperature	-20...70°C no condense
Admissible ambient humidity	10...95% RH no condense
Materials	Housing of flame-retardant thermoplastic
Protection type	IP30
Protection class	II
Standards	CE-conformity, RoHS



(*) The setting accuracy of the humidistat at the calibration point is ± 5% rh at 55% rh, 23°C after initial calibration at the factory. Setting accuracy see diagram "Setting accuracy". In general, humidity sensors (humidistats) are subject to increased ageing if they are used and/or stored in very contaminated air or aggressive gases. Under these conditions, the humidistat may drift prematurely and alter the linearity.

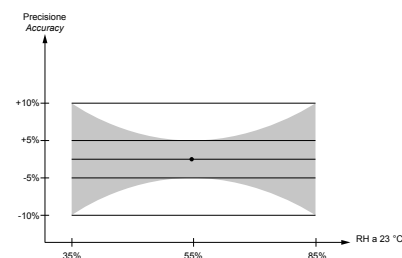

■ Operation

When the relative humidity rises and reaches the upper switching point, contacts 1-2 open and 1-3 close. The setpoint corresponds to the upper switching point. The contacts revert to their original position when the humidity has fallen below the upper switching point by the amount of the fixed switching difference (Δ) of 4% RH.

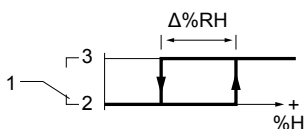



Electrical wirings

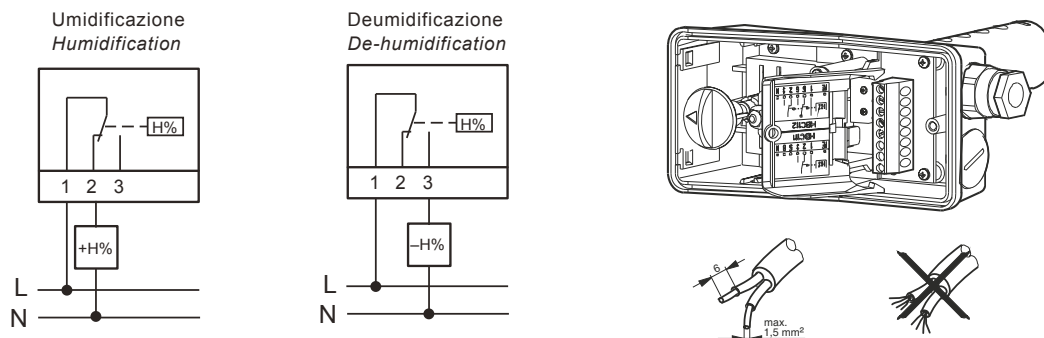

Installation

⚠ DANGER

Electrical connection

Danger of electrocution! The removal of this cover exposes parts which carry mains voltage.

- The unit should be opened only by a qualified electrician or by the manufacturer's service personnel.
- Before starting any work on the electrical connections, separate the unit from the mains power supply.
- Do not apply power to the unit until it has been completely re-assembled and the housing has been closed.
- To prevent access by unqualified persons and, in particular, children, do not leave the opened unit unattended.

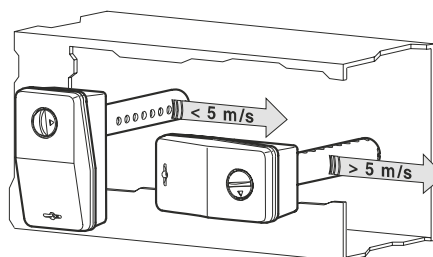
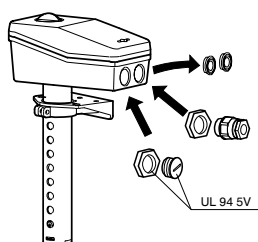
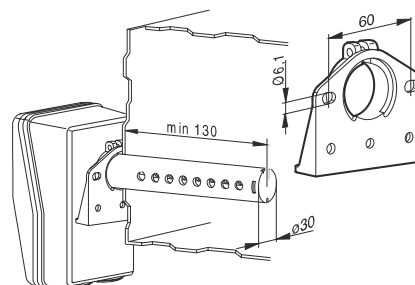
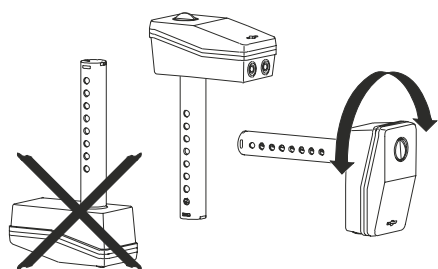

Dimensions (mm)

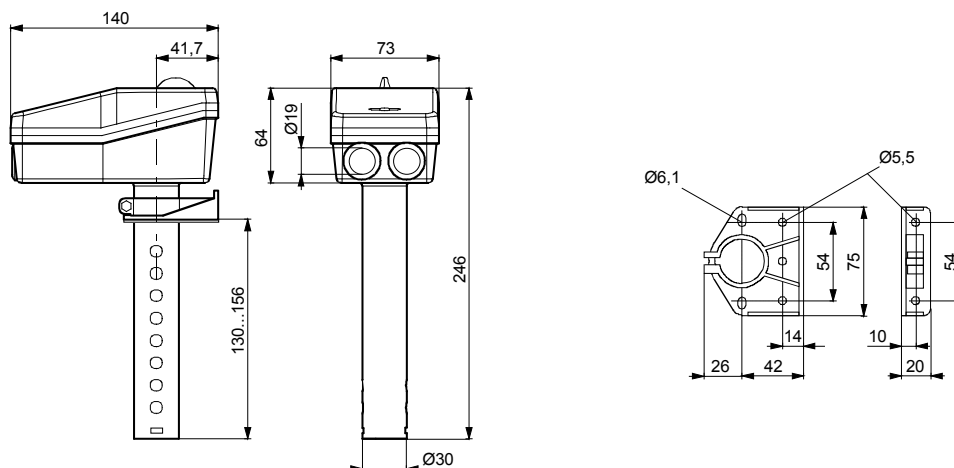

transmitters



Description

The room humidity/temperature transmitter serie KTI measures the temperature and humidity by capacitive sensors and converts the value into a linear output signal 0...10 VDC or 4...20 mA.

Technical specifications

Measurement range RH	0...100 % RH
Accuracy RH	2 % RH
Measurement range °C	0...50°C, 0...100°C, -30...+70°C, -40...+60°C
Accuracy °C	0,5°C
Power supply	24 VAC (±5%) 50-60 Hz / 15...35 VDC
Power consumption	< 2,5 W
Working resistance at 0...10 VDC	min. 1 kOhm
Working resistance at 4...20 mA	max 500 Ohm
Electrical connection	Screw terminals max. 1,5 mm ²
Housing	ABS
Dimensions	See drawing
Protection type	IP41
Working range RH	0...98% RH in contaminant-free, non-condensing air
Working temperature °C	-30...+80°C
Standards	CE conformity, RoHS



Order matrix

Model	Accuracy	Output 1 Humidity		Output 2 Temperature		Option	
KTI	2 % RH	0	no output	0	no output	M	Modbus
		1	0...10 V	1	0...10 V	D	Display
		2	2...10 V	2	2...10 V	R	Relay*
		3	0...5 V	3	0...5 V		
		4	1...5 V	4	1...5 V		
		5	4...20 mA	5	4...20 mA		

* The relay option is available only with display.

DIP Switch

DIP	Temp. Ranges
	0...50°C
	0...100°C
	-30...+70°C
	-40...+60°C

DIP	Response
	1 sec.
	5 sec.
	10 sec.
	30 sec.



Transmitter hardware

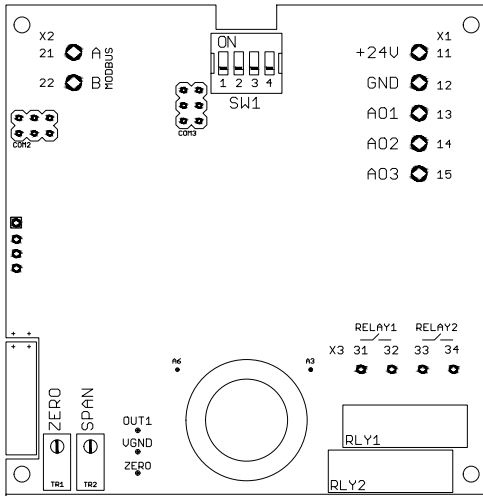

SW1 DIP Switch for configuration range and response time

X1 TERMINAL

11	24V	15...35 VDC or 24 VAC (\pm %5, 50-60 Hz)
12	GND	ground for power and reference for outputs
13	AO1	analog output 1
14	AO2	analog output 2
15	AO3	analog output 3

X2 TERMINAL

21	A / RS485	modbus communication positive pair
22	B / RS485	modbus communication negative pair

TR1 not used

TR2 not used

RLY1 & RLY2 relay 1 and relay 2

X3 TERMINAL

31	NO - RL1	relay 1 dry contact max. rating 1A @ 230 VAC
32	NO - RL1	relay 1 dry contact max. rating 1A @ 230 VAC

Electrical wirings

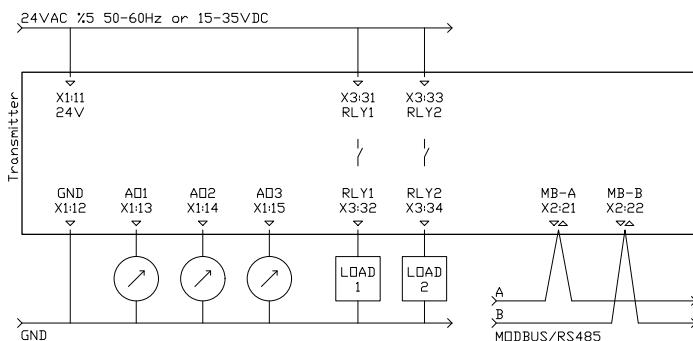

Relay contact rating is max. 1A at 230 VAC. We kindly advise using 24 VAC for avoiding high voltage harmonics and external power relay for bigger loads. Please use shielded and twisted paired cables for Modbus connections.



■ Display & Buttons

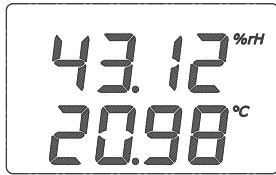
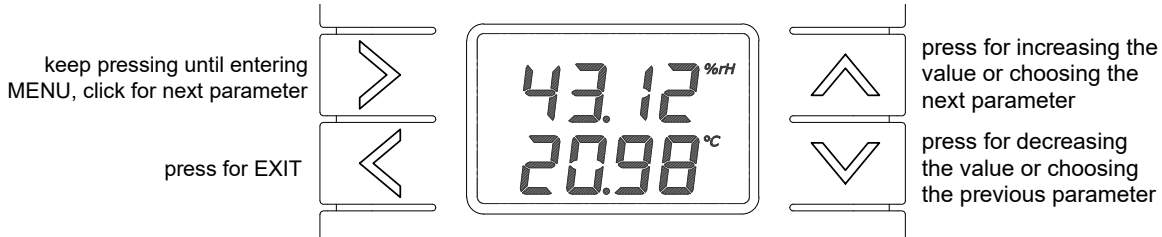

main screen
transmitter is working

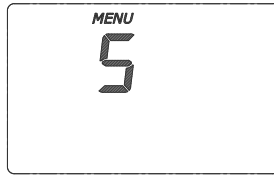

keep pressing MENU button until seeing 0
transmitter is not working in MENU mode

■ Parameters for Relay & Buzzer

Main Screen >>>> r1 L > r1 H > r1 A > Main Screen

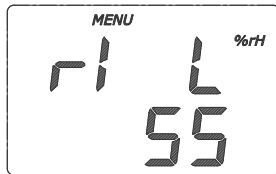

LOW set point for Relay

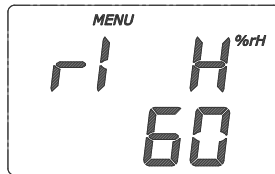

HIGH set point for Relay

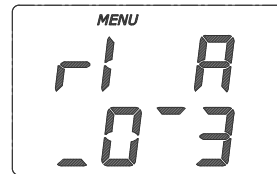

ACTION selection for Relay

■ Actions for Relay & Buzzer



action 0,
relay contact is always OPEN
buzzer is always SILENCE

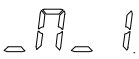

action 1,
relay contact is CLOSED between points, OPEN under LOWpoint and OPEN over HIGHpoint
buzzer is WARNING between points, SILENCE under LOWpoint and SILENCE over HIGHpoint



action 2,
relay contact is OPEN between points, CLOSED under LOWpoint and OPEN over HIGHpoint
buzzer is SILENCE between points, WARNING under LOWpoint and SILENCE over HIGHpoint

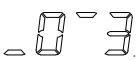

action 3,
relay contact is CLOSED over HIGHpoint, OPEN under LOWpoint, hysteresis between points
buzzer is WARNING over HIGHpoint, SILENCE under LOWpoint, hysteresis between points

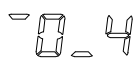

action 4,
relay contact is OPEN over HIGHpoint, CLOSED under LOWpoint, hysteresis between points
buzzer is SILENCE over HIGHpoint, WARNING under LOWpoint, hysteresis between points



ACTIONS	under LOW	between LOW & HIGH	over HIGH
0 : 0.0.0	Open	Open	Open
1 : 0.1.0	Open	Closed	Open
2 : 1.0.1	Closed	Open	Closed
3 : 0.X.1	Open	Hysteresis	Closed
4 : 1.X.0	Closed	Hysteresis	Open

0 : Relay Contact is OPEN, Buzzer is in Silent mode

1 : Relay Contact is CLOSED, Buzzer is in Warning mode

X : Relay Contact is at HYSTERESIS position, OPEN if previous position open, CLOSED if previous position closed

Modbus RS485 protocol

Default Settings: Modbus ID:1, 9600, 8bit, None, 1. Register Table starts from Base 1.

Use Function 3 for Reading and Function 6 for Writing Holding Registers. Whenever writing to any Modbus Parameter, new parameter is activated instantly and you should have to configure master device according to new parameters. For every reboot/initializing, Modbus is activated with default parameters for 3 seconds. After 3seconds, Modbus is reconfigured according your parameter settings.

Unlisted registers are for analog output calibrations and some system parameters. Please do not change unlisted registers.

Register	R/W	Range	Description
1	R & W	1...254	Modbus Address
2	R & W	0...4	Baudrate, 0: 9.600, 1: 19.200, 2: 38.400, 3: 57.600, 4: 115.200
3	R & W	0...3	Bit_Parity_Stop, 0: 8bit_None_1, 1: 8bit_None_2, 2: 8bit_Even_1, 3: 8bit_Odd_1
4	R		Humidity as %RH x10, divide by 10 for exact value
5	R		Temperature as C x10, divide by 10 for exact value
6	R	0 or 1	Relay 1, contact position, 0: OFF - Contact is Open, 1: ON - Contact is Closed
7	R	0...1.000	Relay 1, LOW point
8	R	0...1.000	Relay 1, HIGH point
9	R	0...4	Relay 1, ACTION
10	R	0 or 1	Relay 2, contact position, 0: OFF - Contact is Open, 1: ON - Contact is Closed
11	R	0...1.000	Relay 2, LOW point
12	R	0...1.000	Relay 2, HIGH point
13	R	0...4	Relay 2, ACTION
14	R	0 or 1	Buzzer, 0: OK-Silence, 1: PreAlarm - warning intermittently, 2: WARNING continuously
15	R	0...1.000	Buzzer, LOW point
16	R	0...1.000	Buzzer, HIGH point
17	R	0...4	Buzzer, ACTION
18-29	R		Only for service needs
30	R		Blank
31	R		Temperature as C x10, divide by 10 for exact value
32	R		Temperature as C
33	R		Temperature as F x10, divide by 10 for exact value
34	R		Temperature as F
35	R		Humidity as %RH x10, divide by 10 for exact value
36	R		Humidity as %RH



■ Dimensions (mm)

without relay

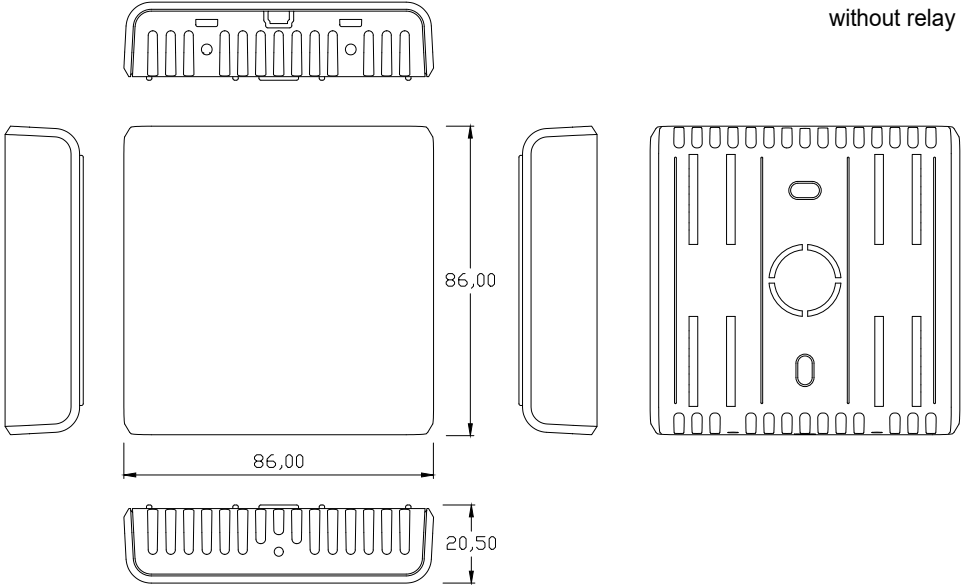

with relay

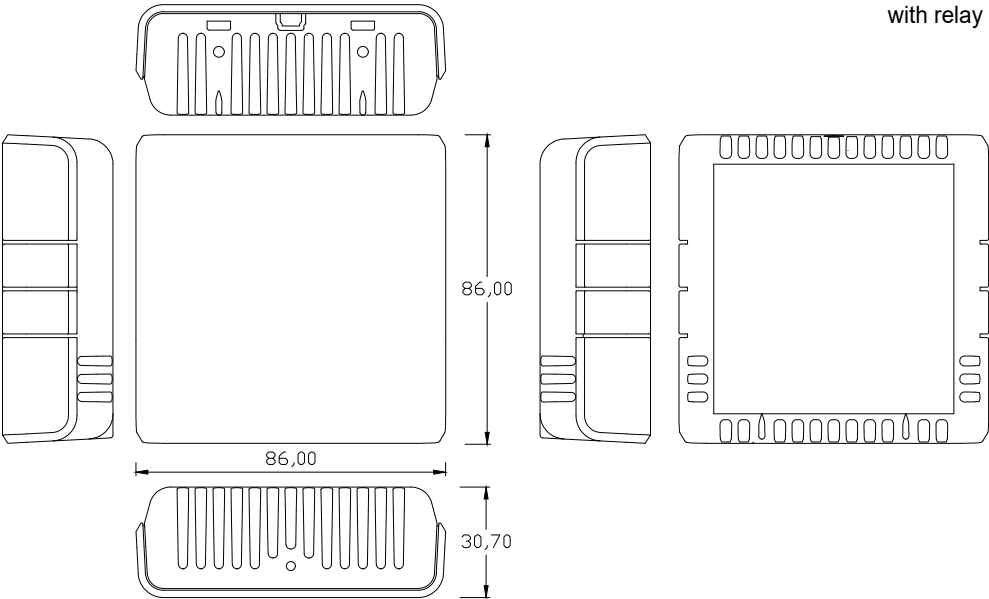



Description

The outdoor temperature/humidity transmitter serie KTO measures the temperature and humidity by capacitive sensors and converts the value into a linear output signal 0...10 VDC or 4...20 mA.

Technical specifications

Measurement range RH	0...100 % RH
Accuracy RH	2 % RH
Measurement range °C	0...50°C, 0...100°C, -30...+70°C, -40...+60°C
Accuracy °C	0,5°C
Power supply	24 VAC (±5%) 50-60 Hz / 15...35 VDC
Power consumption	< 2,5 W
Working resistance at 0...10 VDC	min. 1 kOhm
Working resistance at 4...20 mA	max 500 Ohm
Electrical connection	Screw terminals max. 1,5 mm ²
Housing	ABS
Dimensions	See drawing
Protection type	IP41
Working range RH	0...98% RH in contaminant-free, non-condensing air
Working temperature °C	-30...+80°C
Standards	CE conformity, RoHS



Order matrix

Model	Accuracy	Output 1 Humidity		Output 2 - Temperature		Option	
KTO	2 %RH	0	no output	0	no output	M	Modbus
		1	0...10 V	1	0...10 V	D	Display
		2	2...10 V	2	2...10 V	R	Relay*
		3	0...5 V	3	0...5 V		
		4	1...5 V	4	1...5 V		
		5	4...20 mA	5	4...20 mA		

* The relay option is available only with display.

DIP Switch

DIP	Temp. Ranges
	0...50°C
	0...100°C
	-30...+70°C
	-40...+60°C

DIP	Response
	1 sec.
	5 sec.
	10 sec.
	30 sec.



Transmitter hardware

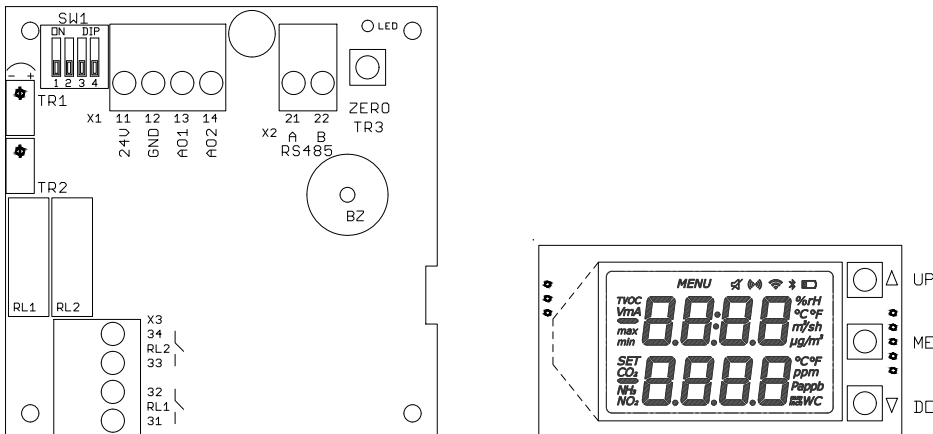

SW1 DIP Switch for configuration range and response time

X1 TERMINAL

11	24V	15...35 VDC or 24 VAC (\pm %5, 50-60 Hz)
12	GND	ground for power and reference for outputs
13	AO1	analog output 1
14	AO2	analog output 2

X2 TERMINAL

21	A / RS485	modbus communication positive pair
22	B / RS485	modbus communication negative pair

LED bead LED, periodically lights ON and OFF
modbus communication, blinks when there is a communication

TR1 not used

TR2 not used

ZERO / TR3 not used

RL1 & RL2 relay 1 and relay 2

BZ buzzer

X3 TERMINAL

31	NO - RL1	relay 1 dry contact max. rating 1A @ 230 VAC
32	NO - RL1	relay 1 dry contact max. rating 1A @ 230 VAC

Electrical wirings

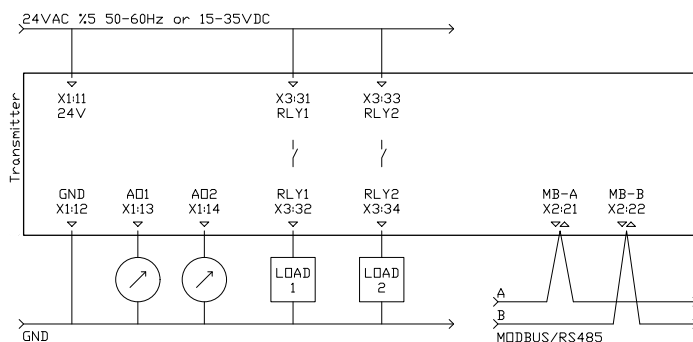

Relay contact rating is max. 1A at 230 VAC.
We kindly advise using 24 VAC for avoiding high voltage harmonics and external power relay for bigger loads.
Please use shielded and twisted paired cables for Modbus connections.



Display & Buttons

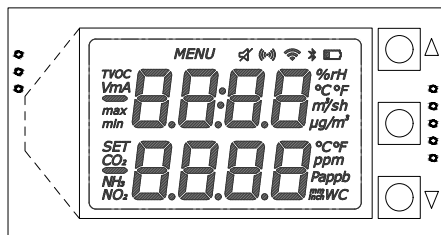

- UP press for increasing the value or choosing the next parameter
- MENU press and wait to enter MENU, click to navigate between sub menus one by one
- DOWN press for decreasing the value or choosing the previous parameter

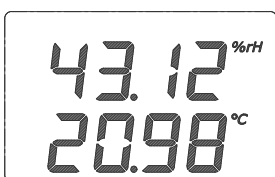

main screen
transmitter is working

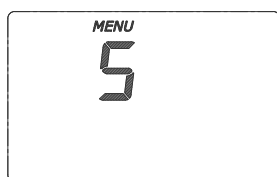

keep pressing MENU button until seeing 0
transmitter is not working in MENU mode

Parameters for Relay & Buzzer

Main Screen >>>> r1 L > r1 H > r1 A > Main Screen

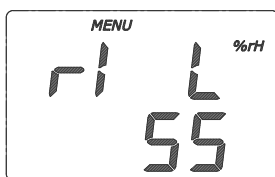

LOW set point for Relay

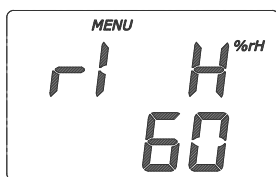

HIGH set point for Relay

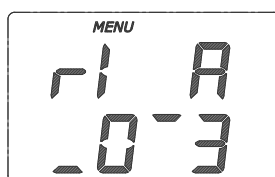

ACTION selection for Relay

Actions for Relay & Buzzer



action 0,
relay contact is always OPEN
buzzer is always SILENCE

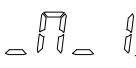

action 1,
relay contact is CLOSED between points, OPEN under LOWpoint and OPEN over HIGHpoint
buzzer is WARNING between points, SILENCE under LOWpoint and SILENCE over HIGHpoint



action 2,
relay contact is OPEN between points, CLOSED under LOWpoint and OPEN over HIGHpoint
buzzer is SILENCE between points, WARNING under LOWpoint and SILENCE over HIGHpoint

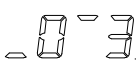

action 3,
relay contact is CLOSED over HIGHpoint, OPEN under LOWpoint, hysteresis between points
buzzer is WARNING over HIGHpoint, SILENCE under LOWpoint, hysteresis between points

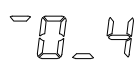

action 4,
relay contact is OPEN over HIGHpoint, CLOSED under LOWpoint, hysteresis between points
buzzer is SILENCE over HIGHpoint, WARNING under LOWpoint, hysteresis between points



ACTIONS	under LOW	between LOW & HIGH	over HIGH
0 : 0.0.0	Open	Open	Open
1 : 0.1.0	Open	Closed	Open
2 : 1.0.1	Closed	Open	Closed
3 : 0.X.1	Open	Hysteresis	Closed
4 : 1.X.0	Closed	Hysteresis	Open

0 : Relay Contact is OPEN, Buzzer is in Silent mode

1 : Relay Contact is CLOSED, Buzzer is in Warning mode

X : Relay Contact is at HYSTERESIS position, OPEN if previous position open, CLOSED if previous position closed

Modbus RS485 protocol

Default Settings: Modbus ID:1, 9600, 8bit, None, 1. Register Table starts from Base 1.

Use Function 3 for Reading and Function 6 for Writing Holding Registers. Whenever writing to any Modbus Parameter, new parameter is activated instantly and you should have to configure master device according to new parameters. For every reboot/initializing, Modbus is activated with default parameters for 3 seconds. After 3seconds, Modbus is reconfigured according your parameter settings.

Unlisted registers are for analog output calibrations and some system parameters. Please do not change unlisted registers.

Register	R/W	Range	Description
1	R & W	1...254	Modbus Address
2	R & W	0...4	Baudrate, 0: 9.600, 1: 19.200, 2: 38.400, 3: 57.600, 4: 115.200
3	R & W	0...3	Bit_Parity_Stop, 0: 8bit_None_1, 1: 8bit_None_2, 2: 8bit_Even_1, 3: 8bit_Odd_1
4	R		Humidity as %rH x10, divide by 10 for exact value
5	R		Temperature as C x10, divide by 10 for exact value
6	R	0 or 1	Relay 1, contact position, 0: OFF - Contact is Open, 1: ON - Contact is Closed
7	R	0...1.000	Relay 1, LOW point
8	R	0...1.000	Relay 1, HIGH point
9	R	0...4	Relay 1, ACTION
10	R	0 or 1	Relay 2, contact position, 0: OFF - Contact is Open, 1: ON - Contact is Closed
11	R	0...1.000	Relay 2, LOW point
12	R	0...1.000	Relay 2, HIGH point
13	R	0...4	Relay 2, ACTION
14	R	0 or 1	Buzzer, 0: OK-Silence, 1: PreAlarm - warning intermittently, 2: WARNING continuously
15	R	0...1.000	Buzzer, LOW point
16	R	0...1.000	Buzzer, HIGH point
17	R	0...4	Buzzer, ACTION
18-29	R		Only for service needs
30	R		Blank
31	R		Temperature as C x10, divide by 10 for exact value
32	R		Temperature as C
33	R		Temperature as F x10, divide by 10 for exact value
34	R		Temperature as F
35	R		Humidity as %RH x10, divide by 10 for exact value
36	R		Humidity as %RH



■ Dimensions (mm)

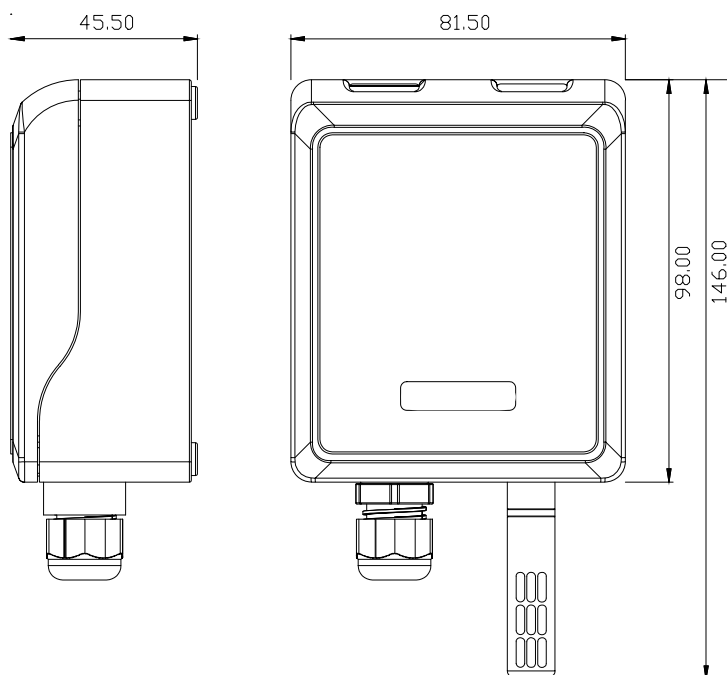



Description

The duct temperature/humidity transmitter serie KTD measures the temperature and humidity by capacitive sensors and converts the value into a linear output signal 0...10 VDC or 4...20 mA.

Technical specifications

Measurement range RH	0...100 % RH
Accuracy RH	2 % RH
Measurement range °C	0...50°C, 0...100°C, -30...+70°C, -40...+60°C
Accuracy °C	0,5°C
Power supply	24 VAC (±5%) 50-60 Hz / 15...35 VDC
Power consumption	< 2,5 W
Working resistance at 0...10 VDC	min. 1 kOhm
Working resistance at 4...20 mA	max 500 Ohm
Electrical connection	Screw terminals max. 1,5 mm ²
Housing	ABS
Dimensions	See drawing
Protection type	IP41
Working range RH	0...98% RH in contaminant-free, non-condensing air
Working temperature °C	-30...+80°C
Standards	CE conformity, RoHS



Order matrix

Model	Accuracy	Output 1 Humidity		Output 2 Temperature		Option	
KTD	2 %RH	0	no output	0	no output	M	Modbus
		1	0...10 V	1	0...10 V	D	Display
		2	2...10 V	2	2...10 V	R	Relay*
		3	0...5 V	3	0...5 V		
		4	1...5 V	4	1...5 V		
		5	4...20 mA	5	4...20 mA		

* The relay option is available only with display.

DIP Switch

DIP	Temp. Ranges
	0...50°C
	0...100°C
	-30...+70°C
	-40...+60°C

DIP	Response
	1 sec.
	5 sec.
	10 sec.
	30 sec.



Transmitter hardware

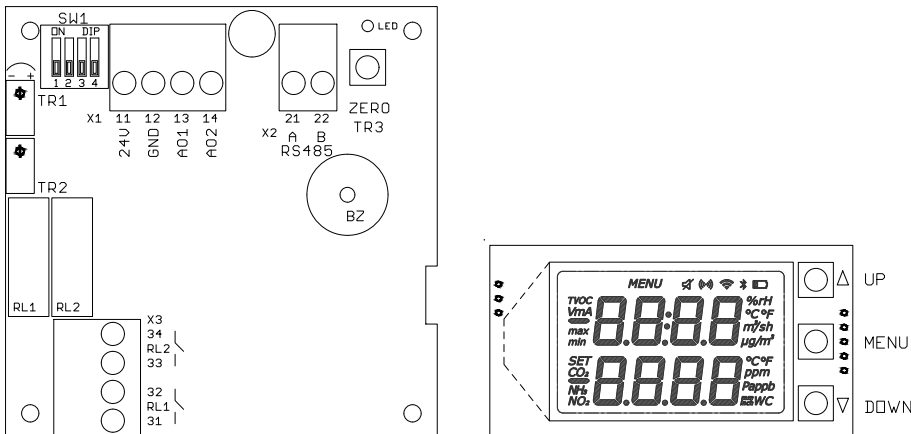

SW1	DIP Switch for configuration range and response time	
X1 TERMINAL		
11	24V	15...35 VDC or 24 VAC (± %5, 50-60 Hz)
12	GND	ground for power and reference for outputs
13	AO1	analog output 1
14	AO2	analog output 2
X2 TERMINAL		
21	A / RS485	modbus communication positive pair
22	B / RS485	modbus communication negative pair
LED	bead LED, periodically lights ON and OFF modbus communication, blinks when there is a communication	
TR1	not used	
TR2	not used	
ZERO / TR3	not used	
RL1	relay 1	
BZ	buzzer	
X3 TERMINAL		
31	NO - RL1	relay 1 dry contact max. rating 1A @ 230 VAC
32	NO - RL1	relay 1 dry contact max. rating 1A @ 230 VAC

Electrical wirings

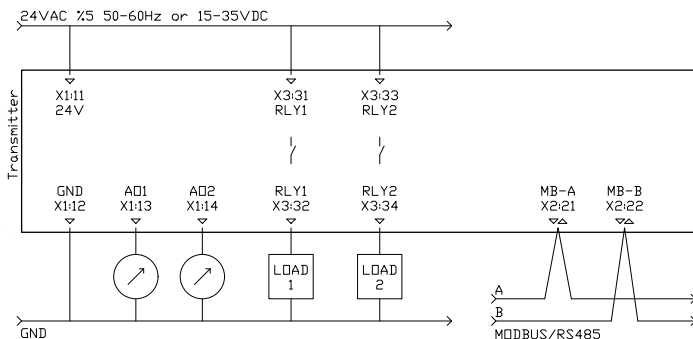

Relay contact rating is max. 1A at 230 VAC.
We kindly advise using 24 VAC for avoiding high voltage harmonics and external power relay for bigger loads.
Please use shielded and twisted paired cables for Modbus connections.



Display & Buttons

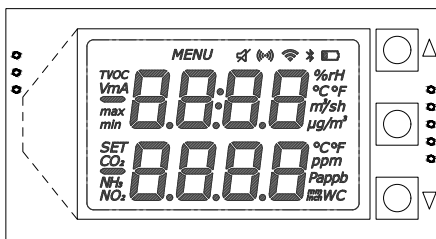

- UP press for increasing the value or choosing the next parameter
- MENU press and wait to enter MENU, click to navigate between sub menus one by one
- DOWN press for decreasing the value or choosing the previous parameter



main screen
transmitter is working

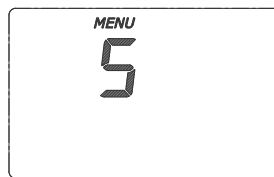

keep pressing MENU button until seeing 0
transmitter is not working in MENU mode

Parameters for Relay & Buzzer

Main Screen >>>> r1 L > r1 H > r1 A > Main Screen

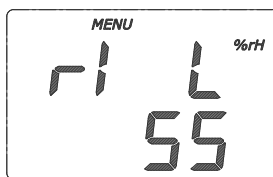

LOW set point for Relay

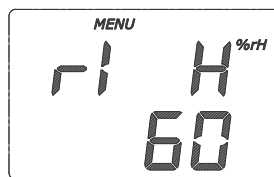

HIGH set point for Relay

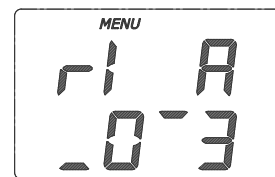

ACTION selection for Relay

Actions for Relay & Buzzer



action 0,
relay contact is always OPEN
buzzer is always SILENCE

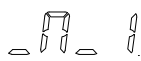

action 1,
relay contact is CLOSED between points, OPEN under LOWpoint and OPEN over HIGHpoint
buzzer is WARNING between points, SILENCE under LOWpoint and SILENCE over HIGHpoint



action 2,
relay contact is OPEN between points, CLOSED under LOWpoint and OPEN over HIGHpoint
buzzer is SILENCE between points, WARNING under LOWpoint and SILENCE over HIGHpoint

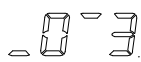

action 3,
relay contact is CLOSED over HIGHpoint, OPEN under LOWpoint, hysteresis between points
buzzer is WARNING over HIGHpoint, SILENCE under LOWpoint, hysteresis between points

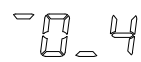

action 4,
relay contact is OPEN over HIGHpoint, CLOSED under LOWpoint, hysteresis between points
buzzer is SILENCE over HIGHpoint, WARNING under LOWpoint, hysteresis between points



ACTIONS	under LOW	between LOW & HIGH	over HIGH
0 : 0.0.0	Open	Open	Open
1 : 0.1.0	Open	Closed	Open
2 : 1.0.1	Closed	Open	Closed
3 : 0.X.1	Open	Hysteresis	Closed
4 : 1.X.0	Closed	Hysteresis	Open

0 : Relay Contact is OPEN, Buzzer is in Silent mode

1 : Relay Contact is CLOSED, Buzzer is in Warning mode

X : Relay Contact is at HYSTERESIS position, OPEN if previous position open, CLOSED if previous position closed

Modbus RS485 protocol

Default Settings: Modbus ID:1, 9600, 8bit, None, 1. Register Table starts from Base 1.

Use Function 3 for Reading and Function 6 for Writing Holding Registers. Whenever writing to any Modbus Parameter, new parameter is activated instantly and you should have to configure master device according to new parameters. For every reboot/initializing, Modbus is activated with default parameters for 3 seconds. After 3seconds, Modbus is reconfigured according your parameter settings.

Unlisted registers are for analog output calibrations and some system parameters. Please do not change unlisted registers.

Register	R/W	Range	Description
1	R & W	1...254	Modbus Address
2	R & W	0...4	Baudrate, 0: 9.600, 1: 19.200, 2: 38.400, 3: 57.600, 4: 115.200
3	R & W	0...3	Bit_Parity_Stop, 0: 8bit_None_1, 1: 8bit_None_2, 2: 8bit_Even_1, 3: 8bit_Odd_1
4	R		Humidity as %rH x10, divide by 10 for exact value
5	R		Temperature as C x10, divide by 10 for exact value
6	R	0 or 1	Relay 1, contact position, 0: OFF - Contact is Open, 1: ON - Contact is Closed
7	R	0...1.000	Relay 1, LOW point
8	R	0...1.000	Relay 1, HIGH point
9	R	0...4	Relay 1, ACTION
10	R	0 or 1	Relay 2, contact position, 0: OFF - Contact is Open, 1: ON - Contact is Closed
11	R	0...1.000	Relay 2, LOW point
12	R	0...1.000	Relay 2, HIGH point
13	R	0...4	Relay 2, ACTION
14	R	0 or 1	Buzzer, 0: OK-Silence, 1: PreAlarm - warning intermittently, 2: WARNING continuously
15	R	0...1.000	Buzzer, LOW point
16	R	0...1.000	Buzzer, HIGH point
17	R	0...4	Buzzer, ACTION
18-29	R		Only for service needs
30	R		Blank
31	R		Temperature as C x10, divide by 10 for exact value
32	R		Temperature as C
33	R		Temperature as F x10, divide by 10 for exact value
34	R		Temperature as F
35	R		Humidity as %RH x10, divide by 10 for exact value
36	R		Humidity as %RH



■ Dimensions (mm)

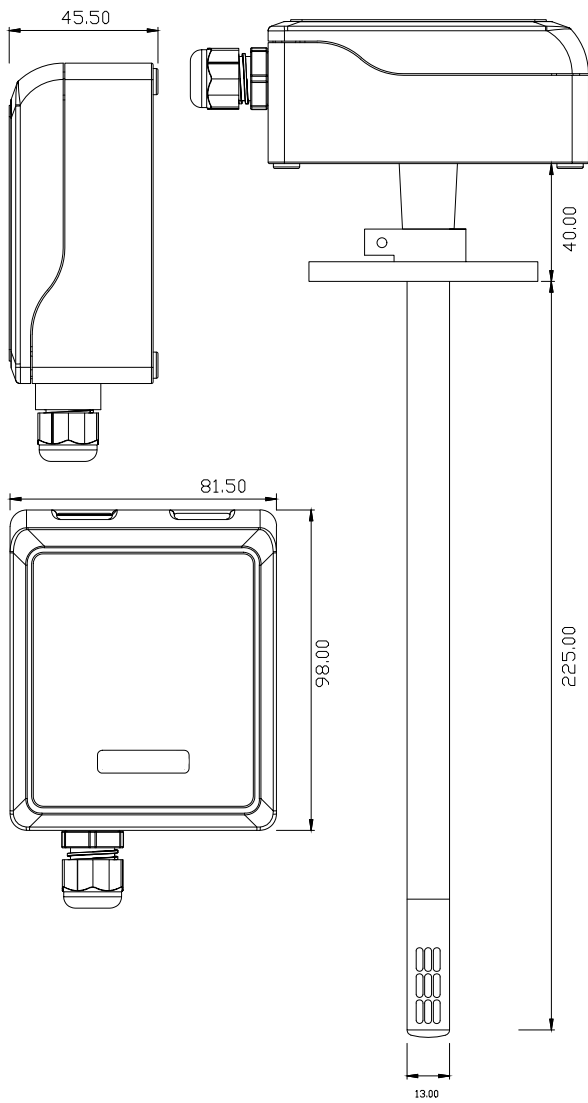



Description

The KTP series temperature and humidity transmitter with cable measures temperature and humidity in air ducts and provides a linear output signal of 0...10 V DC, 4...20 mA or RS485 (Modbus).

Technical specifications

Measurement range RH	0...100 % RH
Accuracy RH	±2% RH
Measurement range °C	-40...+100°C, to be determined upon order
Accuracy °C	±0,5°C
Power supply	24 VAC (±5%) 50-60 Hz / 14...35 VDC
Power consumption	< 1,5 W
Working resistance at 0...10 VDC	min. 1 kOhm
Working resistance at 4...20 mA	max 500 Ohm
Electrical connection	pre-wired cable, 4 x 0,34 mm ² or 6 x 0,25 mm ² length approx. 0,90 m
Housing	ABS
Dimensions	See drawing
Protection type	IP65
Working range RH	0...100% RH in contaminant-free, non-condensing air
Working temperature °C	-25...+70°C
Standards	CE conformity, RoHS, EMC: EN 61326-1



Order matrix

Model	Accuracy	Output 1 Humidity	Output 2 Temperature	Option
KTP	2 %RH		0 no	M Modbus
		1 0...10 V	1 0...10 V	
		2 2...10 V	2 2...10 V	
		3 0...5 V	3 0...5 V	
		4 1...5 V	4 1...5 V	
		5 4...20 mA	5 4...20 mA	

Output 1 is reserved for humidity, output 2 for either humidity or temperature. Specify the temperature range when ordering.

Installation notes

- Observe maximum permissible cable lengths.
- Use shielded cables when routed parallel to power lines.
- Cable entry must face downward.
- Technical data apply to vertical installation only.
- For duct installation, keep a minimum distance of 2 m from humidifiers.



Electrical wirings

Cable Color	KTP.351	KTP.311 KTP.355	KTP.311.M KTP.355.M	KTP.300.M
Brown	Power	Power	Power	Power
White	GND	GND	GND	GND
Green	HUM. out	HUM. out	HUM. out	Modbus A
Yellow	HUM. out	TEMP. out	TEMP. out	Modbus B
Pink	n/a	n/a	Modbus A	n/a
Gray	n/a	n/a	Modbus B	n/a

Modbus RS485 protocol

Default settings: Modbus ID 1, baud rate 9600, 8 bit, no parity, 1 stop bit (8N1). The register table starts from base 1. ID 254 is a general call. Function 03 is used for reading holding registers and Function 06 for writing holding registers. Whenever a Modbus parameter is written, the new value is activated immediately and the master device must be configured according to the updated parameters. Unlisted registers are reserved for system parameters and must not be modified.

Register	R/W	Range	Description
1	R & W	1...254	Modbus Address
2	R & W	0...1	Baudrate, 0: 9.600, 1: 19.200
3	R & W	0...3	Bit_Parity_Stop, 0: 8bit_None_1, 1: 8bit_None_2, 2: 8bit_Even_1, 3: 8bit_Odd_1
4	R		Humidity as %rH x10, divide by 10 for exact value
5	R		Temperature as °C x10, divide by 10 for exact value
33	R		Temperature as °F x10, divide by 10 for exact value
39	R & W	1...30	Response, 1: 1sec ... 30: 30 sec
40	R & W	1...4	Range for Temp. out, 1: 0...50°C, 2: 0...100°C, 3: -30...+70°C, 4: -40...+60°C

Dimensions (mm)

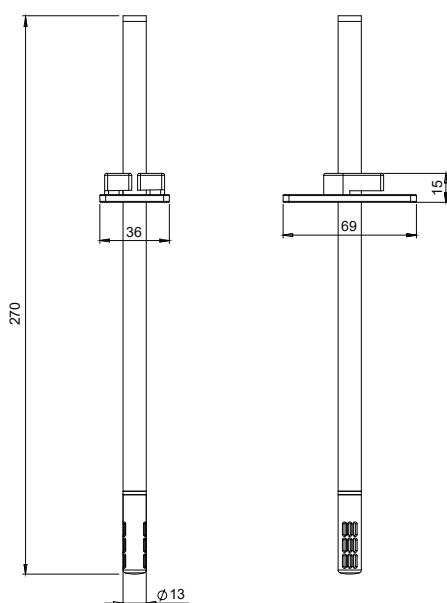



Description

The KSIC CO₂ room sensor measures air quality through the presence of carbon dioxide in the range between 0 and 10k ppm. The measurement of CO₂ concentration happens through a maintenance free NDIR sensor that operates on an infrared basis and which compensates the presence of any impurity. The product is provided different outputs.

Technical specifications

Measurement range CO₂	400...2000, 0...2k, 0...5k, 0...10k ppm selectable
Accuracy CO₂	± 70 ppm +3% reading
Accuracy temperature (*)	±0,3°C (5...60°C) + 1% FS
Accuracy humidity (*)	±2% RH (20...80%RH) + 2% FS
Power supply	24 VAC (±5%), 15...35 VDC
Consumption	< 2,5 W
Sensible element	NDIR self adjusting
Output	0...5 VDC, 0...10 VDC, 4...20 mA, Modbus 485
Electrical connection	Pluggable screw terminal for cables 1,5 mm ²
Protection type	IP41
Working range RH	10...95% RH in contaminant-free, non-condensing air
Working temperature °C	-30...+70°C
Storage temperature	-20...+50°C
Standards	CE conformity, RoHS



Order matrix

Model	Output 1 CO ₂	Output 2 Temperature	Output 3 Humidity	Option
KSIC	0 no output	0 no output	0 no output	M Modbus
	1 0...10 V	1 0...10 V	1 0...10 V	D Display
	2 2...10 V	2 2...10 V	2 2...10 V	R Relay*
	3 0...5 V	3 0...5 V	3 0...5 V	
	4 1...5 V	4 1...5 V	4 1...5 V	
	5 4...20 mA	5 4...20 mA	5 4...20 mA	

* The relay option is available only with display.

DIP Switch

DIP 1-2	CO2 Ranges	DIP 4	Response
	400-2.000 ppm		60 sec.
	0-2.000 ppm		20 sec.
	0-5.000 ppm		
	0-10.000 ppm		



Transmitter hardware

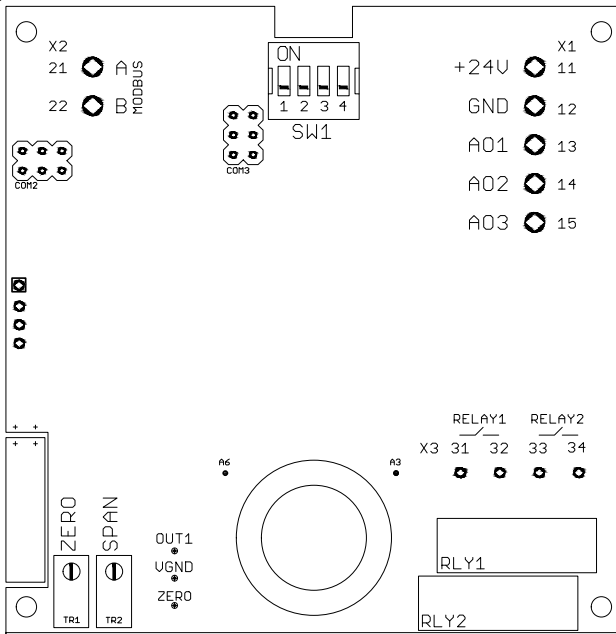

SW1 DIP Switch for configuration range and response time

X1 TERMINAL

11	24V	15...35 VDC or 24 VAC (\pm %5, 50-60 Hz)
12	GND	ground for power and reference for outputs
13	AO1	analog output 1
14	AO2	analog output 2
15	AO3	analog output 3

X2 TERMINAL

21	A / RS485	modbus communication positive pair
22	B / RS485	modbus communication negative pair

RLY1 & RLY2 relay 1 and relay 2

X3 TERMINAL

31	NO - RL1	relay 1 dry contact max. rating 1A @ 230 VAC
32	NO - RL1	relay 1 dry contact max. rating 1A @ 230 VAC

Electrical wirings

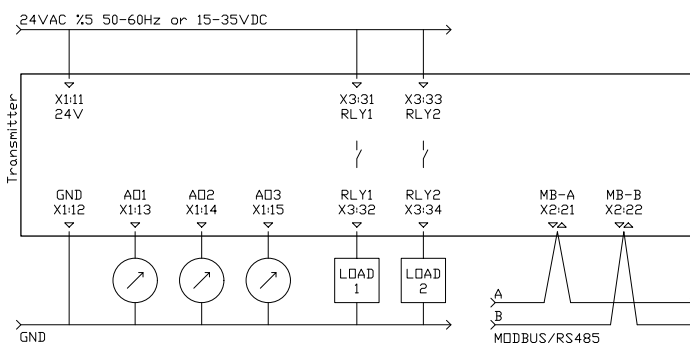

Relay contact rating is max. 1A at 230 VAC
 We kindly advise using 24V for avoiding high voltage harmonics and external power relay for bigger loads
 Please use shielded and twisted paired cables for Modbus connections



Display & Buttons

keep pressing until entering MENU, click for next parameter

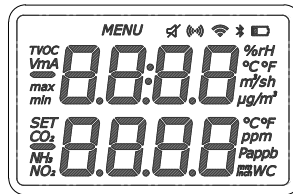

press for increasing the value or choosing the next parameter

press for EXIT



press for decreasing the value or choosing the previous parameter

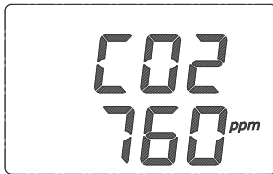

main screen
transmitter is working



keep pressing MENU button until seeing 0
transmitter is not working in MENU mode

Parameters for Relay & Buzzer

Main Screen >>>> r1 L > r1 H > r1 A > Main Screen

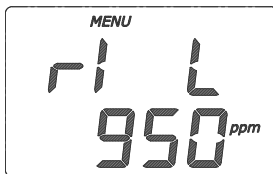

LOW set point for Relay 1

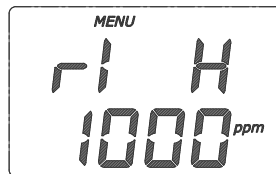

HIGH set point for Relay 1

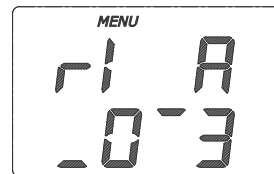

ACTION selection for Relay 1

Actions for Relay & Buzzer



action 0,
relay contact is always OPEN



action 1,
relay contact is CLOSED between points, OPEN under LOWpoint and OPEN over HIGHpoint



action 2,
relay contact is OPEN between points, CLOSED under LOWpoint and OPEN over HIGHpoint

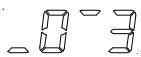

action 3,
relay contact is CLOSED over HIGHpoint, OPEN under LOWpoint, hysteresis between points

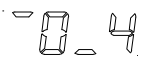

action 4,
relay contact is OPEN over HIGHpoint, CLOSED under LOWpoint, hysteresis between points



ACTIONS	under LOW	between LOW & HIGH	over HIGH
0 : 0.0.0	Open	Open	Open
1 : 0.1.0	Open	Closed	Open
2 : 1.0.1	Closed	Open	Closed
3 : 0.X.1	Open	Hysteresis	Closed
4 : 1.X.0	Closed	Hysteresis	Open

0 : Relay Contact is OPEN, Buzzer is in Silent mode

1 : Relay Contact is CLOSED, Buzzer is in Warning mode

X : Relay Contact is at HYSTERESIS position, OPEN if previous position open, CLOSED if previous position closed

Modbus RS485 protocol

Default Settings: Modbus ID:1, 9600, 8bit, None, 1. Register Table starts from Base 1.

Use Function 3 for Reading and Function 6 for Writing Holding Registers. Whenever writing to any Modbus Parameter, new parameter is activated instantly and you should have to configure master device according to new parameters. For every reboot/initializing, Modbus is activated with default parameters for 3 seconds. After 3 seconds, Modbus is reconfigured according your parameter settings.

Unlisted registers are for analog output calibrations and some system parameters. Please do not change unlisted registers.

Register	R/W	Range	Description
1	R & W	1...254	Modbus Address
2	R & W	0...4	Baudrate, 0: 9.600, 1: 19.200, 2: 38.400, 3: 57.600, 4: 115.200
3	R & W	0...3	Bit_Parity_Stop, 0: 8bit_None_1, 1: 8bit_None_2, 2: 8bit_Even_1, 3: 8bit_Odd_1
4	R		CO2 level as ppm
5	R		Temperature as C x100, divide by 100 for exact value
6	R	0 or 1	Relay 1, contact position, 0: OFF - Contact is Open, 1: ON - Contact is Closed
7	R	0...1.000	Relay 1, LOW point
8	R	0...1.000	Relay 1, HIGH point
9	R	0...4	Relay 1, ACTION
10	R	0 or 1	Relay 2, contact position, 0: OFF - Contact is Open, 1: ON - Contact is Closed
11	R	0...1.000	Relay 2, LOW point
12	R	0...1.000	Relay 2, HIGH point
13	R	0...4	Relay 2, ACTION
14	R	0 or 1	Buzzer, 0: OK-Silence, 1: PreAlarm - warning intermittently, 2: WARNING continuously
15	R	0...1.000	Buzzer, LOW point
16	R	0...1.000	Buzzer, HIGH point
17	R	0...4	Buzzer, ACTION
18-29	R		Only for service needs
30	R		CO2 level as ppm
31	R		Temperature as C x100, divide by 100 for exact value
32	R		Temperature as C
33	R		Temperature as F x100, divide by 100 for exact value
34	R		Temperature as F
35	R		Humidity as %rH x100, divide by 100 for exact value
36	R		Humidity as %rH



■ Dimensions (mm)

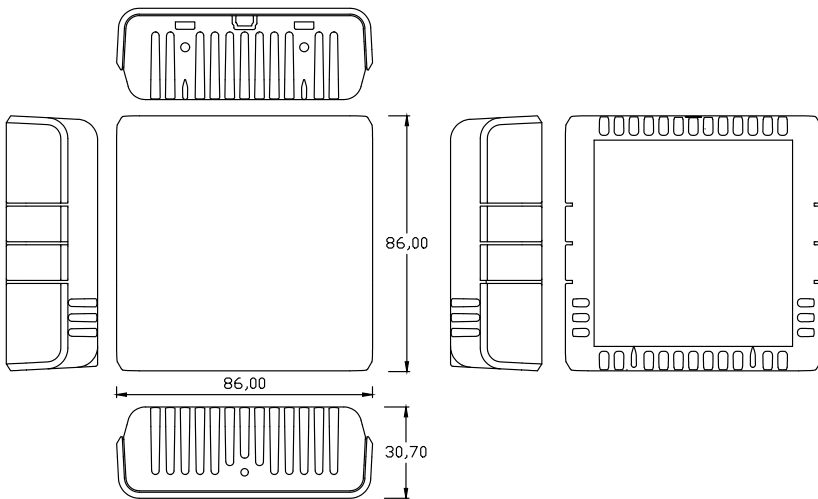
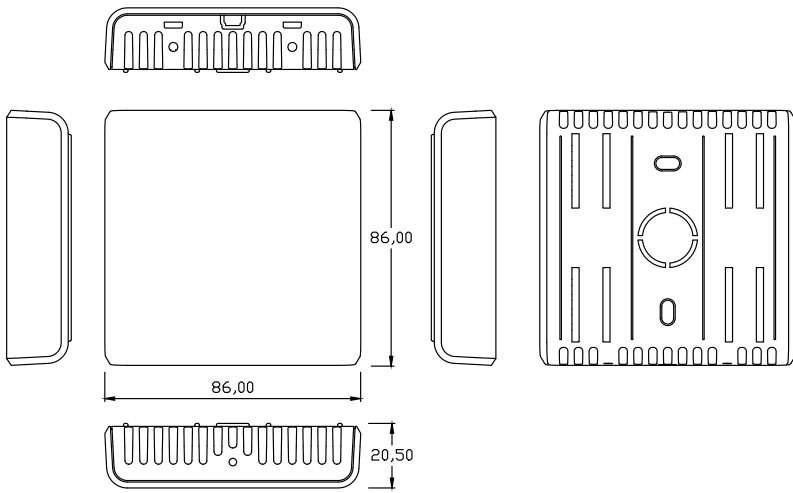



Description

The KSDC CO₂ sensor measures air quality through the presence of carbon dioxide in air ducts in the range between 0 and 10k ppm. The measurement of CO₂ concentration happens through a maintenance free NDIR sensor that operates on an infrared basis and which compensates the presence of any impurity. The product is provided different outputs.

Technical specifications

Measurement range CO₂	400...2000, 0...2k, 0...5k, 0...10k ppm selectable
Accuracy CO₂	± 70 ppm +3% reading
Accuracy temperature (*)	±0,3°C (5...60°C) + 1% FS
Accuracy humidity (*)	±2% RH (20...80%RH) + 2% FS
Power supply	24 VAC (±5%), 15...35 VDC
Consumption	< 2,5 W
Sensible element	NDIR self adjusting
Output	0...5 VDC, 0...10 VDC, 4...20 mA, Modbus 485
Electrical connection	Pluggable screw terminal for cables 1,5 mm ²
Protection type	IP41
Working range RH	10...95% RH in contaminant-free, non-condensing air
Working temperature °C	-30...+70°C
Storage temperature	-20...+50°C
Standards	CE conformity, RoHS



Order matrix

Model	Output 1 CO ₂	Output 2 Temperature	Output 3 Humidity	Option
KSDC	0 no output	0 no output	0 no output	M Modbus
	1 0...10 V	1 0...10 V	1 0...10 V	D Display
	2 2...10 V	2 2...10 V	2 2...10 V	R Relay*
	3 0...5 V	3 0...5 V	3 0...5 V	
	4 1...5 V	4 1...5 V	4 1...5 V	
	5 4...20 mA	5 4...20 mA	5 4...20 mA	

* The relay option is available only with display.

DIP Switch

DIP 1-2	CO2 Ranges	DIP 4	Response
	400-2.000 ppm		60 sec.
	0-2.000 ppm		20 sec.
	0-5.000 ppm		
	0-10.000 ppm		



Transmitter hardware

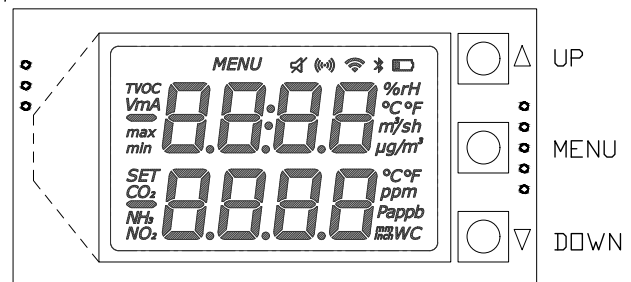
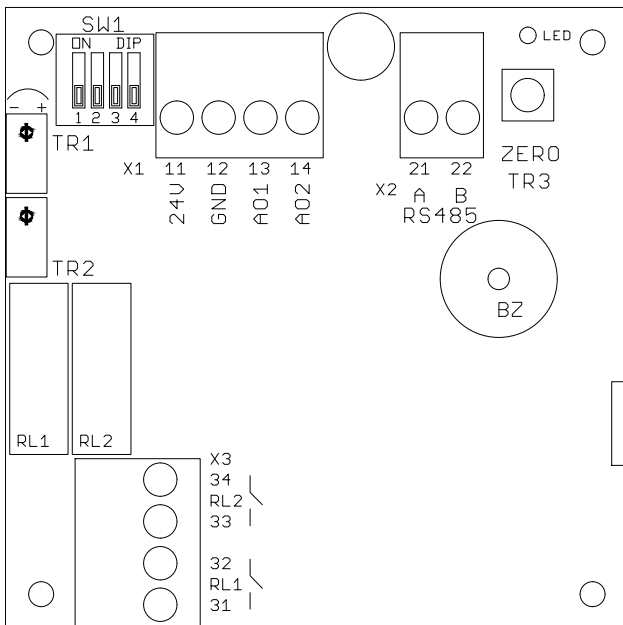

- SW1** DIP Switch for configuration range and response time
- X1 TERMINAL**
- 11 24V 15...35 VDC or 24 VAC (± %5, 50-60 Hz)
- 12 GND ground for power and reference for outputs
- 13 AO1 analog output 1
- 14 AO2 analog output 2
- X2 TERMINAL**
- 21 A / RS485 modbus communication positive pair
- 22 B / RS485 modbus communication negative pair
- LED** bead LED, periodically lights ON and OFF
modbus communication, blinks when there is a communication
- TR1** not used
- TR2** not used
- ZERO / TR3** not used
- RL1** relay 1
- BZ** buzzer
- X3 TERMINAL**
- 31 NO - RL1 relay 1 dry contact max. rating 1A @ 230 VAC
- 32 NO - RL1 relay 1 dry contact max. rating 1A @ 230 VAC

Electrical wirings

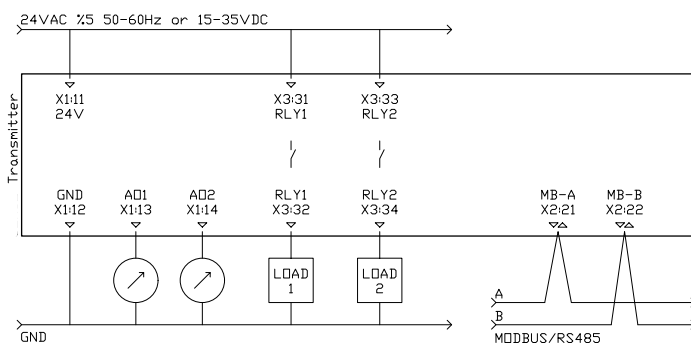

Relay contact rating is max. 1A at 230 VAC
 We kindly advise using 24V for avoiding high voltage harmonics and external power relay for bigger loads
 Please use shielded and twisted paired cables for Modbus connections



Display & Buttons

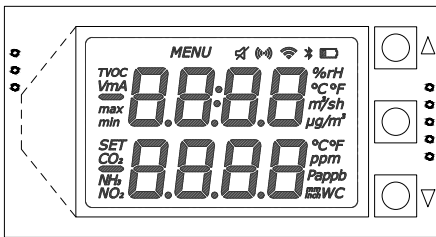

- UP press for increasing the value or choosing the next parameter
- MENU press and wait to enter MENU, click to navigate between sub menus one by one
- DOWN press for decreasing the value or choosing the previous parameter

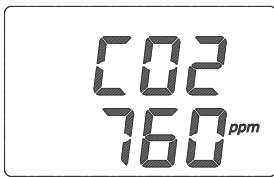

main screen
transmitter is working

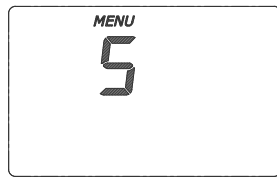

keep pressing MENU button until seeing 0
transmitter is not working in MENU mode

Parameters for Relay & Buzzer

Main Screen >>>> r1 L > r1 H > r1 A > Main Screen

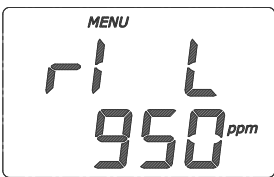

LOW set point for Relay

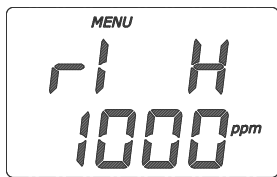

HIGH set point for Relay

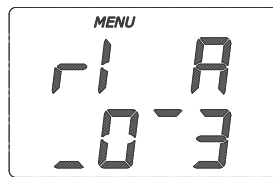

ACTION selection for Relay

Actions for Relay & Buzzer



action 0,
relay contact is always OPEN



action 1,
relay contact is CLOSED between points, OPEN under LOWpoint and OPEN over HIGHpoint



action 2,
relay contact is OPEN between points, CLOSED under LOWpoint and OPEN over HIGHpoint

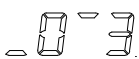

action 3,
relay contact is CLOSED over HIGHpoint, OPEN under LOWpoint, hysteresis between points

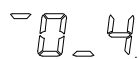

action 4,
relay contact is OPEN over HIGHpoint, CLOSED under LOWpoint, hysteresis between points



ACTIONS	under LOW	between LOW & HIGH	over HIGH
0 : 0.0.0	Open	Open	Open
1 : 0.1.0	Open	Closed	Open
2 : 1.0.1	Closed	Open	Closed
3 : 0.X.1	Open	Hysteresis	Closed
4 : 1.X.0	Closed	Hysteresis	Open

0 : Relay contact is OPEN

1 : Relay contact is CLOSED

X: Relay Contact is at HYSTERESIS position, OPEN if previous position open, CLOSED if previous position closed

Modbus RS485 protocol

Default Settings: Modbus ID:1, 9600, 8bit, None, 1. Register Table starts from Base 1.

Use Function 3 for Reading and Function 6 for Writing Holding Registers. Whenever writing to any Modbus Parameter, the new parameter is activated instantly and you should have to configure the master device according to new parameters. For every reboot/initializing, Modbus is activated with default parameters for 3 seconds. After 3 seconds, Modbus is reconfigured according to your parameter settings.

Unlisted registers are for analog output calibrations and some system parameters. Please do not change unlisted registers.

Register	R/W	Range	Description
1	R & W	1...254	Modbus Address
2	R & W	0...2	Baudrate, 0: 9.600, 1: 19.200
3	R & W	0...3	Bit_Parity_Stop, 0: 8bit_None_1, 1: 8bit_None_2, 2: 8bit_Even_1, 3: 8bit_Odd_1
4	R		CO2 level as ppm
5	R		Temperature as C x100, divide by 100 for exact value
6	R	0 or 1	Relay 1, contact position, 0: OFF - Contact is Open, 1: ON - Contact is Closed
7	R	0...1.000	Relay 1, LOW point
8	R	0...1.000	Relay 1, HIGH point
9	R	0...4	Relay 1, ACTION
10	R	0 or 1	Relay 2, contact position, 0: OFF - Contact is Open, 1: ON - Contact is Closed
11	R	0...1.000	Relay 2, LOW point
12	R	0...1.000	Relay 2, HIGH point
13	R	0...4	Relay 2, ACTION
14	R	0 or 1	Buzzer, 0: OK-Silence, 1: PreAlarm - warning intermittently, 2: WARNING continuously
15	R	0...1.000	Buzzer, LOW point
16	R	0...1.000	Buzzer, HIGH point
17	R	0...4	Buzzer, ACTION
18-29	R		Only for service needs
30	R		CO2 level as ppm
31	R		Temperature as C x100, divide by 100 for exact value
32	R		Temperature as C
33	R		Temperature as F x100, divide by 100 for exact value
34	R		Temperature as F
35	R		Humidity as %rH x100, divide by 100 for exact value
36	R		Humidity as %rH



■ Dimensions (mm)

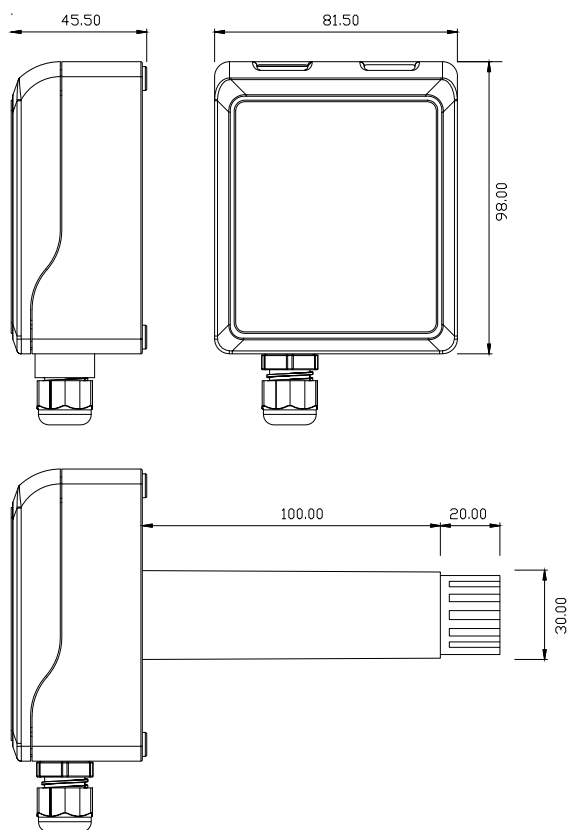

Room air quality sensor

KSAV



Description

The KSAV probe for mixed gases (VOC) measures air quality in the range 0...500. It can be supplied with a 0...10 V DC or 4...20 mA output and with an SPST-NO relay.

Technical specifications

Measurement range VOC	0...500
Accuracy VOC	±15% FS
Power supply	24 V AC (±5%), 50-60 Hz, 15...35 V DC
Consumption	<2,5 W
Relay	SPST-NO potential free
Relay contact	Max 1 A a 230 V AC
Electrical connection	Screw terminal for cables max. 1,5 mm ²
Housing	ABS (plastic) colour white
Weight	ca. 96 g
Protection type	IP41
Working range RH	0...90% RH in contaminant-free, non-condensing air
Working temperature	-10...+50°C
Standards	CE conformity, RoHS



Order matrix

Model	Output 1 CO ₂	Output 2 Temperature	Output 3 Humidity	Option
KSIC	0 no output	0 no output	0 no output	M Modbus
	1 0...10 V	1 0...10 V	1 0...10 V	D Display
	2 2...10 V	2 2...10 V	2 2...10 V	R Relay 1
	3 0...5 V	3 0...5 V	3 0...5 V	RR Relay 2
	4 1...5 V	4 1...5 V	4 1...5 V	B Buzzer
	5 4...20 mA	5 4...20 mA	5 4...20 mA	

Relay and buzzer options are available only with display.

DIP Switch

DIP 1-2	Range
	0...500
	0...400
	0...300
	0...200



Transmitter hardware

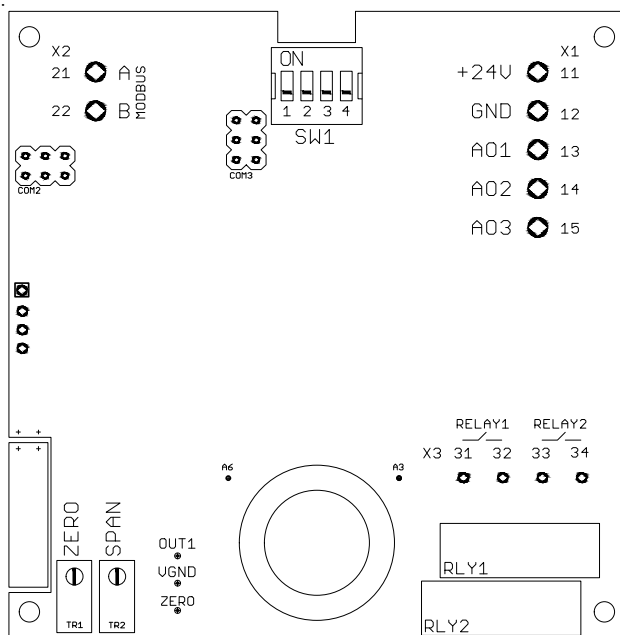

SW1 DIP Switch for configuration range and response time

X1 TERMINAL

11	24V	15...35 VDC or 24 VAC (\pm %5, 50-60 Hz)
12	GND	ground for power and reference for outputs
13	AO1	analog output 1
14	AO2	analog output 2
15	AO3	analog output 3

X2 TERMINAL

21	A / RS485	modbus communication positive pair
22	B / RS485	modbus communication negative pair

RLY1 & RLY2 relay 1 and relay 2

X3 TERMINAL

31	NO - RL1	relay 1 dry contact max. rating 1 A @ 230 V AC
32	NO - RL1	relay 1 dry contact max. rating 1 A @ 230 V AC
33	NO - RL2	relay 2 dry contact max. rating 1 A @ 230 V AC
34	NO - RL2	relay 2 dry contact max. rating 1 A @ 230 V AC

Electrical wirings

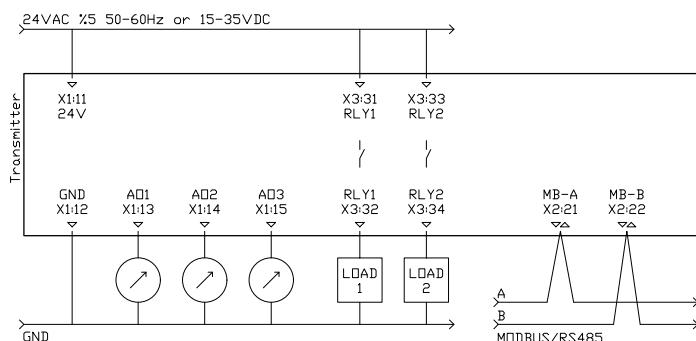

Relay contact rating is max. 1 A at 230 V AC
We kindly advise using 24 V AC for avoiding high voltage harmonics and external power relay for bigger loads.
Please use shielded and twisted paired cables for Modbus connections.



Display



main screen
transmitter is working



keep pressing MENU button until seeing SET
transmitter is not working in MENU mode

Parameters for relay and buzzer

Main Screen >>>> r1 L > r1 H > r1 A > r2 L > r2 H > r2 A > B L > B H > B A > Main Screen

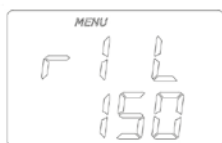

LOW set point
for relay 1

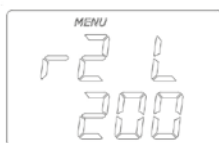

LOW set point
for relay 2

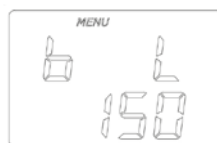

LOW set point
for buzzer

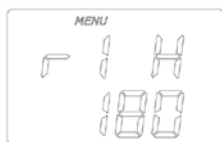

HIGH set point
for relay 1

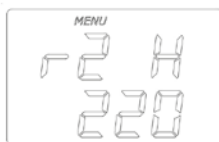

HIGH set point
for relay 2

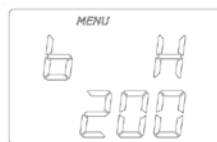

HIGH set point
for buzzer

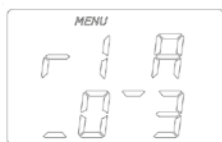

ACTION selection
for relay 1

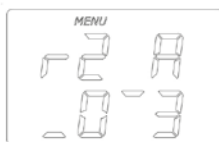

ACTION selection
for relay 2

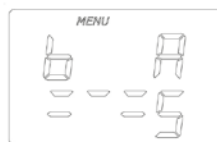

ACTION selection
for buzzer



Actions for Relay & Buzzer



Action 0, valid for relays and buzzer,
relay contact is always OPEN
buzzer is always SILENCE



Action 1, valid for relays and buzzer,
relay contact is CLOSED between points, OPEN under LOWpoint and OPEN over HIGHpoint
buzzer is WARNING between points, SILENCE under LOWpoint and SILENCE over HIGHpoint



Action 2, valid for relays and buzzer,
relay contact is OPEN between points, CLOSED under LOWpoint and OPEN over HIGHpoint
buzzer is SILENCE between points, WARNING under LOWpoint and SILENCE over HIGHpoint



Action 3, valid for relays and buzzer,
relay contact is CLOSED over HIGHpoint, OPEN under LOWpoint, hysteresis between points
buzzer is WARNING over HIGHpoint, SILENCE under LOWpoint, hysteresis between points



Action 4, valid for relays and buzzer,
relay contact is OPEN over HIGHpoint, CLOSED under LOWpoint, hysteresis between points
buzzer is SILENCE over HIGHpoint, WARNING under LOWpoint, hysteresis between points



Action 5, valid only for buzzer,
buzzer is WARNING over HIGHpoint, SILENCE under LOWpoint,
buzzer is WARNING intermittently between points,



Action 6, valid only for buzzer,
buzzer is WARNING under LOWpoint, SILENCE over HIGHpoint,
buzzer is WARNING intermittently between points,



Action 7, valid only for buzzer,
buzzer is following relay 1 contact,
buzzer is WARNING when relay 1 contact is CLOSED, SILENCE when the contact is OPEN



Action 8, valid only for buzzer,
buzzer is following relay 2 contact,
buzzer is WARNING when relay 2 contact is CLOSED, SILENCE when the contact is OPEN

AZIONI	sotto LOW	fra LOW e HIGH	sopra HIGH
0 : 0.0.0	Open / Silence	Open / Silence	Open / Silence
1 : 0.I.0	Open / Silence	Closed / Warning	Open / Silence
2 : I.0.I	Closed / Warning	Open / Silence	Closed / Warning
3 : 0.X.I	Open / Silence	Hysteresis	Closed / Warning
4 : I.X.0	Closed / Warning	Hysteresis	Open / Silence
5 : 0.-.I	Silence	Pre Alarm	Warning
6 : I.-.0	Warning	Pre Alarm	Silence
7 : = r1	Silence when RL1 is Open, Warning when RL1 is Closed		
8 : = r2	Silence when RL2 is Open, Warning when RL2 is Closed		

0 : Relay Contact is OPEN, Buzzer is in Silent mode

I : Relay Contact is CLOSED, Buzzer is in Warning mode

X : Relay Contact is at HYSTERESIS position, OPEN if previous position open, CLOSED if previous position closed

: Buzzer is in HYSTERESIS mode, Silent if previous mode is silent, Warning if previous mode is warning

- : Buzzer is in PRE ALARM mode, Buzzer is warning intermittently



Modbus RS485 protocol

Default Settings: Modbus ID:1, 9600, 8bit, None, 1. Register Table starts from Base 1.

Use Function 3 for Reading and Function 6 for Writing Holding Registers. Whenever writing to any Modbus Parameter, a new parameter is activated instantly and you should have to configure the master device according to the new parameters. For every reboot/initializing, Modbus is activated with default parameters for 3 seconds. After 3 seconds, Modbus is reconfigured according to your parameter settings. Unlisted registers are for analog output calibrations and some system parameters. Please do not change unlisted registers.

ID 254 is the general address. The transmitter replies to address 254 regardless of its own ID. Please use one master and one slave for checking the Modbus address. Also, baudrate and other parameters should match.

Register	R/W	Range	Description
1	R & W	1...254	Modbus Address
2	R & W	0...4	Baudrate, 0: 9.600, 1: 19.200
3	R & W	0...3	Bit_Parity_Stop, 0: 8bit_None_1, 1: 8bit_None_2, 2: 8bit_Even_1, 3: 8bit_Odd_1
4	R	0...500	VOC Index
5	R	0...65.536	VOC Raw Signal
6	R	0 or 1	Relay 1, contact position, 0: OFF - Contact is Open, 1: ON - Contact is Closed
7	R	0...1.000	Relay 1, LOW point
8	R	0...1.000	Relay 1, HIGH point
9	R	0...4	Relay 1, ACTION
10	R	0 or 1	Relay 2, contact position, 0: OFF - Contact is Open, 1: ON - Contact is Closed
11	R	0...1.000	Relay 2, LOW point
12	R	0...1.000	Relay 2, HIGH point
13	R	0...4	Relay 2, ACTION
14	R	0 or 1	Buzzer, 0: OK-Silence, 1: PreAlarm - warning intermittently, 2: WARNING continuously
15	R	0...1.000	Buzzer, LOW point
16	R	0...1.000	Buzzer, HIGH point
17	R	0...4	Buzzer, ACTION

Indoor Air Quality Index & PM2.5

The value 100 refers to the average indoor gas composition over the past 24 h. While values between 100 and 500 indicate a deterioration, values between up to 100 inform about improvement of the air quality. The Gas Index Algorithm is updated every second.

Dimensioni (mm)

without relay

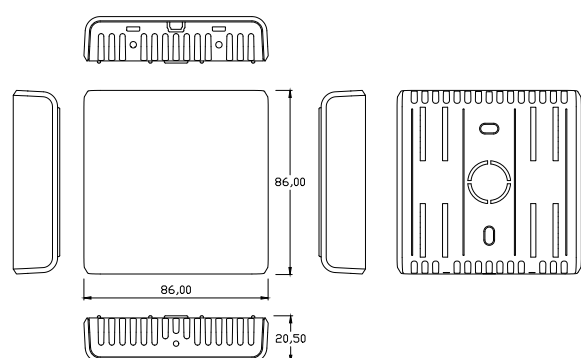

with relay

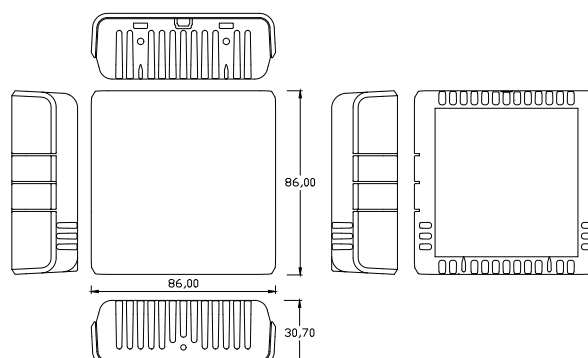





Description

The temperature transmitter serie TTI measures the room temperature by a sensor and converts the value into a linear output signal 0...10 VDC o 4...20 mA.

Technical specifications

Measurement range	See configurator
Accuracy	±0,2°C + max 3% FS
Sensor	PT1000 Class B (2-wire)
Power supply	12...34 VAC/DC
Working resistance at 0...10 V DC	10...100 kOhm
Working resistance at 4...20 mA	50...500 Ohm
Current consumption	24...44 mA
Electrical connection	Screw terminals max. 1,5 mm ²
Display	Optional, display the actual temperature
Dimensions	See drawing
Housing	ABS, RAL 9010
Protection type	IP20
Protection class	III
Installation	Screw fastening
Standards	CE conformity, RoHS



Model	Output	Version
TTIC	4...20 mA	
TTICD	4...20 mA	with display
TTIV	0...10 V DC	
TTIVD	0...10 V DC	with display

Electrical wirings

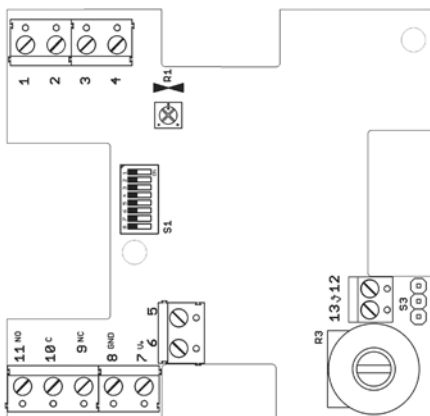

Output 0...10 V		Output 4...20 mA	
PIN	Assignment	PIN	Assignment
1	Temp.	1	-
2	-	2	-
3	-	3	Temp.
4	-	4	-
7	+	7	+
8	GND	8	GND



Settings

Temperature range selection	Range	1	2	3	4	5	6	7	8	Temperature range selection	Range	1	2	3	4	5	6	7	8		
	-100...+50°C	OFF	OFF	OFF	OFF	OFF	-	-	-		-10...+120°C	OFF	OFF	ON	ON	OFF	-	-	-	-	-
	-50...0°C	ON	OFF	OFF	OFF	OFF	-	-	-		0...+40°C	ON	OFF	ON	ON	OFF	-	-	-	-	-
	-50...50°C	OFF	ON	OFF	OFF	OFF	-	-	-		0...+50°C	OFF	ON	ON	ON	OFF	-	-	-	-	-
	-50...+150°C	ON	ON	OFF	OFF	OFF	-	-	-		0...+70°C	ON	ON	ON	ON	OFF	-	-	-	-	-
	-30...+20°C	OFF	OFF	ON	OFF	OFF	-	-	-		0...+100°C	OFF	OFF	OFF	OFF	ON	-	-	-	-	-
	-30...+60°C	ON	OFF	ON	OFF	OFF	-	-	-		0...+150°C	ON	OFF	OFF	OFF	ON	-	-	-	-	-
	-30...+70°C	OFF	ON	ON	OFF	OFF	-	-	-		0...+160°C	OFF	ON	OFF	OFF	ON	-	-	-	-	-
	-20...+50°C	ON	ON	ON	OFF	OFF	-	-	-		0...+200°C	ON	ON	OFF	OFF	ON	-	-	-	-	-
	-20...+80°C	OFF	OFF	OFF	ON	OFF	-	-	-		0...+250°C	OFF	OFF	ON	OFF	ON	-	-	-	-	-
	-20...+120°C	ON	OFF	OFF	ON	OFF	-	-	-		0...+400°C	ON	OFF	ON	OFF	ON	-	-	-	-	-
	-20...+150°C	OFF	ON	OFF	ON	OFF	-	-	-		0...+600°C	OFF	ON	ON	OFF	ON	-	-	-	-	-
-10...+15°C	ON	ON	OFF	ON	OFF	-	-	-	+10...+35°C	ON	ON	ON	OFF	ON	-	-	-	-	-		

Dimensions (mm)

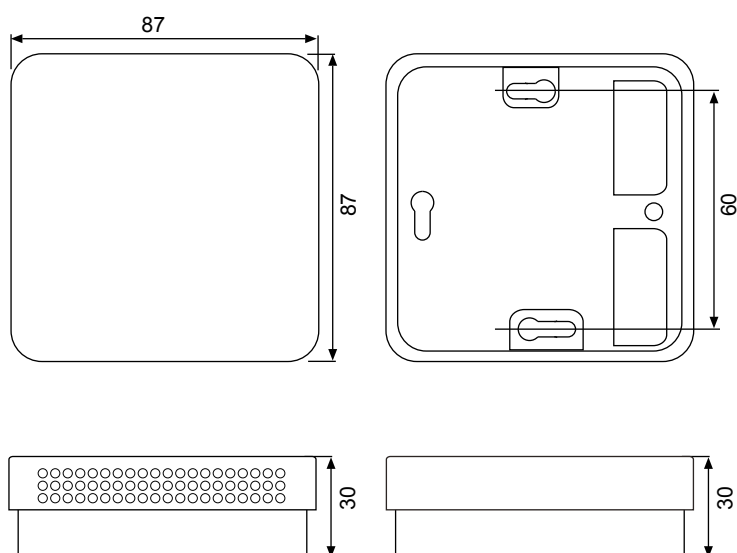



Description

The temperature transmitter serie TTO measures the outdoor temperature by sensor and converts the value into a linear output signal 0...10 VDC o 4...20 mA.

Technical specifications

Measurement range °C	See configurator
Accuracy °C	±0,2°C + max 3% of FS
Power supply	12...34 VAC/DC
Working resistance at 0...10 V DC	10...100 kOhm
Working resistance at 4...20 mA	50...500 Ohm
Consumption	24...44 mA
Electrical connection	Screw terminals max. 1,5 mm ²
Housing	PA6 15% GF, RAL9010
Dimensions	See drawing
Protection type	IP65
Protection class	III
Working range RH	0...98% RH in contaminant-free, non-condensing air
Working temperature °C	-30...+70°C
Standards	CE conformity, RoHS



Models	Temp. output	Version
TTOC*	4...20 mA	
TTOCD	4...20 mA	with display
TTOV	0...10 V DC	
TTOVD	0...10 V DC	with display

* available 2-wire version

Electrical wirings

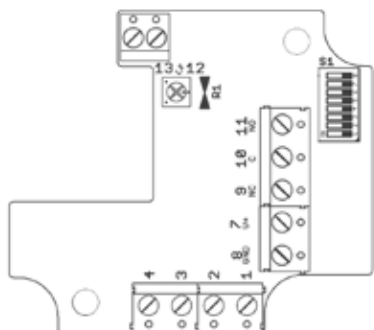

Output 0...10 V		Output 4...20 mA	
PIN	Assignment	PIN	Assignment
1	Temp.	1	-
2	-	2	-
3	-	3	Temp.
4	-	4	-
7	+	7	+
8	GND	8	GND

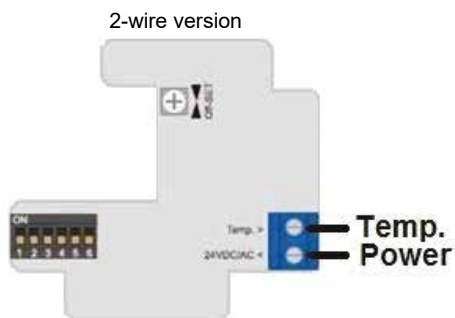

Important: connections in parallel with 24 VAC to consider the phase to prevent short circuits. The device is designed to operate in a low voltage condition.

Setting

	Range	1	2	3	4	5	6	7	8		Range	1	2	3	4	5	6	7	8
	Temperature range selection	-100...+50°C	OFF	OFF	OFF	OFF	OFF	-	-		-	Temperature range selection	-10...+120°C	OFF	OFF	ON	ON	OFF	-
	-50...0°C	ON	OFF	OFF	OFF	OFF	-	-	-		0...+40°C	ON	OFF	ON	ON	OFF	-	-	-
	-50...+50°C	OFF	ON	OFF	OFF	OFF	-	-	-		0...+50°C	OFF	ON	ON	ON	OFF	-	-	-
	-50...+150°C	ON	ON	OFF	OFF	OFF	-	-	-		0...+70°C	ON	ON	ON	ON	OFF	-	-	-
	-30...+20°C	OFF	OFF	ON	OFF	OFF	-	-	-		0...+100°C	OFF	OFF	OFF	OFF	ON	-	-	-
	-30...+60°C	ON	OFF	ON	OFF	OFF	-	-	-		0...+150°C	ON	OFF	OFF	OFF	ON	-	-	-
	-30...+70°C	OFF	ON	ON	OFF	OFF	-	-	-		0...+160°C	OFF	ON	OFF	OFF	ON	-	-	-
	-20...+50°C	ON	ON	ON	OFF	OFF	-	-	-		0...+200°C	ON	ON	OFF	OFF	ON	-	-	-
	-20...+80°C	OFF	OFF	OFF	ON	OFF	-	-	-		0...+250°C	OFF	OFF	ON	OFF	ON	-	-	-
	-20...+120°C	ON	OFF	OFF	ON	OFF	-	-	-		0...+400°C	ON	OFF	ON	OFF	ON	-	-	-
	-20...+150°C	OFF	ON	OFF	ON	OFF	-	-	-		0...+600°C	OFF	ON	ON	OFF	ON	-	-	-
	-10...+15°C	ON	ON	OFF	ON	OFF	-	-	-		+10...+35°C	ON	ON	ON	OFF	ON	-	-	-

Dimensions (mm)

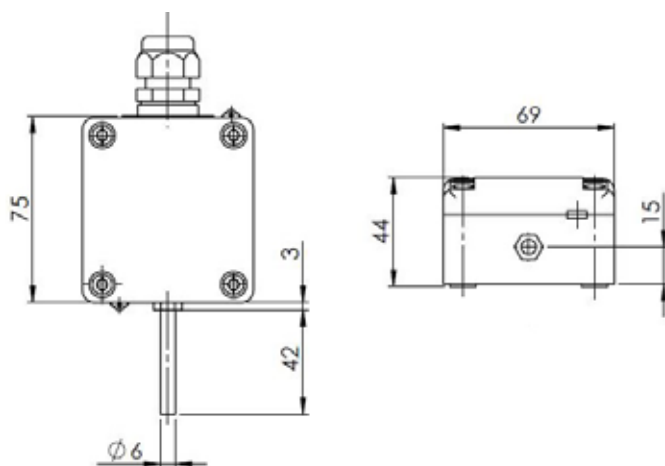



Description

The temperature transmitter serie TTOM measures the outdoor temperature by sensor and converts the value into a Modbus output signal.

Technical specifications

Accuracy °C	$\pm 0,2^{\circ}\text{K} \pm 1\%$ of FS
Power supply	12...34 V AC/DC
Consumption	10...20 mA
Electrical connection	Screw terminals max. 1,5 mm ²
Housing	PA6 15% GF, RAL9010
Dimensions	See drawing
Protection type	IP65
Working range RH	0...98% RH in contaminant-free, non-condensing air
Working temperature °C	-30...+70°C
Standards	CE conformity, RoHS



Electrical wirings

PIN	Wiring
1	SHD
2	B
3	A
4	+
5	GND

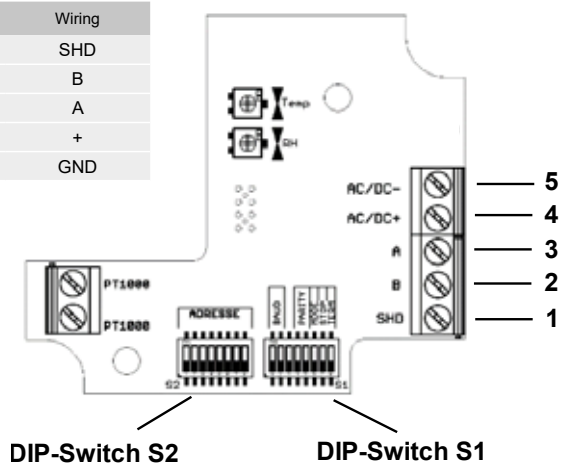

Measurement source

Unit	ModBus source	Gain
Temperature °C	50	10

DIP Switch 1	Setting	1	2	3	4	5	6	7	8	
	Baudrate									
	9600	OFF	OFF							
	19200	OFF	ON							
	38400	ON	OFF							
	57600	ON	ON							
	Termination									
	nessuna									OFF
	120 Ω									ON
	Parity									
Even				OFF	OFF					
Odd				OFF	ON					
No parità				ON	OFF					
No parità				ON	ON					
Modality										
RTU								OFF		
ASCII								ON		
Bit stop										
1									OFF	
2									ON	

Dimension (mm)

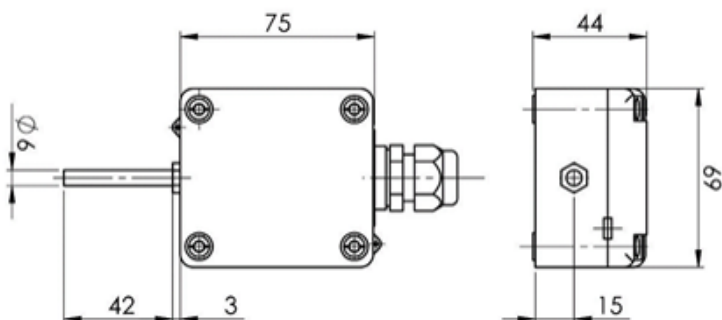



Description

The temperature transmitter serie TTD/TTS measures the duct or screw-in temperature by sensor and converts the value into a linear output signal 0...10 V DC o 4...20 mA.

Technical specifications

Measurement range °C	See configurator
Accuracy °C	±0,2°C + max 3% of FS
Power supply	12...34 V AC/DC
Working resistance at 0...10 V DC	10...100 kOhm
Working resistance at 4...20 mA	50...500 Ohm
Consumption	24...44 mA
Electrical connection	Screw terminals max. 1,5 mm ²
Housing	PA6 15% GF, RAL9010
Dimensions	See drawing
Protection type	IP65
Protection class	III
Working range RH	0...98% RH in contaminant-free, non-condensing air
Working temperature °C	-30...+70°C
Standards	CE conformity, RoHS



Models	Temp. output	Version	Display
TTDC	4...20 mA	Duct	
TTDCD	4...20 mA	Duct	with display
TTDV	0...10 V DC	Duct	
TTDVD	0...10 V DC	Duct	with display
TTSC	4...20 mA	Screw-in	
TTSCD	4...20 mA	Screw-in	with display
TTSV	0...10 V DC	Screw-in	
TTSVD	0...10 V DC	Screw-in	with display



Electrical wirings

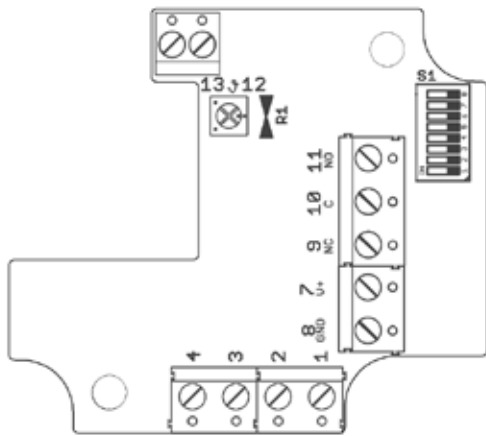

Output 0...10 V		Output 4...20 mA	
PIN	Assignment	PIN	Assignment
1	Temp.	1	-
2	-	2	-
3	-	3	Temp.
4	-	4	-
7	+	7	+
8	GND	8	GND

Important: connections in parallel with 24 VAC to consider the phase to prevent short circuits. The device is designed to operate in a low voltage condition.

Setting

	Range	1	2	3	4	5	6	7	8	
	Temperature range selection	-100...+50°C	OFF	OFF	OFF	OFF	OFF	-	-	-
-50...0°C		ON	OFF	OFF	OFF	OFF	-	-	-	
-50...50°C		OFF	ON	OFF	OFF	OFF	-	-	-	
-50...+150°C		ON	ON	OFF	OFF	OFF	-	-	-	
-30...+20°C		OFF	OFF	ON	OFF	OFF	-	-	-	
-30...+60°C		ON	OFF	ON	OFF	OFF	-	-	-	
-30...+70°C		OFF	ON	ON	OFF	OFF	-	-	-	
-20...+50°C		ON	ON	ON	OFF	OFF	-	-	-	
-20...+80°C		OFF	OFF	OFF	ON	OFF	-	-	-	
-20...+120°C		ON	OFF	OFF	ON	OFF	-	-	-	
-20...+150°C		OFF	ON	OFF	ON	OFF	-	-	-	
-10...+15°C		ON	ON	OFF	ON	OFF	-	-	-	
	Range	1	2	3	4	5	6	7	8	
	Temperature range selection	-10...+120°C	OFF	OFF	ON	ON	OFF	-	-	-
		0...+40°C	ON	OFF	ON	ON	OFF	-	-	-
		0...+50°C	OFF	ON	ON	ON	OFF	-	-	-
		0...+70°C	ON	ON	ON	ON	OFF	-	-	-
		0...+100°C	OFF	OFF	OFF	OFF	ON	-	-	-
		0...+150°C	ON	OFF	OFF	OFF	ON	-	-	-
		0...+160°C	OFF	ON	OFF	OFF	ON	-	-	-
		0...+200°C	ON	ON	OFF	OFF	ON	-	-	-
		0...+250°C	OFF	OFF	ON	OFF	ON	-	-	-
		0...+400°C	ON	OFF	ON	OFF	ON	-	-	-
		0...+600°C	OFF	ON	ON	OFF	ON	-	-	-
+10...+35°C		ON	ON	ON	OFF	ON	-	-	-	

Dimensions (mm)

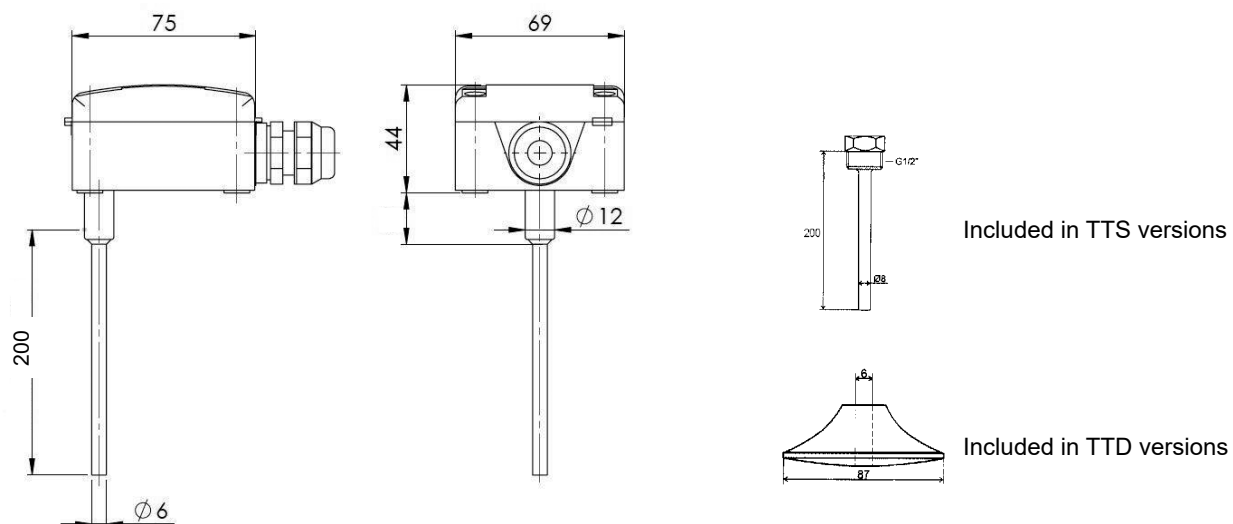

Description



The temperature transmitter serie TTDM/TTSM measures the duct or screw-in temperature by sensor and converts the value into a Modbus 485 signal.

Technical specifications

Accuracy °C	±0,2°C + max 3% of FS
Power supply	12...34 V AC/DC
Consumption	10...20 mA
Electrical connection	Screw terminals max. 1,5 mm ²
Housing	PA6 15% GF, RAL9010
Dimensions	See drawing
Protection type	IP65
Protection class	III
Working range RH	0...98% RH in contaminant-free, non-condensing air
Working temperature °C	-30...+70°C
Standards	CE conformity, RoHS



Models	Version
TTDM	Duct
TTSM	Screw-in

Electrical wirings

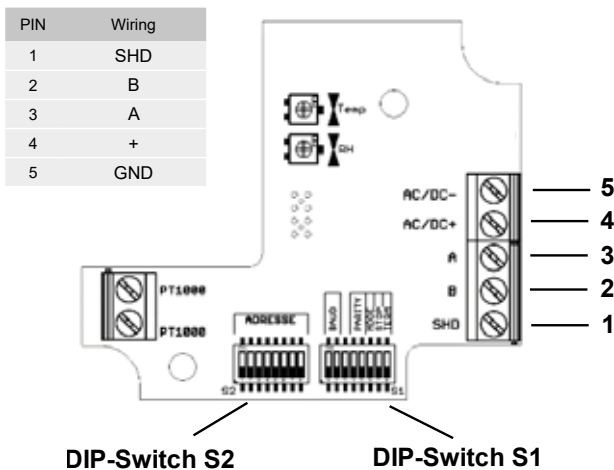

Measurement source

Unit	ModBus source	Gain
Temperature °C	20	10

DIP Switch 1	Setting	1	2	3	4	5	6	7	8	
	Baudrate									
	9600	OFF	OFF							
	19200	OFF	ON							
	38400	ON	OFF							
	57600	ON	ON							
	Termination									
	nessuna									OFF
	120 Ω									ON
	Parity									
Even				OFF	OFF					
Odd				OFF	ON					
No parità				ON	OFF					
No parità				ON	ON					
Modality										
RTU								OFF		
ASCII								ON		
Bit stop										
1									OFF	
2									ON	



Description

The temperature/humidity transmitter serie TTHI measures the room temperature and humidity by capacitive sensors and converts the value into a linear output signal 0...10 V DC or 4...20 mA.

Technical specifications

Measurement range RH	Selectable by dip-switch
Accuracy RH	±2% RH (20...80%RH) + 2% FS
Measurement range °C	4 different scale selectable by dip-switch
Accuracy °C	±0,3°C (5...60°C) + 1% FS
Power supply	12...34 V AC/DC
Power consumption	24...44 mA
Working resistance at 0...10 V	10...100 kOhm
Working resistance at 4...20 mA	50...500 Ohm
Speed of response RH	8 sec.
Electrical connection	Screw terminals max. 1,5 mm ²
Housing	ABS, RAL 9010
Dimensions	See drawing
Protection type	IP30
Protection class	III
Working range RH	0...98% RH in contaminant-free, non-condensing air
Working temperature °C	0...+50°C
Installation	Screw fastening
Standards	CE conformity, RoHS



Models	Temp. output	Humidity output	Version
TTHIV	0...10 V DC	0...10 V DC	
TTHIxV	Passive sensor (*)	0...10 V DC	
TTHIVD	0...10 V DC	0...10 V DC	with display
TTHIxVD	Passive sensor (*)	0...10 V DC	with display
TTHIC	4...20 mA	4...20 mA	
TTHIxC	Passive sensor (*)	4...20 mA	
TTHICD	4...20 mA	4...20 mA	with display
TTHIxCD	Passive sensor (*)	4...20 mA	con display

(*) Replace "x" with the number of desired passive sensor:

X	Type of passive sensor
1	Pt100 (DIN EN 60751 Cl. B)
2	Pt1000 (DIN EN 60751 Cl. B)
3	Ni1000 (TK6180)
5	NTC20k (±1%)
6	NTC10k (±1%) BETA 3435K



Electrical wirings

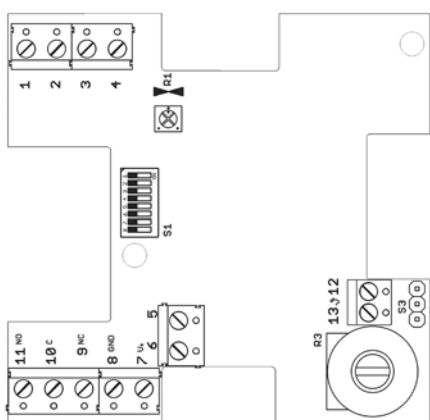

Output 0...10 V		Output 4...20 mA	
PIN	Assignment	PIN	Assignment
1	Output temp.	1	-
2	Output humid.	2	-
3	-	3	Output temp.
4	-	4	Output humid.
7	+	7	+
8	GND	8	GND
12	passive sensor	12	passive sensor
13	passive sensor	13	passive sensor

Important: connections in parallel with 24 VAC to consider the phase to prevent short circuits. The device is designed to operate in a low voltage condition.

Note: The sensor is designed for a normal environment condition, other aggressive gases can ruin it.

Setting

Temperature ranges	Range	1	2	Humidity ranges	Range	3	4	5	6	
	0...+50°C	OFF	OFF		Relative humidity	0...100%	OFF	OFF	OFF	OFF
	0...+100°C	ON	OFF		Absolute humidity	0 g/m ³ ...30g/m ³	ON	OFF	OFF	OFF
	-20...+80°C	OFF	ON		0 g/m ³ ...50g/m ³	ON	ON	OFF	OFF	
	-30...+70°C	ON	ON		0 g/m ³ ...80g/m ³	ON	ON	ON	OFF	
				Mix ratio	0 g/kg...30g/kg	OFF	OFF	OFF	ON	
				0 g/kg...50g/kg	OFF	OFF	ON	ON		
				0 g/kg...80g/kg	OFF	ON	ON	ON		
				Dew point	0...+50°C	OFF	ON	ON	OFF	
				-50...+100°C	ON	OFF	OFF	ON		
				-20...+80°C	OFF	ON	OFF	ON		
				Enthalpy	0 kJ/kg...85kJ/kg	ON	ON	ON	ON	

Dimensions (mm)

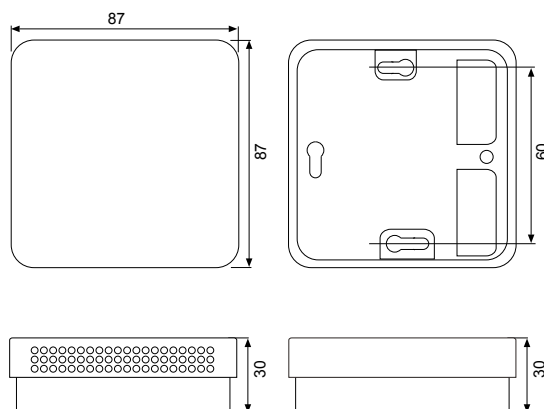



Description

The temperature/humidity transmitter serie TTHO measures the outdoor temperature and humidity by a capacitive humidity sensor and converts the value into a linear output signal 0...10 V DC o 4...20 mA. The humidity and temperature sensor is protected against contamination by a screw sinter filter.

Technical specifications

Measurement range RH	Selectable
Accuracy RH	±2% RH (20...80% RH) + 2% FS
Measurement range °C	4 different scale selectable by dip-switch
Accuracy °C	±0,3°C (5...60°C) + 1,5% FS
Power supply	12...34 V AC/DC
Power consumption	24...44 mA
Working resistance at 0...10 V DC	10...100 kOhm
Working resistance at 4...20 mA	50...500 Ohm
Electrical connection	Screw terminals max. 1,5 mm ²
Housing	PA6 15% GF, RAL9010
Dimensions	See drawing
Protection type	IP65
Protection class	III
Working range RH	0...98% RH in contaminant-free, non-condensing air
Working temperature °C	-30...+70°C
Standards	CE conformity, RoHS



Models	Temp. output	Humidity output	Version
TTHOC	4...20 mA	4...20 mA	
TTHOxC	Passive sensor (*)	4...20 mA	
TTHOCD	4...20 mA	4...20 mA	with display
TTHOxCD	Passive sensor (*)	4...20 mA	with display
TTHOV	0...10 V DC	0...10 V DC	
TTHOxV	Passive sensor (*)	0...10 V DC	
TTHOVD	0...10 V DC	0...10 V DC	with display
TTHOxVD	Passive sensor (*)	0...10 V DC	with display

(*) Replace "x" with the number of desired passive sensor:

X	Type of passive sensor
1	Pt100 (DIN EN 60751 Cl. B)
2	Pt1000 (DIN EN 60751 Cl. B)
3	Ni1000 (TK6180)
5	NTC20k (±1%)
6	NTC10k (±1%) BETA 3435K



Electrical wirings

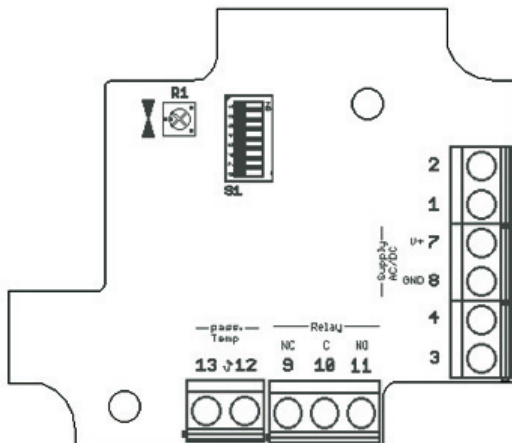

Output 0...10 V		Output 4...20 mA	
PIN	Assignment	PIN	Assignment
1	Output temp.	1	-
2	Output humid.	2	-
3	-	3	Output temp.
4	-	4	Output humid.
7	+	7	+
8	GND	8	GND
12	passive sensor	12	passive sensor
13	passive sensor	13	passive sensor

Important: connections in parallel with 24 VAC to consider the phase to prevent short circuits. The device is designed to operate in a low voltage condition.

Note: The sensor is designed for a normal environment condition, other aggressive gases can ruin it.

Setting

Temperature ranges	Range	1	2	Humidity ranges	Range	3	4	5	6	
	-30...+70°C	OFF	OFF		Relative humidity	0...100%	OFF	OFF	OFF	OFF
	-20...+80°C	ON	OFF		Absolute humidity	0 g/m ³ ...30g/m ³	ON	OFF	OFF	OFF
	0...+100°C	OFF	ON		0 g/m ³ ...50g/m ³	ON	ON	OFF	OFF	OFF
	0...+50°C	ON	ON		0 g/m ³ ...80g/m ³	ON	ON	ON	OFF	OFF
				Mix ratio	0 g/kg...30g/kg	OFF	OFF	OFF	ON	
				0 g/kg...50g/kg	OFF	OFF	ON	ON	ON	
				0 g/kg...80g/kg	OFF	ON	ON	ON	ON	
				Dew point	0...+50°C	OFF	ON	ON	OFF	
				-50...+100°C	ON	OFF	OFF	ON	ON	
				-20...+80°C	OFF	ON	OFF	ON	ON	
				Enthalpy	0 kJ/kg...85kJ/kg	ON	ON	ON	ON	

Dimensions (mm)

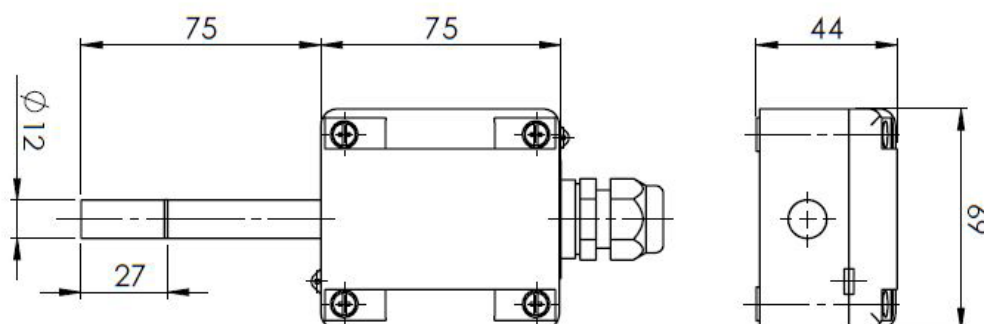



Description

The temperature/humidity transmitter serie TTHDM measures the outdoor temperature and humidity by a capacitive humidity sensor and converts the value into an RS485 output signal with ModBus RTU/ASCII protocol. The sensor is protected by a sintered filter.

Technical specifications

Measurement range RH	0...100% RH
Accuracy RH	±2% RH (20...80%RH) +2% FS a 25°C
Accuracy °C	±0,3°C (5...60°C) + 1,5% FS
Power supply	12...34 V AC/DC
Power consumption	10...20 mA
Electrical connection	Screw terminals max. 1,5 mm ²
Housing	PA6 15% GF, RAL 9010
Dimensions	See drawing
Protection type	IP65
Protection class	III
Working range RH	0...98% RH in contaminant-free, non-condensing air
Working temperature °C	-30...+70°C
Standards	CE conformity, RoHS



Models	Version
TTHOM	
TTHOMD	with display

Measurement source

Unit	ModBus source	Gain
Temperature °C	20	10
Relative humidity %u.r.	21	10
Absolute humidity g/m ³	22	10
Dewpoint °C	23	10
Enthalpy J	24	10

Electrical wirings

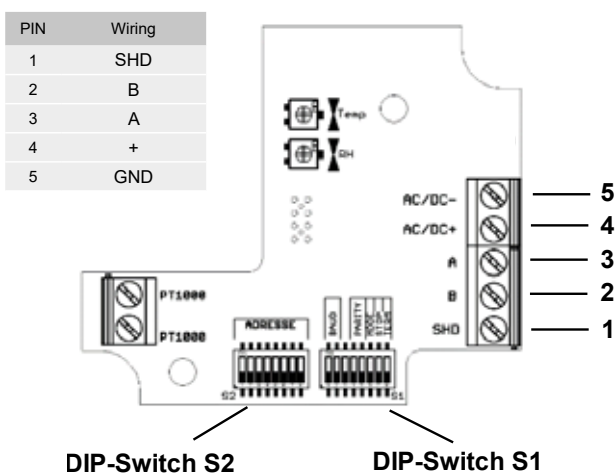

DIP Switch 1	Setting	1	2	3	4	5	6	7	8
	Baudrate								
	9600	OFF	OFF						
	19200	OFF	ON						
	38400	ON	OFF						
	57600	ON	ON						
Termination									
	nessuna								OFF
	120 Ω								ON
Parity									
	Even				OFF	OFF			
	Odd				OFF	ON			
	No parità				ON	OFF			
	No parità				ON	ON			
Modality									
	RTU							OFF	
	ASCII							ON	
Bit stop									
	1								OFF
	2								ON



Description

The temperature/humidity transmitter serie TTHD measures the duct temperature and humidity by a capacitive sensor and converts the value into a linear output signal 0...10 V DC or 4...20 mA.

Technical specifications

Measurement range RH	Selectable by dip-switch
Accuracy RH	±2% RH (20...80%RH) + 2% FS
Measurement range °C	4 different scale selectable by dip-switch
Accuracy °C	±0,3°C (5...60°C)
Speed of response	8 sec.
Power supply	12...34 V AC/DC
Power consumption	24...44 mA
Working resistance at 0...10 V DC	10...100 kOhm
Working resistance at 4...20 mA	50...500 Ohm
Electrical connection	Screw terminals max. 1,5 mm ²
Housing	PA6 15% GF, RAL 9010
Dimensions	See drawing
Protection type	IP65
Protection class	II
Working range RH	0...98% RH in contaminant-free, non-condensing air
Working temperature °C	-30...+70°C
Installation	Mounting flange (included)
Standards	CE conformity, RoHS



Models	Temp. output	Humidity output	Version
TTHDV	0...10 V DC	0...10 V DC	
TTHDVD	0...10 V DC	0...10 V DC	with display
TTHDxV	Passive sensor (*)	0...10 V DC	
TTHDxVD	Passive sensor (*)	0...10 V DC	with display
TTHDC	4...20 mA	4...20 mA	
TTHDCD	4...20 mA	4...20 mA	with display
TTHDxC	Passive sensor (*)	4...20 mA	
TTHDxCD	Passive sensor (*)	4...20 mA	with display

(*) Replace "x" with the number of desired passive sensor:

X	Type of passive sensor
1	Pt100 (DIN EN 60751 Cl. B)
2	Pt1000 (DIN EN 60751 Cl. B)
3	Ni1000 (TK6180)
5	NTC20k (±1%)
6	NTC10k (±1%) BETA 3435K



Electrical wirings

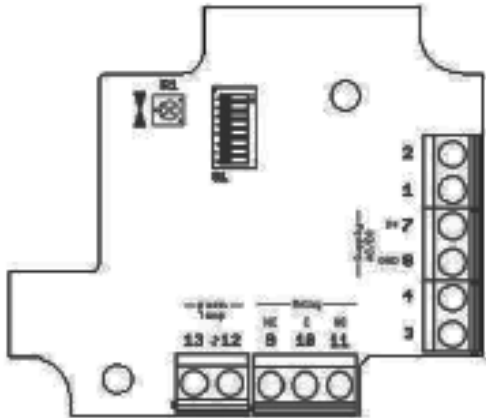

Output 0...10 V		Output 4...20 mA	
PIN	Assignment	PIN	Assignment
1	Output temp.	1	-
2	Output humid.	2	-
3	-	3	Output temp.
4	-	4	Output humid.
7	+	7	+
8	GND	8	GND
12	passive sensor	12	passive sensor
13	passive sensor	13	passive sensor

Important: connections in parallel with 24 VAC to consider the phase to prevent short circuits. The device is designed to operate in a low voltage condition.

Note: The sensor is designed for a normal environment condition, other aggressive gases can ruin it.

Setting

Temperature ranges	Range	1	2	Humidity ranges	Range	3	4	5	6	
	-30...+70°C	OFF	OFF		Relative humidity	0...100%	OFF	OFF	OFF	OFF
	-20...+80°C	ON	OFF		Absolute humidity	0 g/m ³ ...30g/m ³	ON	OFF	OFF	OFF
	0...+100°C	OFF	ON		0 g/m ³ ...50g/m ³	ON	ON	OFF	OFF	
	0...+50°C	ON	ON		0 g/m ³ ...80g/m ³	ON	ON	ON	OFF	
				Mix ratio	0 g/kg...30g/kg	OFF	OFF	OFF	ON	
				0 g/kg...50g/kg	OFF	OFF	ON	ON		
				0 g/kg...80g/kg	OFF	ON	ON	ON		
				Dew point	0...+50°C	OFF	ON	ON	OFF	
				-50...+100°C	ON	OFF	OFF	ON		
				-20...+80°C	OFF	ON	OFF	ON		
				Enthalpy	0 kj/kg...85kj/kg	ON	ON	ON	ON	

Dimensions (mm)

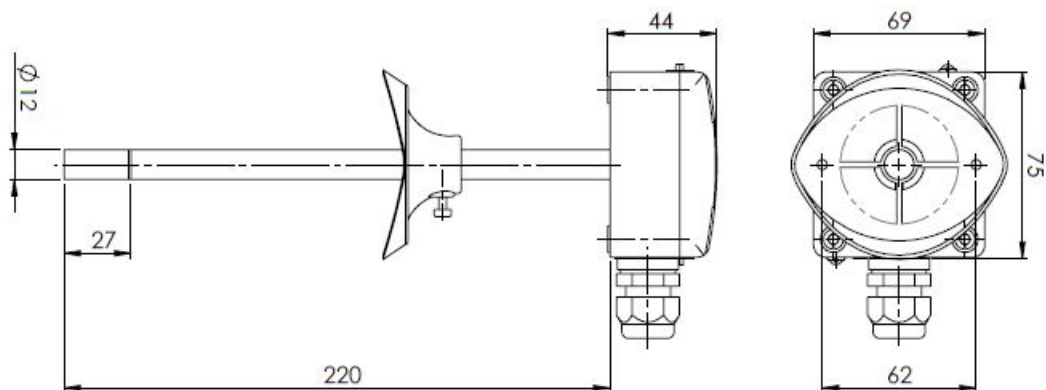



Description

The temperature/humidity transmitter serie TTHDM measures the duct temperature and humidity by a capacitive humidity sensor and converts the value into an RS485 output signal with ModBus RTU/ASCII protocol. The sensor is protected by a sintered filter.

Technical specifications

Measurement range RH	0...100% RH
Accuracy RH	±2% RH (20...80%RH) +2% FS a 25°C
Accuracy °C	±0,3°C (5...60°C) + 1,5% FS
Power supply	12...34 V AC/DC
Power consumption	10...20 mA
Electrical connection	Screw terminals max. 1,5 mm ²
Housing	PA6, RAL 9010
Dimensions	See drawing
Protection type	IP65
Protection class	III
Working range RH	0...98% RH in contaminant-free, non-condensing air
Working temperature °C	-30...+70°C
Installation	Mounting flange (included)
Standards	CE conformity, RoHS



Models	Version
TTHDM	
TTHDMD	with display

Measurement source

Unit	ModBus source	Gain
Temperature °C	20	10
Relative humidity %u.r.	21	10
Absolute humidity g/m ³	22	10
Dewpoint °C	23	10
Enthalpy J	24	10

Electrical wirings

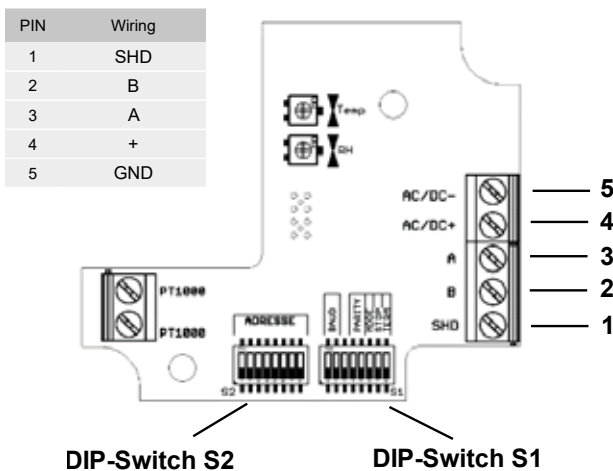

DIP Switch 1	Setting	1	2	3	4	5	6	7	8	
	Baudrate									
	9600	OFF	OFF							
	19200	OFF	ON							
	38400	ON	OFF							
	57600	ON	ON							
	Termination									
	nessuna									OFF
	120 Ω									ON
	Parity									
Even				OFF	OFF					
Odd				OFF	ON					
No parità				ON	OFF					
No parità				ON	ON					
Modality										
RTU								OFF		
ASCII								ON		
Bit stop										
1									OFF	
2									ON	



Description

The SAC CO₂ sensor measures air quality through the presence of carbon dioxide in the room in the range between 0...2000 or 0...5000 ppm. The measurement of CO₂ concentration happens through a NDIR sensor that operates on an infrared basis and which compensates the presence of any impurity. The product can be provided with humidity or humidity/temperature sensor. Output 0 ... 10 V DC or 4 ... 20 mA outputs.

Technical specifications

Measurement range CO₂	0...2000 / 0...5000 ppm
Accuracy CO₂	±60 ppm (0...2000 ppm) ±2% FS ±150 ppm (0...5000 ppm) ±2% FS
Accuracy temperature	± 0,3K (5...60°C) + 1% FS
Accuracy humidity	25°C ± 2% RH (20...80%RH) + 2% FS
Power supply	12...34 V AC/DC (20...34 V AC/DC with relay)
Power consumption	40...100 mA
Sensor setting up time	60 min.
Working resistance at 0...10 V DC	10...100 kOhm
Working resistance at 4...20 mA	50...500 Ohm
CO₂ sensitive element	NDIR self adjusting
Sensible element	Self-calibrating NDIR
Electrical connection	Screw terminal for cables 1,5 mm ²
Protection type	IP 30
Housing	ABS RAL9010
Working range RH	0...98% RH in contaminant-free, non-condensing air
Working temperature °C	0...+50°C
Standards	CE, RoHs compliance



Model	Temperature	Humidity	Output
SACV	-	-	0...10 V DC
SACTV	•	-	0...10 V DC
SACTHV	•	•	0...10 V DC
SACC	-	-	4...20 mA
SACTC	•	-	4...20 mA
SACHC	-	•	4...20 mA

Optional: suffix "D" version with display and/or suffix "R" relay version

(*) Replace "X" with the number of selected passive sensor:

"X"	Type of passive sensor
1	Pt100 (DIN EN 60751 Cl. B)
3	Ni1000 (TK6180)
5	NTC20k (±1%)
6	NTC10k (±1%) BETA 3435K

Electrical wirings

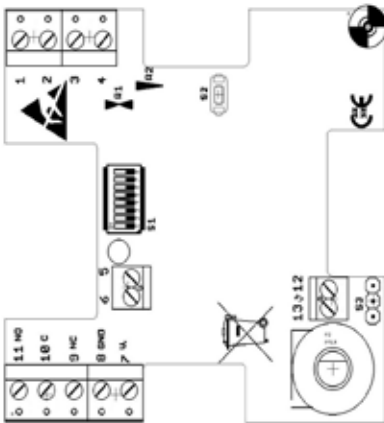

Output 0...10 V				Output 4...20 mA			
PIN	CO ₂	CO ₂ /T	CO ₂ /T/H	PIN	CO ₂	CO ₂ /T	CO ₂ /H
1	ppm	temp	temp	1	-	-	-
2	-	ppm	humidity	2	-	-	-
3	-	-	ppm	3	ppm	temp	humidity
4	-	-	-	4		ppm	ppm
5	(passive poti)						
6	(passive poti)						
7	V+						
8	GND						
9	(relay NC)						
10	(relay C)						
11	(relay NO)						
12	(passive sensor)						
13	(passive sensor)						
S3	polarity R3						
S2	CO ₂ Manual adjustment to 400 ppm						

Dip-switch setting

Temperature range selection	Range	1	2	Humidity range selection	Range	3	4	5	6	CO ₂ range selection / setting	Range	7	8		
	-30...+70°C	OFF	OFF		Relative humidity	0...100%	OFF	OFF	OFF		OFF	CO ₂	0...2000 ppm	OFF	
	-20...+80°C	ON	OFF		Absolute humidity	0 g/m ³ ...30g/m ³	ON	OFF	OFF		OFF	0...5000 ppm	ON		
	0...+50°C	ON	ON		0 g/m ³ ...50g/m ³	ON	ON	OFF	OFF			Self adjusting	Not activated	ON	
	0...+100°C	OFF	ON		0 g/m ³ ...80g/m ³	ON	ON	ON	OFF			Activated	OFF		
				Mix ratio	0 g/kg...30g/kg	OFF	OFF	OFF	ON						
				0 g/kg...50g/kg	OFF	OFF	ON	ON							
				0 g/kg...80g/kg	OFF	ON	ON	ON							
				Dew point	0...+50°C	OFF	ON	ON	OFF						
				-50...+100°C	ON	OFF	OFF	ON							
				-20...+80°C	OFF	ON	OFF	ON							
				Enthalpy	0 kJ/kg...85kJ/kg	ON	ON	ON	ON						

Autocalibration CO₂ sensor: The sensor must be mounted with the ventilation slots against the flow direction. The screw connector shall be installed in the direction of the ventilation slots. The sensor shall be exposed to fresh air at least once a day, otherwise it will give incorrect readings on long term. The sensor requires 15 days of calibration to be adapted to the real values.

Dimension (mm)

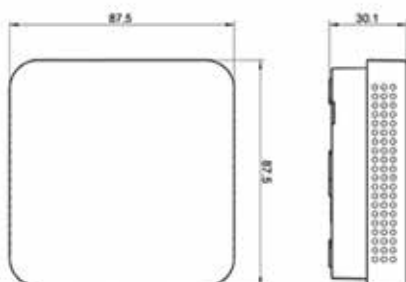



Description

The SAC CO₂ sensor measures air quality through the presence of carbon dioxide in the room in the range between 0...2000 or 0...5000 ppm. The measurement of CO₂ concentration happens through a NDIR sensor that operates on an infrared basis and which compensates the presence of any impurity. The product can be provided with humidity or humidity/temperature sensor.

Technical specifications

Measurement range CO₂	0...2000 / 0...5000 ppm
Accuracy CO₂	±60 ppm (0...2000 ppm) ±2% FS ±150 ppm (0...5000 ppm) ±2% FS
Accuracy temperature	± 0,3K (5...60°C) + 1% FS
Accuracy humidity	25°C ± 2% RH (20...80%RH) + 2% FS
Power supply	12...34 V AC/DC (20...34 V AC/DC)
Power consumption	40...100 mA
Sensor setting up time	60 min.
CO₂ sensitive element	NDIR self adjusting
Electrical connection	Screw terminal for cables 1,5 mm ²
Protection type	IP 30
Weight	ca. 70 g
Housing	ABS RAL9010
Working range RH	0...98% RH in contaminant-free, non-condensing air
Working temperature °C	0...+50°C
Standards	CE, RoHs compliance



Measurement source

Model	Temperature	Humidity
SACM	-	-
SACTM	•	-
SACTHM	•	•

Unit	ModBus source	Gain
ppm CO ₂	10	-
Temperature °C	20	-
Relative humidity %u.r.	21	-
Absolute humidity g/m ³	22	-
Dewpoint °C	23	-
Enthalpy J	24	-

Electrical wirings

PIN	Wiring
1	SHD
2	B
3	A
4	+
5	GND

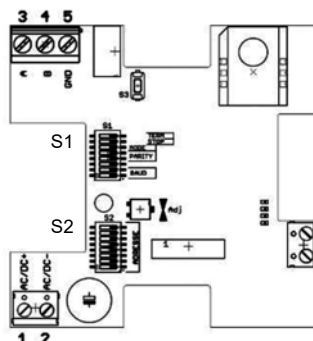



Dip-switch setting

Setting	1	2	3	4	5	6	7	8
Baudrate								
9600	OFF	OFF						
19200	OFF	ON						
38400	ON	OFF						
57600	ON	ON						
Termination								
nessuna								OFF
120 Ω								ON
Parity								
Even				OFF	OFF			
Odd				OFF	ON			
No parità				ON	OFF			
No parità				ON	ON			
Modality								
RTU						OFF		
ASCII						ON		
Bit stop								
1							OFF	
2							ON	

Autocalibration CO₂ sensor: The sensor must be mounted with the ventilation slots against the flow direction. The screw connector shall be installed in the direction of the ventilation slots.
 The sensor shall be exposed to fresh air at least once a day, otherwise it will give incorrect readings on long term.
 The sensor requires 15 days of calibration to be adapted to the real values.

Dimension (mm)

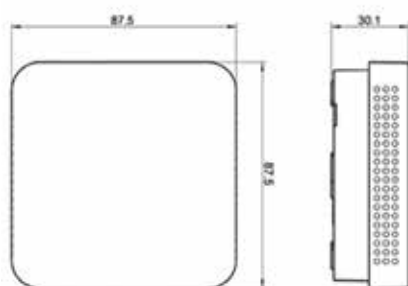



Description

The air quality sensor serie SAV for mixed gases (VOC) measures the air quality from 0...2000 ppm referring to the calibration gas. The sensors with provided by linear output signal 0...10 V DC or 4...20 mA. Optional a relay SPTD.

Technical specifications

Measurement range VOC	0...2000 ppm
Tolerance	±2% FS
Measurement range °C (optional)	see configuration
Accuracy °C	±0,3°C (5...60°C) + 2,5% FS
Measurement range RH (optional)	0...100% RH
Accuracy RH	±2% RH (20...80%RH) + 2% FS
Power supply	12...34 V AC/DC (20...34 V AC/DC with relay)
Calibration (corresponds)	Good air approx 1 Vdc ... 4 mA = 250 ppm CO ₂ equivalent 5 Vdc ... 12 mA = 1175 ppm CO ₂ equivalent 10 Vdc ... 20 mA = 2000 ppm CO ₂ equivalent
Power consumption	40...100 mA
Sensor setting up time	60 min
Working resistance at 0...10 V DC	10...100 kOhm
Working resistance at 4...20 mA	50...500 Ohm
Relay	SPTD potential free. Changing at 800 ppm
Relay contact	Max 24 V, 1 A
Electrical connection	Screw terminal for cables 1,5 mm ²
Housing	ABS (plastic) colour white RAL9010
Weight	approx. 70 g
Protection type	IP30
Working range RH	0...98% RH in contaminant-free, non-condensing air
Working temperature	0...+50°C
Standards	CE conformity, RoHS



Models	Temperature	Humidity	Output
SAVV	-	-	0...10 V DC
SAVTV	•	-	0...10 V DC
SAVTHV	•	•	0...10 V DC
SAVC	-	-	4...20 mA
SAVTC	•	-	4...20 mA
SAVHC	-	•	4...20 mA

Optional: suffix "R" relay version

Electrical wirings

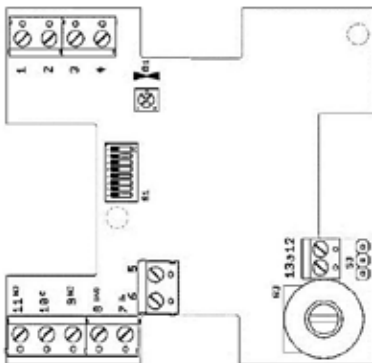

Output 0...10 Vdc				Output 4...20 mA			
PIN	VOC	VOC/T	VOC/T/H	PIN	VOC	VOC/T	VOC/H
1	VOC	temp	temp	1	-	-	-
2	-	VOC	humidity	2	-	-	-
3	-	-	VOC	3	VOC	temp	humidity
4	-	-	-	4	-	VOC	VOC
7	+						
8	GND						
9	Relay NC						
10	Relay COM						
11	Relay NO						
12	(passive sensor)						
13	(passive sensor)						
S3	polarity R3						



Dip-switch setting

Temperature range selection			Humidity range selection							
Range	1	2	Range	3	4	5	6	7	8	
0...+50°C	OFF	OFF	Relative humidity							
0...+100°C	ON	OFF	0...100%	OFF	OFF	OFF	OFF	-	-	
-20...+80°C	OFF	ON	Absolute humidity							
-30...+70°C	ON	ON	0 g/m ³ ...30g/m ³	ON	OFF	OFF	OFF	-	-	
			0 g/m ³ ...50g/m ³	ON	ON	OFF	OFF	-	-	
			0 g/m ³ ...80g/m ³	ON	ON	ON	OFF	-	-	
			Mix ratio							
			0 g/kg...30g/kg	OFF	OFF	OFF	ON	-	-	
			0 g/kg...50g/kg	OFF	OFF	ON	ON	-	-	
			0 g/kg...80g/kg	OFF	ON	ON	ON	-	-	
			Dew point							
			0...+50°C	OFF	ON	ON	OFF	-	-	
			-50...+100°C	ON	OFF	OFF	ON	-	-	
			-20...+80°C	OFF	ON	OFF	ON	-	-	
			Enthalpy							
			0 kJ/kg...85kJ/kg	ON	ON	ON	ON	-	-	

WARNING: At the sensor is needed warming up at powering, therefore it takes about 60 minutes before having a signal. In this phase, the sensor must be placed in the fresh air to take it as a reference. If you remove the power supply voltage it is necessary to wait 60 minutes. Generally the sensor should be placed into fresh air at least once a day. This procedure prevents a long-term drift.

Measuring behaviour

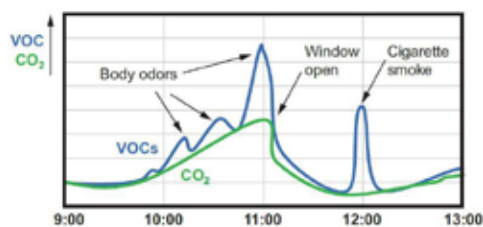

Dimensions (mm)

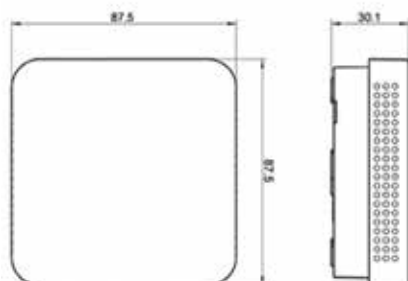



Description

The SACV CO₂ and VOC sensor measures the presence of carbon dioxide and mixed gases in the room in the range between 0...2000 or 0...5000 ppm. The measurement of CO₂ concentration happens through a NDIR sensor that operates on an infrared basis and which compensates the presence of any impurity. The product can be provided with humidity or humidity/temperature sensor. Output 0 ... 10 V DC or 4 ... 20 mA outputs.

Technical specifications

Measurement range	0...2000 / 0...5000 ppm
Accuracy CO₂	±60 ppm (0...2000 ppm) ±2% FS ±150 ppm (0...5000 ppm) ±2% FS
Accuracy temperature	± 0,3K (5...60°C) + 1% FS
Accuracy humidity	25°C ± 2% RH (20...80%RH) + 2% FS
Power supply	12...34 V AC/DC (20...34 V AC/DC with relay)
Power consumption	40...100 mA
Sensor setting up time	60 min.
Working resistance at 0...10 V DC	10...100 kOhm
Working resistance at 4...20 mA	50...500 Ohm
CO2 sensitive element	NDIR self adjusting
Sensible element	Self-calibrating NDIR
Electrical connection	Screw terminal for cables 1,5 mm ²
Housing	ABS RAL9010
Weight	ca. 70 g
Protection type	IP 30
Working range RH	0...98% RH in contaminant-free, non-condensing air
Working temperature °C	0...+50°C
Standards	CE, RoHs compliance



Model	Temperature	Humidity	Output
SACVV	-	-	0...10 V DC
SACVxV	Passive sensor (*)	-	0...10 V DC
SACVTV	●	-	0...10 V DC
SACVTHV	●	●	0...10 V DC
SACVC	-	-	4...20 mA
SACVxC	Passive sensor (*)	-	4...20 mA
SACVTC	●	-	4...20 mA
SACVHC	-	●	4...20 mA

Optional: suffix "D" version with display and/or suffix "R" relay version

(*) Replace "x" with the number of selected passive sensor:

"x"	Type of passive sensor
1	Pt100 (DIN EN 60751 Cl. B)
3	Ni1000 (TK6180)
5	NTC20k (±1%)
6	NTC10k (±1%) BETA 3435K

Electrical wirings

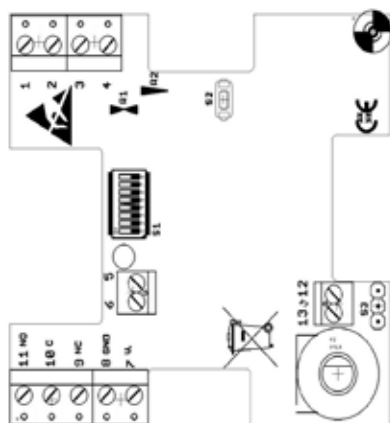

Output 0...10 V				Output 4...20 mA	
PIN	VOC/CO ₂	VOC/CO ₂ /T	VOC/CO ₂ /T/H	PIN	VOC/CO ₂
1	(VOC)	temp	temp	1	
2	ppm	(VOC)	humidity	2	
3	-	ppm	(VOC)	3	(VOC)
4	-	-	ppm	4	ppm
5	(passive poti)				
6	(passive poti)				
7	V+				
8	GND				
9	(relay NC)				
10	(relay C)				
11	(relay NO)				
12	(passive sensor)				
13	(passive sensor)				
S3	polarity R3				
S2	CO ₂ Manual adjustment to 400 ppm				

Dip-switch setting

Temperature range selection	Range	1	2	Humidity range selection	Range	3	4	5	6	CO ₂ range selection / setting	Range	7	8		
	-30...+70°C	OFF	OFF		Relative humidity	0...100%	OFF	OFF	OFF		OFF	CO ₂	0...2000 ppm	OFF	OFF
	-20...+80°C	OFF	ON		Absolute humidity	0 g/m ³ ...30g/m ³	ON	OFF	OFF		OFF	0...5000 ppm	ON	OFF	
	0...+50°C	ON	OFF		Mix ratio	0 g/m ³ ...50g/m ³	ON	ON	OFF		OFF	0...10000 ppm	OFF	ON	
	0...+100°C	ON	ON		Dew point	0 g/m ³ ...80g/m ³	ON	ON	ON		OFF	Enthalpy	0 kJ/kg...85kJ/kg	ON	ON

Autocalibration CO₂ sensor: The sensor must be mounted with the ventilation slots against the flow direction. The screw connector shall be installed in the direction of the ventilation slots.

The sensor shall be exposed to fresh air at least once a day, otherwise it will give incorrect readings on long term. The sensor requires 15 days of calibration to be adapted to the real values.

Dimension (mm)

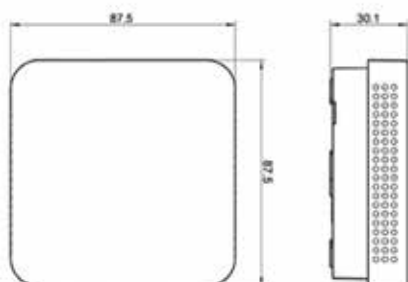



Description

The SDC CO₂ sensor measures air quality through the presence of carbon dioxide in air ducts in the range between 0...2000 ppm / 0...5000 ppm. The measurement of CO₂ concentration happens through a NDIR sensor that operates on an infrared basis and which compensates the presence of any impurity. The product can be provided with humidity or humidity/temperature sensor. Output 0 ... 10 Vdc or 4 ... 20 mA outputs.

Technical specifications

Measurement range CO₂	0...2000 / 0...5000 ppm
Accuracy CO₂	±60 ppm (0...2000 ppm) ±2% FS ±150 ppm (0...5000 ppm) ±2% FS
Accuracy temperature	± 0,3K (5...60°C) + 1% FS
Accuracy humidity	25°C ± 2% RH (20...80%RH) + 2% FS
Power supply	12...34 V AC/DC (20...34 V AC/DC with relay)
Power consumption	40...100 mA
Sensor setting up time	60 min.
Working resistance at 0...10 V DC	10...100 kOhm
Working resistance at 4...20 mA	50...500 Ohm
CO₂ sensitive element	NDIR self adjusting
Sensible element	Self-calibrating NDIR
Electrical connection	Screw terminal for cables 1,5 mm ²
Cable gland	M16 x 1.5 for cables ø 4 ... 10 mm
Protection type	IP65
Housing	PA6
Working range RH	0 ... 98% RH in clean, non-condensed air
Working temperature °C	0 ... + 50 ° C
Installation	PVC mounting flange (included)
Standards	CE, RoHs compliance



Models	Temperature	Humidity	Output
SDCV	-	-	0...10 V DC
SDCT(x)V*	•	-	0...10 V DC
SDCTH(x)V*	•	•	0...10 V DC
SDCC	-	-	4...20 mA
SDCTC	•	-	4...20 mA
SDCHC	-	•	4...20 mA

Optional: suffix "D" version with display and/or suffix "R" relay version

(*) Replace "X" with the number of selected passive sensor:

"X"	Type of passive sensor
1	Pt100 (DIN EN 60751 Cl. B)
3	Ni1000 (TK6180)
5	NTC20k (±1%)
6	NTC10k (±1%) BETA 3435K

The sensor must comply with the ventilation slots against the flow direction the measured medium are attached. An external indication of the location of ventilation slits offers inappropriate gland, which always towards the vents shows.

Generally the sensor should be supplied at least once per day with fresh air, as he regularly calibrates itself to this. This procedure prevents a long-term drift whereby the sensor is very stable.

The sensor requires 15 days of calibration time, during which time it adapts to the real values.



Electrical wirings

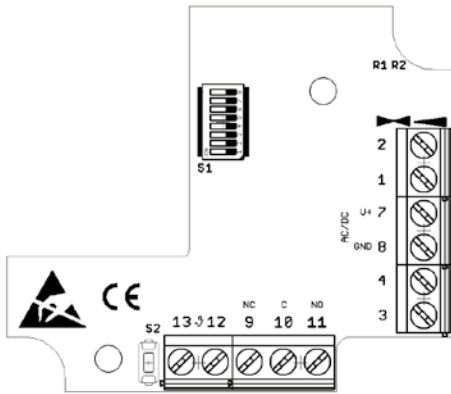

Output 0...10 Vdc				Output 4...20 mA			
PIN	CO ₂	CO ₂ /T	CO ₂ /T/H	PIN	CO ₂	CO ₂ /T	CO ₂ /H
1	ppm	temp	temp	1	-	-	-
2	-	ppm	humidity	2	-	-	-
3	-	-	ppm	3	ppm	temp	humidity
4	-	-	-	4	-	ppm	ppm
7	V+						
8	GND						
12	passive sensor						
13	passive sensor						
S2	CO ₂ Manual adjustment to 400 ppm						

Dip-switch setting

Temperature range selection	Range	1	2
	-30...+70°C	OFF	OFF
	-20...+80°C	ON	OFF
	0...+50°C	ON	ON
	0...+100°C	OFF	ON

Humidity range selection	Range	3	4	5	6	
	Relative humidity					
	0...100%	OFF	OFF	OFF	OFF	
	Absolute humidity					
	0 g/m ³ ...30g/m ³	ON	OFF	OFF	OFF	
	0 g/m ³ ...50g/m ³	ON	ON	OFF	OFF	
	0 g/m ³ ...80g/m ³	ON	ON	ON	OFF	
	Mix ratio					
	0 g/kg...30g/kg	OFF	OFF	OFF	ON	
	0 g/kg...50g/kg	OFF	OFF	ON	ON	
0 g/kg...80g/kg	OFF	ON	ON	ON		
Dew point						
0...+50°C	OFF	ON	ON	OFF		
-50...+100°C	ON	OFF	OFF	ON		
-20...+80°C	OFF	ON	OFF	ON		
Enthalpy						
0 kJ/kg...85kJ/kg	ON	ON	ON	ON		

CO ₂ range settings	Range	7	8	
	CO ₂ ranges			
	0...2000 ppm	OFF		
	0...5000 ppm	ON		
Auto-calibration				
Not activated		ON		
Activated		OFF		

The automatic self-calibration (ASC) algorithm independently generates a reference value by analyzing the measured CO₂ concentration over a certain period of time (approx. 7 days). This reference value is used to update the calibration curve. For correct use, it is necessary that the CO₂ sensor is regularly exposed to fresh air = 400 ppm at least 1 time per day for at least 30 minutes. The CO₂ sensor must be operated in continuous measurement mode during (ASC), switching it off will delay (ASC). To exclude gross calibration errors, the reference value is only accepted when the values are found to be plausible by the internal plausibility check of the sensor.

Dimensions (mm) and installation

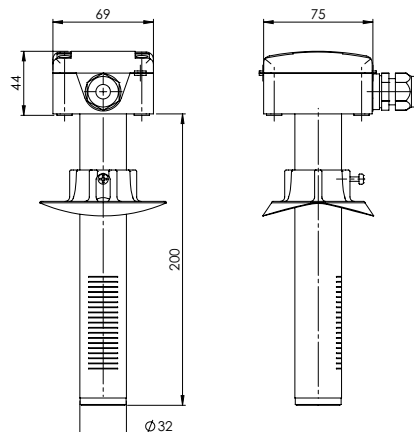



Description

The SDCM CO₂ sensor measures air quality through the presence of carbon dioxide in air ducts in the range between 0 and 2000 ppm. The measurement of CO₂ concentration happens through a NDIR sensor that operates on an infrared basis and which compensates the presence of any impurity. The product is provided with ModBus 485 output.

Technical specifications

Measurement range CO₂	0...2000 ppm
Accuracy CO₂	< ± 60 ppm +2% FS (at 25°C and 1013 mbar)
Accuracy temperature (*)	±0,3°C (5...60°C) + 1% FS
Accuracy humidity (*)	±2% RH (20...80%RH) + 2% FS
Power supply	12...24 V AC/DC
Consumption	max. 9 mA
Sensible element	NDIR self adjusting
Output	ModBus RS485 (ASCII/RTU)
Electrical connection	Screw terminal for cables 1,5 mm ²
Protection type	IP65
Working range RH	10...95% RH in contaminant-free, non-condensing air
Working temperature °C	-20...+50°C
Storage temperature	-20...+50°C
Installation	Mounting flange (included)
Standards	CE conformity, RoHS



Model	Temperature	Humidity
SDCM	-	-
SDCTM	•	-
SDCTHM	•	•

Measurement source

Unit	ModBus source	Gain
ppm CO ₂	10	10
Temperature °C	20	10
Relative humidity %u.r.	21	10
Absolute humidity g/m ³	22	10
Dewpoint °C	23	10
Enthalpy J	24	10

Electrical wirings

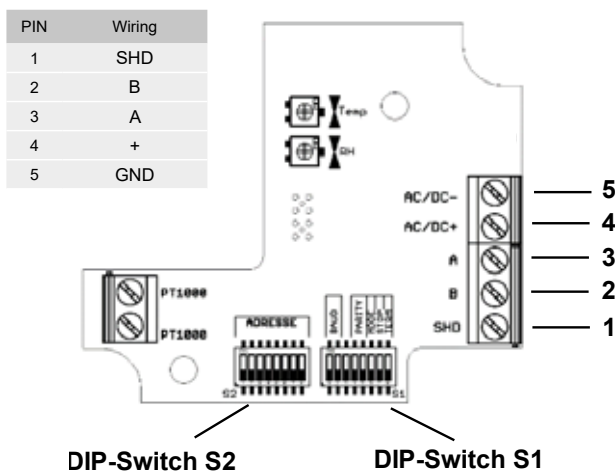

DIP Switch 1	Setting	1	2	3	4	5	6	7	8
	Baudrate								
	9600	OFF	OFF						
	19200	OFF	ON						
	38400	ON	OFF						
	57600	ON	ON						
Termination									
	nessuna								OFF
	120 Ω								ON
Parity									
	Even				OFF	OFF			
	Odd				OFF	ON			
	No parità				ON	OFF			
	No parità				ON	ON			
Modality									
	RTU							OFF	
	ASCII							ON	
Bit stop									
	1								OFF
	2								ON



Description

The SDV sensor measures air quality in air ducts in the range between 0...2000 ppm. The product can be provided with humidity or humidity/temperature sensor. Output 0 ... 10 V DC or 4 ... 20 mA outputs.

Technical specifications

Measurement range VOC	0...2000 ppm
Measurement range °C (optional)	see configuration
Accuracy temperature (*)	±0,3°C (5...60°C) + 1% FS
Measurement range RH (optional)	see configuration
Accuracy humidity (*)	±2% RH (20...80%RH) + 2% FS
Power supply	12...34 V AC/DC (20...34 V AC/DC with relay)
Power consumption	40...100 mA
Working resistance at 0...10 V DC	10...100 kOhm
Working resistance at 4...20 mA	50...500 Ohm
Calibration (corresponds)	Good air approx 1 Vdc ... 4 mA = 250 ppm CO ₂ equivalent 5 Vdc ... 12 mA = 1175 ppm CO ₂ equivalent 10 Vdc ... 20 mA = 2000 ppm CO ₂ equivalent
Electrical connection	Screw terminal for cables 1,5 mm ²
Protection type	IP65
Working range RH	0...98% RH in contaminant-free, non-condensing air
Working temperature °C	0...+50°C
Installation	Mounting flange (included)
Standards	CE conformity, RoHS



Models	Temperature	Humidity	Output
SDVV	-	-	0...10 V DC
SDVTV	•	-	0...10 V DC
SDVTHV	•	•	0...10 V DC
SDVC	-	-	4...20 mA
SDVTC	•	-	4...20 mA
SDVHC	-	•	4...20 mA

Optional: suffix "R" relay version

Electrical wirings

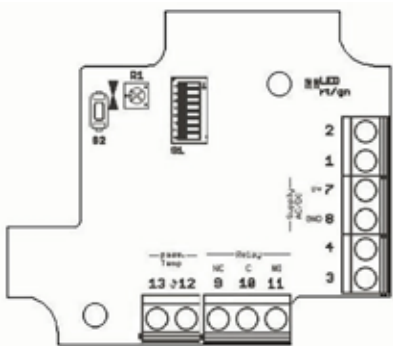

Output 0...10 Vdc				Output 4...20 mA			
PIN	VOC	VOC/T	VOC/T/H	PIN	VOC	VOC/T	VOC/H
1	ppm	temp	temp	1	-	-	-
2	(VOC)	ppm	humidity	2	-	-	-
3	-	(VOC)	ppm	3	ppm	temp	humidity
4	-	-	(VOC)	4	(VOC)	ppm	ppm
5	passive potentiometer						
6	passive potentiometer						
7	V+						
8	GND						
9	relay NC						
10	relay C						
11	relay NO						
12	passive sensor						
13	passive sensor						
R1	temp. adjustment						



Dip-switch setting

Temperature range selection			Humidity range selection							
Range	1	2	Range	3	4	5	6	7	8	
-30...+70°C	OFF	OFF	Relative humidity							
-20...+80°C	ON	OFF	0...100%	OFF	OFF	OFF	OFF	-	-	
0...+100°C	OFF	ON	Absolute humidity							
0...+50°C	ON	ON	0 g/m ³ ...30g/m ³	ON	OFF	OFF	OFF	-	-	
			0 g/m ³ ...50g/m ³	ON	ON	OFF	OFF	-	-	
			0 g/m ³ ...80g/m ³	ON	ON	ON	OFF	-	-	
			Mix ratio							
			0 g/kg...30g/kg	OFF	OFF	OFF	ON	-	-	
			0 g/kg...50g/kg	OFF	OFF	ON	ON	-	-	
			0 g/kg...80g/kg	OFF	ON	ON	ON	-	-	
			Dew point							
			0...+50°C	OFF	ON	ON	OFF	-	-	
			-50...+100°C	ON	OFF	OFF	ON	-	-	
			-20...+80°C	OFF	ON	OFF	ON	-	-	
			Enthalpy							
			0 kJ/kg...85kJ/kg	ON	ON	ON	ON	-	-	

Through the necessary heating-up phase it will take about 60 minutes until the sensor emits a signal. In this phase, the sensor should be exposed to the fresh air, since it takes this as a reference. If you take away the supply voltage short he needed again for 60 minutes. Generally the sensor should at least once per day to be supplied with fresh air, as he regularly calibrates itself to this. This procedure prevents a long-term drift whereby the sensor is very stable.

Measuring behaviour

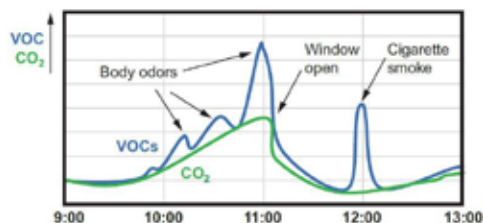

Dimensions (mm) and installation





Description

The SDVM sensor measures air quality in air ducts in the range between 450...2000 ppm. The product can be provided with humidity or humidity/temperature sensor. ModBus 485 output.

Technical specifications

Measurement range VOC	450...2000 ppm
Accuracy temperature	±0,3°C (5...60°C) + 1% FS
Accuracy humidity	±2% RH (20...80%RH) + 2% FS
Power supply	12...34 V AC/DC
Power consumption	40...100 mA
Electrical connection	Screw terminal for cables 1,5 mm ²
Protection type	IP65
Working range RH	0...98% RH in contaminant-free, non-condensing air
Working temperature °C	0...+50°C
Installation	Mounting flange (included)
Standards	CE conformity, RoHS



Models	Temperature	Humidity
SDVM	-	-
SDVTM	•	-
SDVTHM	•	•

Measurement source

Unit	ModBus source	Gain
Temperature °C	20	10
Relative humidity %u.r.	21	10
Absolute humidity g/m ³	22	10
Dewpoint °C	23	10
Enthalpy J	24	10
ppm VOC	30	10

Electrical wirings

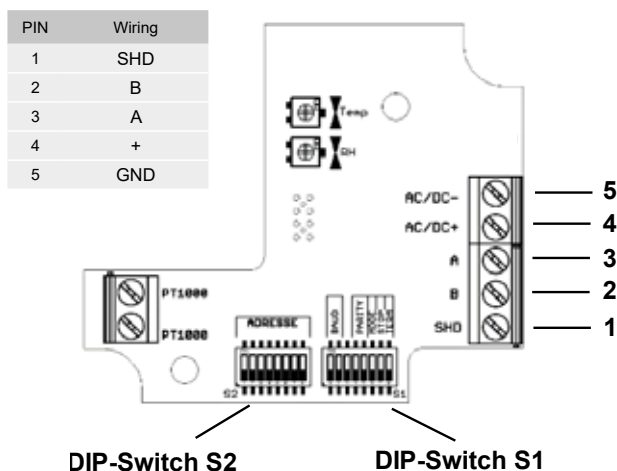

DIP Switch 1	Setting	1	2	3	4	5	6	7	8
	Baudrate								
	9600	OFF	OFF						
	19200	OFF	ON						
	38400	ON	OFF						
	57600	ON	ON						
Termination									
	nessuna								OFF
	120 Ω								ON
Parity									
	Even				OFF	OFF			
	Odd				OFF	ON			
	No parità				ON	OFF			
	No parità				ON	ON			
Modality									
	RTU							OFF	
	ASCII							ON	
Bit stop									
	1								OFF
	2								ON



Description

The relative pressure transmitter PTD series with ceramic measuring cell is used to measure relative pressures of non-aggressive media. Possible fields of application are building automation, industrial, pneumatic and hydraulic sectors. The standard series covers various measurement ranges (see schedule) with linear output signals 4 ... 20 mA or 0 ... 10 V DC. The resistant stainless steel case is available with two connectors and has an IP65 protection class.

Technical specifications

Power supply	Output 4...20 mA: 24 V DC / Output 0...10 V 24 V AC/DC
Output signal	0 ... 10 V DC or 4 ... 20 mA
Burst pressure	x 2,5 FS
Linearity	≤ 1% of FS
Hysteresis	≤ 0,5% of FS
Working temperature	0 ... 85°C
Thread	G 1/2", G 1/4"
Electrical connection	Connector DIN EN 175301-803-A
Housing	Stainless steel Aisi 303
Protection class EN 60529	IP65
Standards	CE, 2011/65/EU (RoHS II)



Code matrix

Configurable pressure range	0... 0,16 MPa	(0... 1,6 bar)	PTD	01	
	0... 0,25 MPa	(0... 2,5 bar)		02	
	0... 0,4 MPa	(0... 4 bar)		03	
	0... 0,6 MPa	(0... 6 bar)		04	
	0... 1 MPa	(0... 10 bar)		05	
	0... 1,6 MPa	(0... 16 bar)		06	
	0... 2,5 MPa	(0... 25 bar)		07	
	0... 4 MPa	(0... 40 bar)		08	
	0... 6 MPa	(0... 60 bar)		09	
	-0,1... 0 MPa	(-1... 0 bar)		10	
	-0,1... 0,06 MPa	(-1... 0,6 bar)		11	
	-0,1... 0,15 MPa	(-1... 1,5 bar)		12	
	-0,1... 0,3 MPa	(-1... 3 bar)		13	
	-0,1... 0,5 MPa	(-1... 5 bar)		14	
	-0,1... 0,9 MPa	(-1... 9 bar)		15	
	-0,1... 1,5 MPa	(-1... 15 bar)		16	
	-0... -0,1 MPa	(-0... -1 bar)		17	
Thread	G1/4"			1	
	G1/2"			2	
Output signal	0...10 V DC, 3 wire, linear				V
	4...20 mA, 2 wire, linear				C



Electrical wirings

DIN EN 175301-803-A

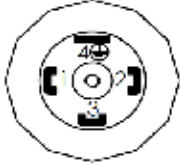

Output 4...20 mA		Output 0...10 V	
Pin	Connection	Pin	Connection
1	+IN	1	+IN
2	OUT	2	GND
3		3	+OUT
4		4	

Dimensions (mm)

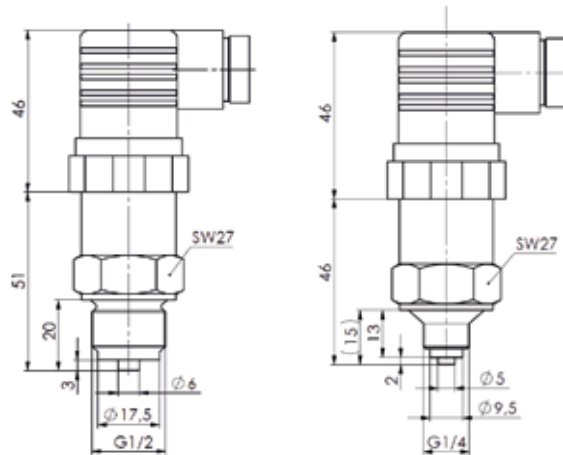

Description



The differential pressure transmitters of the PTR series are used to measure differential pressure, overpressure and vacuum. They provide one adjustable pressure range and one output signal. Monitoring of gaseous, non-aggressive media. Possible usage areas are: Building automation, air conditioning systems and clean room monitoring, valve and flap control, filter, ventilator and blower monitoring, control of air flows.

Technical data

Supply voltage	18 ... 30 V AC/DC (only DC for 2-wire version)
Output signal	0 ... 10 V or 4 ... 20 mA
Load for 4 ... 20mA output	20 ... 500 Ohm
Max. current draw	< 40 mA (<21 mA for 2-wire version)
Pressure medium	Air and non-aggressive gases
Linearity and hysteresis error	≤ ± 1% of FS
Working temperature	-40 ... 50°C
Storage temperature	-40 ... 70°C
Typical long-term stability	≤ ± 0,5 % of ± 2,5 % of FS/year, depending on pressure range
Repetition accuracy	≤ ± 0,2 % of FS
Position dependence	≤ ± 0,02 % of FS/g
Humidity	0 ... 95 % RH, non-condensing
Response time, selectable	0,1 - 1,0s
Process connection	6 mm hose connection
Electrical connection	Spring terminals for wires and leads up to 1,5 mm ²
Mounting	Screw mounting with serrated screws
Housing material	ABS
Housing dimensions	ca. Ø 66 x 28 mm
Weight	50 g
Cable conduit for protection cap	M12x1,5 threaded connection, made of polyamide
Protection class EN 60529	IP54
Conformity	EN 60770, EN 61326, 2011/65/EU (RoHS II)
Optional	UL, conforms to UL Std. 61010-1, conforms to CSA Std. C22.2 No. 61010-1



Model	Range	Overload capacity	Bursting pressure	Temperature error
PTR2..	0... 100 Pa (0... 1,0 mbar)	60 kPa	100 kPa	≤ ± 2,5 % of full range
PTR3..	0... 250 Pa (0... 2,5 mbar)	60 kPa	100 kPa	≤ ± 2,5 % of full range
PTR4..	0... 500 Pa (0... 5,0 mbar)	60 kPa	100 kPa	≤ ± 2,5 % of full range
PTR5..	0... 1000 Pa (0... 10 mbar)	75 kPa	125 kPa	≤ ± 1,0 % of full range
PTRM..	0... 1,6 kPa (0... 16 mbar)	85 kPa	135 kPa	≤ ± 1,0 % of full range
PTR6..	0... 2,5 kPa (0... 25 mbar)	85 kPa	135 kPa	≤ ± 1,0 % of full range
PTR7..	0... 5 kPa (0... 50 mbar)	85 kPa	135 kPa	≤ ± 1,0 % of full range
PTR8..	0... 10 kPa (0... 100 mbar)	85 kPa	135 kPa	≤ ± 1,0 % of full range
PTR9..	0... 25 kPa (0... 250 mbar)	135 kPa	275 kPa	≤ ± 1,0 % of full range
PTRA..	0... 50 kPa (0... 500 mbar)	200 kPa	400 kPa	≤ ± 1,0 % of full range
PTRB..	0... 100 kPa (0... 1,0 bar)	200 kPa	400 kPa	≤ ± 1,0 % of full range
PTRF..	0... 250 kPa (0... 2,5 bar)	400 kPa	800 kPa	≤ ± 1,0 % of full range



Adjustable pressure range: The end of the pressure range can be reduced to 50% of its factory set full scale value simply by the use of a push-button.

Output signal: 0 ... 10 V or 4 ... 20 mA. Other signals on request.

Configurable response time: The response time of the output signal can be configured using a jumper. If the jumper is in place the response time is slow (factory setting), which is useful for suppressing brief pressure peaks. If the application requires a fast response time the jumper must be removed.

Easy offset calibration: The output signal can be calibrated to zero by pressing the push-button (pressure transmitter must be depressurised).

Volume flow measurement (optional): The shape of the output signal can be switched from linear to square root using a jumper in order to measure the volume flow via a differential pressure.

Reset: The transmitter can be reset to its factory setting, just by pressing the push-button for 10sec.

Measuring method: Piezoresistive pressure transducer

Mounting position: Can be mounted in any position. The self-compensating piezoresistive pressure transducer eliminates any possible mounting error.

Order matrix

Configurable pressure ranges	0... 100 Pa	(0... 1,0 mbar)	PTR	2
	0... 250 Pa	(0... 2,5 mbar)		3
	0... 500 Pa	(0... 5,0 mbar)		4
	0... 1000 Pa	(0... 10 mbar)		5
	0... 1,6 kPa	(0... 16 mbar)		M
	0... 2,5 kPa	(0... 25 mbar)		6
	0... 5 kPa	(0... 50 mbar)		7
	0... 10 kPa	(0... 100 mbar)		8
	0... 25 kPa	(0... 250 mbar)		9
	0... 50 kPa	(0... 500 mbar)		A
	0... 100 kPa	(0... 1,0 bar)		B
	0... 250 kPa	(0... 2,5 bar)		F
Output signal	0...10 V, 3-wire, linear			7
	4...20 mA, 3-wire, linear			D
	0...10 V, 3-wire, square rooted			L
	4...20 mA, 3-wire, square rooted			P
	4...20 mA, 2-wire, linear			2
	4...20 mA, 2-wire, square rooted			U
Optional	Suffix UL for models UL / CSA approval			

Electrical wiring

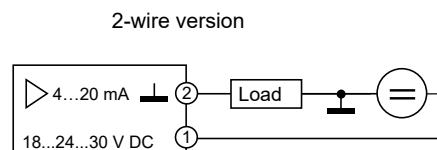
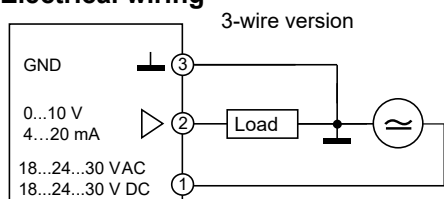

Dimensions (mm)

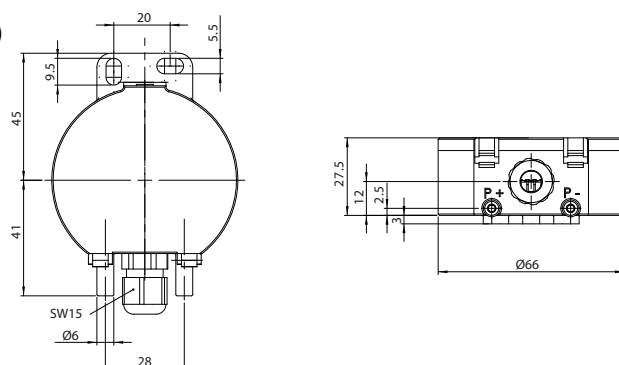

Description



Single and dual differential pressure transmitters of the PTS series are used to measure differential pressure, overpressure and vacuum. They provide eight adjustable pressure ranges, two output signals, Modbus and calibrated and temperature compensated measurements. Monitoring of gaseous, non-aggressive media. Possible usage areas are: Building automation, air conditioning systems and clean room monitoring, valve and flap control, filter, ventilator and blower monitoring, control of air flows.

Technical data

Supply voltage	24 VAC or 15...35 VDC
Power consumption	< 1,5 W
Output signal	0...10 VDC, 2...10 VDC, 0...5 VDC, 1...5 VDC, 4...20 mA
Current output	4...20 mA, maximum 500 Ohm
Voltage output	0...10 VDC or 0...5 VDC, minimum 1000 Ohm
Relay output	Max. rating 1A at 230 VAC
Sensing element	Piezoresistive silicon ceramic sensor
Pressure medium	Air and non-aggressive gases
Temperature compensation	-40 ... 110°C
Accuracy	± 0,25% of FS
Working temperature	-25 ... 70°C
Storage temperature	-30 ... 85°C
Pressure connection	6 mm hose connection
Electrical connection	Spring terminals for wires and leads up to 1,5 mm ²
Mounting	Screw mounting with serrated screws
Housing dimensions	151x85x50 mm
Weight	168...205 g
Cable conduit for protection cap	M16
Protection class EN 60529	IP54
Standards	CE conformity, RoHS



Order matrix

model	Range 1		Range 2		Output 1		Output 2		Option	
PTS	0	no	0	no	0	no	0	no	M	Modbus
	1	±250 Pa	1	±250 Pa	1	0...10 VDC	1	0...10 VDC	D	Display
	2	1.000 Pa	2	1.000 Pa	2	2...10 VDC	2	2...10 VDC	R	Relay*
	3	±1.000 Pa	3	±1.000 Pa	3	0...5 VDC	3	0...5 VDC		
	4	2.500 Pa	4	2.500 Pa	4	1...5 VDC	4	1...5 VDC		
	5	10.000 Pa	5	10.000 Pa	5	4...20 mA	5	4...20 mA		
	6	6.000 Pa	6	6.000 Pa						
	7	±6.000 Pa	7	±6.000 Pa						

*It is recommendable to order the relay version with display option.

Each range has its own 8 sub-ranges that can be selected by DIP switch, see schedule hereafter.



Range - Pa	sub-ranges - Pa
0 no	no
1 ±250	-25...+25, -50...+50, -100...+100, -250...+250, 0...25, 0...50, 0...100, 0...250
2 1.000	0...100, 0...200, 0...300, 0...400, 0...500, 0...600, 0...750, 0...1.000
3 ±1.000	-250...+250, -500...+500, -750...+750, -1.000...+1.000, 0...250, 0...500, 0...750, 0...1.000
4 2.500	0...100, 0...250, 0...500, 0...750, 0...1.000, 0...1.500, 0...2.000, 0...2.500
5 10.000	0...1k, 0...2k, 0...3k, 0...4k, 0...5k, 0...6k, 0...7,5k, 0...10k
6 6.000	0...500, 0...750, 0...1.000, 0...2.000, 0...3.000, 0...4.000, 0...5.000, 0...6.000
7 ±6.000	-1k...+1k, -2k...+2k, -3k...+3k, -6k...+6k, 0...1k, 0...2k, 0...3k, 0...6k

DIP Switch

- SW1, channel #1,2,3 selects port 1 sub-ranges
- SW1, channel #4 selects response time

Sub-ranges

DIP switch 1 and DIP switch 2 have the same subscales selectable from the table.

SW1/2	±250 Pa	1.000 Pa	±1.000 Pa	2.500 Pa	6.000 Pa	±6.000 Pa	10 KPa
	-25...25	0...100	-250...250	0...100	0...500	-1.000...1.000	0...1 KPa
	-50...50	0...200	-500...500	0...250	0...750	-2.000...2.000	0...2 KPa
	-100...100	0...300	-750...750	0...500	0...1.000	-3.000...3.000	0...3 KPa
	-250...250	0...400	-1.000...1.000	0...750	0...2.000	-6.000...6.000	0...4 KPa
	0...25	0...500	0...250	0...1.000	0...3.000	0...1.000	0...5 KPa
	0...50	0...600	0...500	0...1.500	0...4.000	0...2.000	0...6 KPa
	0...100	0...750	0...750	0...2.000	0...5.000	0...3.000	0...7.5 KPa
	0...250	0...1.000	0...1.000	0...2.500	0...6.000	0...6.000	0...10 KPa

Response time

SW1	Response
	FAST / 1 sec.
	SLOW / 4 sec.

In both cases, FAST or SLOW,
- output is mean of latest 10 measurements.

Output is updated:
- every 0.1 second in FAST mode
- every 0.4 second in SLOW mode



Transmitter hardware

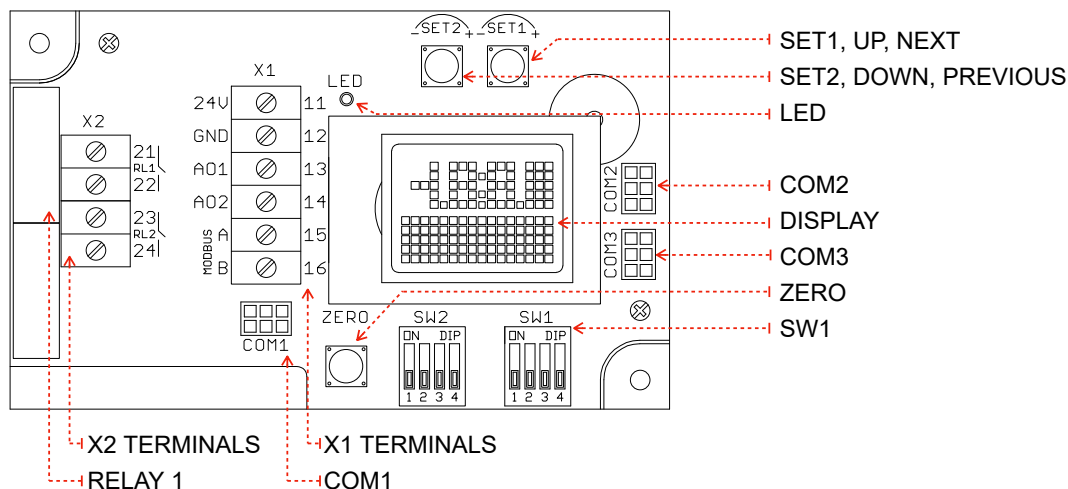

SET1	Main Screen Menu Mode	press min. 5 sec. for entering MENU increase the parameter or next selection
SET2	Menu Mode	decrease the parameter or previous selection
ZERO	Main Screen Menu Mode	press min. 5 sec. for setting ZERO next parameter and finally exit
LED	Working Modbus	blinks periodically blinks for each Modbus transmitting
DISPLAY		custom dot matrix display, please check page 6 for more information
COM	COM 1 COM 2 COM 3	service port service port service port
SW 1	# 1-2-3 # 4	sub-range selection for DP 1, see page 3 response time selection, see page 3
X1	11 24V Terminals 12 GND 13 AO1 14 AO2 15 modbus-A 16 modbus-B	14...35 VDC or 24 VAC ($\pm 5\%$, 50-60 Hz) ground for power and reference for outputs analog output 1 analog output 2 modbus communication positive pair modbus communication negative pair
X2	21-22	relay 1, dry contact, max. rating 1A @ 220 VAC
Relay 1	normally open	acts always for DP1

Electrical wiring

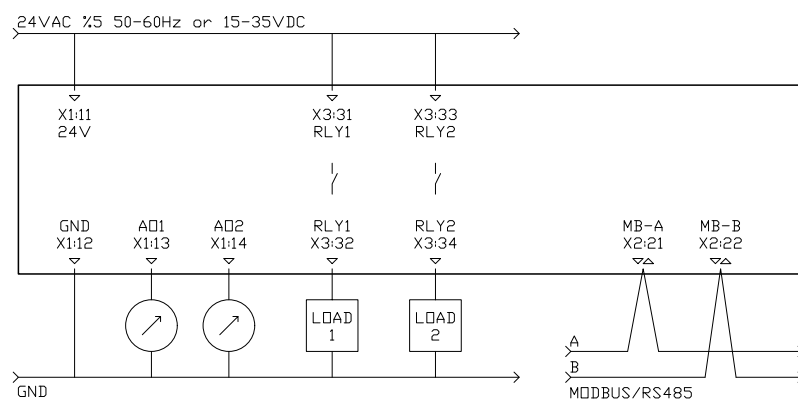

Relay contact rating is max. 1A at 230 VAC
We kindly advise using 24V for avoiding high voltage harmonics and external power relay for bigger loads
Please use shielded and twisted paired cables for Modbus connections



■ Display

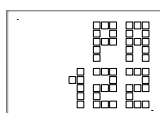

main screen
for Single DP version

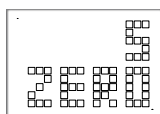

zeroing
counts down for 5 sec.
keep pressing ZERO button

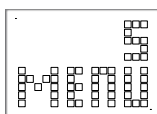

entering MENU
counts down for 5 sec.
keep pressing SET1 button

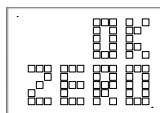

zeroing is OK

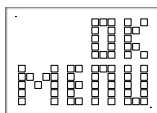

entered to MENU

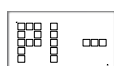

min. point, scale for DP

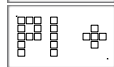

max. point, scale for DP

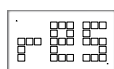

response time



FAST response, 1 sec.

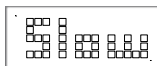

SLOW response, 4 sec.

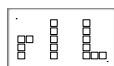

Relay, LOW point

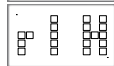

Relay, HIGH point

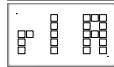

Relay, ACTION

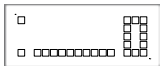

action 0,
always OFF



action 1,
ON between LOW and HIGH points

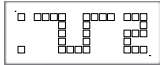

action 2,
OFF between LOW and HIGH points

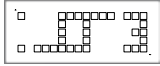

action 3,
ON over HIGH

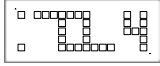

action 4,
ON under LOW



EXIT

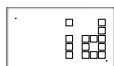

modbus address



baudrate



9.600



19.200



38.400



57.600



115.200

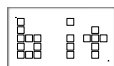

bit settings



databits: 8, parity: even, stopbit: 1



databits: 8, parity: none, stopbit: 1



databits: 8, parity: none, stopbit: 2



databits: 8, parity: odd, stopbit: 1



Menu

1. For entering MENU press SET1 button min. 5 sec.
2. ZERO button calls the next parameter
3. SET1 button increases the value or choses the next selection
4. SET2 button decreases the value or choses the previous selection
5. All parameters are listed below, due to options you may not see some of them
6. Any changed parameter or value is set while exiting Menu

Main Screen >> r1L >> r1H >> r1A >> EXIT

Actions for Relay and Buzzer

Action	under LOW	between LOW - HIGH	over HIGH
0	Open	Open	Open
1	Open	Closed	Open
2	Closed	Open	Closed
3	Open	hysteresis	Closed
4	Closed	hysteresis	Open

Modbus 485 protocol

Use Function 3 for Reading and Function 6 for Writing Holding Registers.

Register Table starts from Base 1. Default Settings: Modbus ID:1, 9600, 8bit, None, 1.

Register	R/W	min.	max.	Description
1	R & W	1	254	Modbus Address
2	R & W	0	4	Baudrate, 0: 9.600, 1: 19.200
3	R & W	0	3	Bit_Parity_Stop, 0: 8bit_None_1, 1: 8bit_None_2, 2: 8bit_Even_1, 3: 8bit_Odd_1
4	R	min. Pa	max. Pa	DP measurement as PASCAL
5	R			Blank
6	R	0	1	Relay, contact position, 0: OFF/Open, 1: ON/Closed
7	R & W	min. Pa	max. Pa	Relay, LOW Point
8	R & W	min. Pa	max. Pa	Relay, HIGH Point
9	R & W	0	4	Relay, Actions
10-20	R & W			Blank

Dimensions (mm)

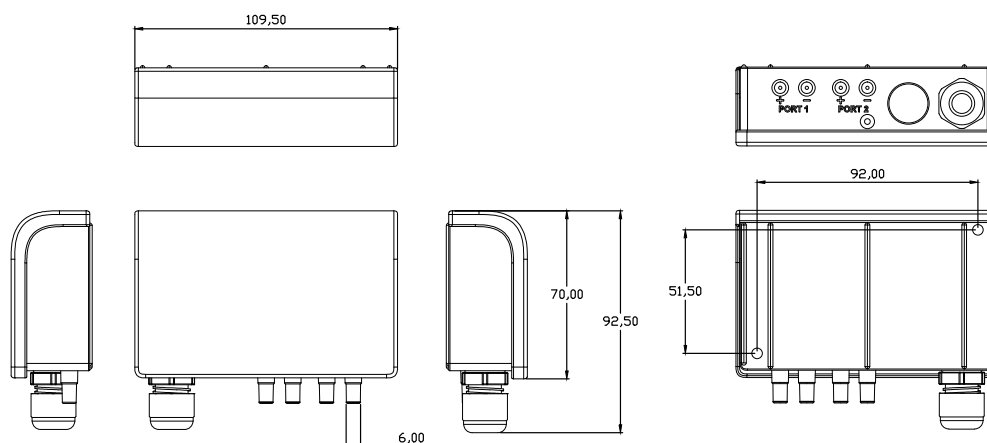

Description

The differential pressure transmitter serie PTG is used to measure differential pressure, overpressure and vacuum of gaseous, non-aggressive media. It provides 2 pressure ranges and 2 output signals, which are selectable by jumper. Possible fields of application are building automation and air conditioning systems, overpressure measurement in clean rooms and laboratories, measurement of constant pressure in VAV applications, dynamic filter and ventilator monitoring.

Technical specifications

Medium	Air, non-combustible and non-aggressive gases
Measurement range	See schedule
Linearity and hysteresis error	≤ ±1% of FS
Repetition accuracy	≤ ±0.2 % of FS
Response time	0,1 s or 1 s, selectable by jumper
Position dependence	≤ ±0,02% of FS/g
Long term stability	< ±0,5% final value/year
Offset calibration	The output signal can be calibrated to zero by pressing the M key.
Supply voltage	18...30 V AC / DC
Output signal	3-wire connection, with switching output. The factory setting is 0...10 V DC, but can be changed to 4-20 mA by removing the jumper. 2-wire connection 4...20 mA version is available upon request.
Switching output	npn transistor output for max. 30 V DC/100 mA
Electrical connection	Screw terminal block for wires and strands up to 1,5 mm ²
Display, optional	LED, 4 digits
Housing material	Housing with process connection P2 (-) Base part with process connection P1 (+)
Cable conduit	M16x1,5 connection made of polyamide
Housing dimensions	approx. 81x83x41 mm
Weight	approx. 125 g
Protection class	IP65
Working humidity	0...95% RH, non-condensing
Working temperature	0...+50°C
Storage temperature	-10...+70°C
Accessories	Connection set (PVC-hose 2 m Ø 6 with 2 ABS nippels and 4 screws) included
Installation	Screw fastening
Installation position	any
Standards	CE-conformity, RoHS
Optional	UL, conforms to UL Std. 61010-1, conforms to CSA Std. C22.2 No. 61010-1



Models	Measuring range	Max pressure
PTG1	-50...0...+50 Pa	60 kPa
PTG2	0...100 Pa, 0...250 Pa	60 kPa
PTG3	0...500 Pa, 0...1000 Pa	75 kPa
PTG4	0...1 kPa, 0...2,5 kPa	85 kPa
PTG5	0...5 kPa, 0...10 kPa	85 kPa
PTG6	0...25 kPa, 0...50 kPa	200 kPa
PTG9	-100...0...+100 Pa	60 kPa

Suffix A offset autocalibration
 Suffix D for models with display
 Suffix UL for models UL / CSA approval



Electrical wirings

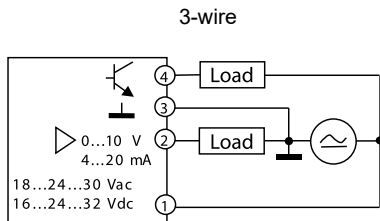

4	SA	Switching output, npn
3	GO	Ground G N D
2	Y	Output signal 0... 10V / 4... 20 mA
1	G	Supply voltage 24 VAC / VDC

Settings

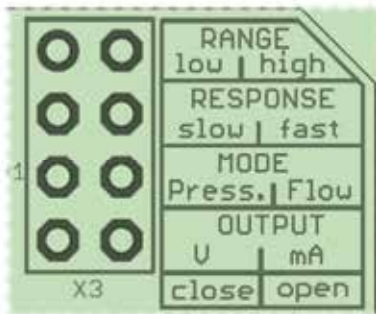

	Jumper (switched)	Aperto (open)
Range pressione (Pressure range)	Bassa (low)	Alta (high)
Risposta (Response)	Lenta (slow)	Veloce (fast)
Funzionamento (Mode)	Lineare (linear)	Quadratico (square root)
Segnale di uscita (Output signal)	0... 10 V	4...20 mA

Dimensions (mm)

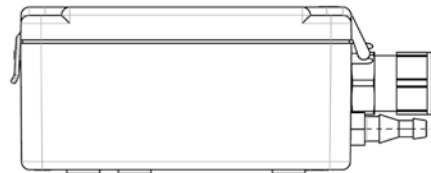
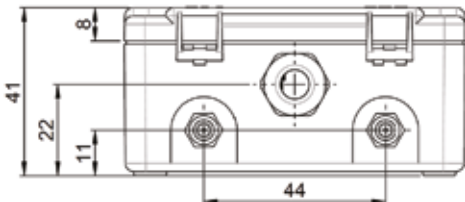

ABS nippel
(part of connection set APA3)

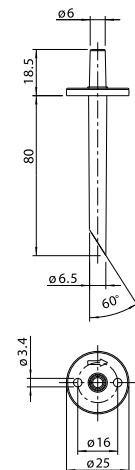
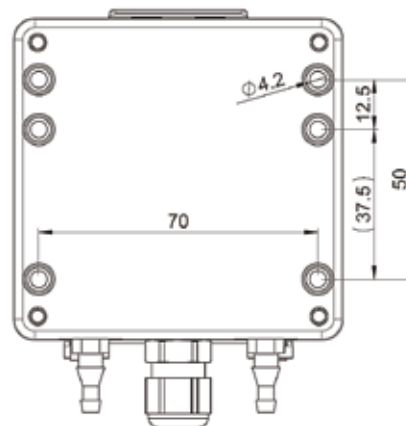
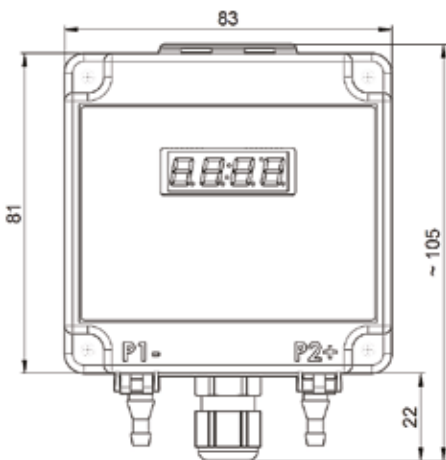



■ Programming version without display

In the version without display, you can program the switching value by acting in this way:

- 1 Apply the pressure or differential pressure at which you want the system switches
- 2 Press the „S“ button for 5 seconds until the LED flashes quickly.

At this point the switching value is saved and the LED will light while reaching the set pressure.

For recalibration remove both pressure tube, press the button „MODE/Offset“ for 5 seconds and than replase the pressure tube.

■ Programming display version

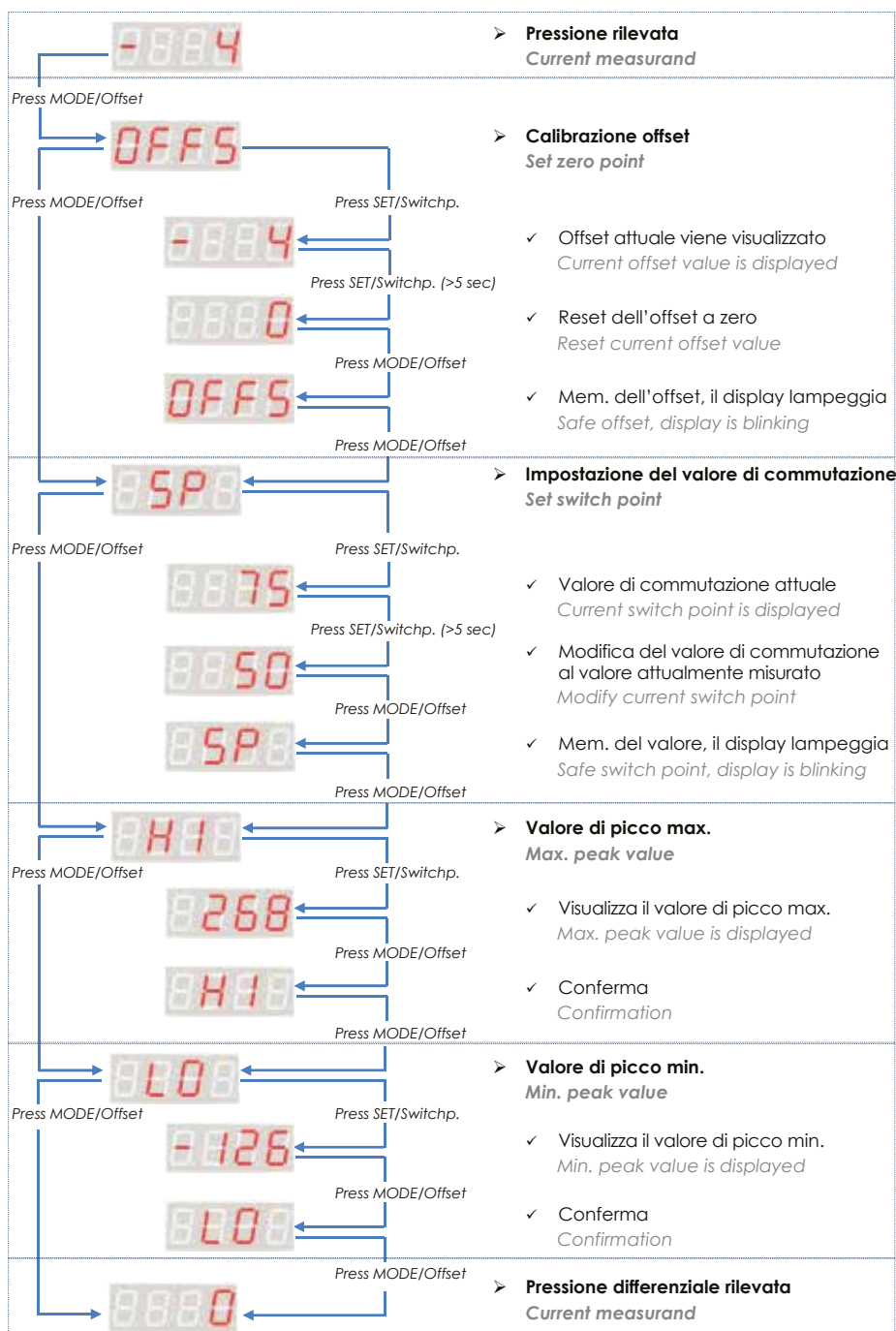

* Free from pipes or remove the cap from the two nozzles before proceeding with the offset re-calibration.



Description

The air differential pressure transmitter serie PTG and the velocity transmitter serie VTG are used to measure differential pressure, air flow volume and air flow speed.

The measured value can be the output and the parameterization on the device can be done via Modbus RTU data interface.

Possible fields of application are building automation and air conditioning systems, overpressure measurement in clean rooms and laboratories, measurement of constant pressure in VAV applications, dynamic filter and fan monitoring.

Technical specifications

Medium	Air, non-combustible and non-aggressive gases
Measurement range	See schedule
Linearity and hysteresis error	$\leq \pm 0,5\%$ of FS, min ± 1 Pa
Uncertainty (total error band w/o long-term and temperature effect)	$\pm 1 \%$ of FS, min ± 1 Pa
Response time	0,2...10 s
Long term stability PTGM, VTGM	$< \pm 1\%$ of FS
Long term stability PTGA, VTGA	n.r.
Supply voltage	18...30 V AC / DC
Output signal	Digital
Protocol	ModBus RS-485, RTU
Type, Address	Slave, 1...247
Baud rate	9600...115200 bd
Data bit, Stop bit	8, 1
Maximum current draw	< 230 mA
Electrical connection	Screw terminal block for wires and strands up to 1,5 mm ²
Display	LED, 4 digits
Housing material	ABS
Housing dimensions	Approx. 81x83x41 mm
Weight	Approx. 140 g
Protection class	IP65
Working humidity	0...95% RH, non-condensing
Working and storage temperature	
PTGM, VTGM	-20...+70°C
PTGA, VTGA	-10...+50°C
Accessories	Connection set (PVC-hose 2 m Ø 6 with 2 ABS nippels and 4 screws) included
Installation	Screw fastening
Installation position	Any
Standards	CE-conformity, RoHS



Setup

Configuration of air flow volume or air flow speed measurement

1. Select a calculation formula and enter a k-factor. Both dependents on the type of fan or measuring sensor.
 2. Or create a reference air flow volume or air flow speed, which is entered directly.
- The modbus is used to set the device. Please read the exact procedure in the installation manual.

Adjustable response time

The response time of the output signal can be variably set via Modbus.

Easy offset calibration

For PTGM and VTGM press the MODE/offset button or set via Modbus in an unpressurized state to adjust the offset to zero. The versions PTGA and VTGA perform an automated zero offset compensation.

Display

A red LED display shows the pressure value, air flow volume or air flow speed.

Mounting position

Can be mounted in any position. The zero offset calibration eliminates any possible position error.

Models



Pressure ranges for air differential pressure versions

Model	Pressure range	Overload capacity	Bursting pressure	Additional uncertainty with temperature (% FS/10K)	
				PTGM	PTGA
PTGAE	-25...0...+25 Pa	60 kPa	100 kPa	-	± 0,7
PTGxX	-50...0...+50 Pa	60 kPa	100 kPa	± 1,0	± 0,5
PTGxW	-100...0...+100 Pa	60 kPa	100 kPa	± 0,7	± 0,3
PTGA1	0...50 Pa	60 kPa	100 kPa	-	± 0,7
PTGx2	0...100 Pa	60 kPa	100 kPa	± 0,7	± 0,5
PTGx3	0...250 Pa	60 kPa	100 kPa	± 0,5	± 0,3
PTGx4	0...500 Pa	75 kPa	125 kPa	± 0,3	n.r.
PTGx5	0...1000 Pa	75 kPa	135 kPa	± 0,3	n.r.
PTGx7	0...5000 Pa	85 kPa	135 kPa	± 0,3	n.r.
PTGx8	0...10 kPa	85 kPa	135 kPa	± 0,3	n.r.
PTGx9	0...25 kPa	200 kPa	400 kPa	± 0,3	n.r.
PTGxA	0...50 kPa	200 kPa	400 kPa	± 0,3	n.r.
PTGxB	0...100 kPa	200 kPa	400 kPa	± 0,3	n.r.

Order matrix

Offset calibration			manual	PTGM	
			automatic	PTGA	
Configurable pressure ranges	-25...0...+25 Pa	only available as PTGA			E
	-50...0...+50 Pa		X		
	-100...0...+100 Pa		W		
	0...50 Pa		1		
	0...100 Pa		2		
	0...250 Pa		3		
	0...500 Pa		4		
	0...1000 Pa		5		
	0...5000 Pa		7		
	0...10 kPa		8		
	0...25 kPa		9		
	0...50 kPa		A		
	0...100 kPa		B		

Pressure ranges for air flow volume or air flow speed versions

Model	Pressure range	Overload capacity	Bursting pressure	Additional uncertainty with temperature (% FS/10K)	
				VTGM	VTGA
VTGA1	0...50 Pa	60 kPa	100 kPa	-	± 0,7
VTGx2	0...100 Pa	60 kPa	100 kPa	± 1,0	± 0,5
VTGx3	0...250 Pa	60 kPa	100 kPa	± 0,7	± 0,3
VTGx4	0...500 Pa	75 kPa	125 kPa	± 0,5	n.r.
VTGx5	0...1000 Pa	75 kPa	135 kPa	± 0,3	n.r.
VTGx7	0...5000 Pa	85 kPa	135 kPa	± 0,3	n.r.
VTGx8	0...10 kPa	85 kPa	135 kPa	± 0,3	n.r.

Order matrix

Offset calibration			manual	VTGM	
			automatic	VTGA	
Configurable pressure ranges	0...50 Pa	only available as VTGA			1
	0...100 Pa		2		
	0...250 Pa		3		
	0...500 Pa		4		
	0...1000 Pa		5		
	0...5000 Pa		7		
	0...10 kPa		8		
	Unit of display		Air flow volume	m ³ /h; m ³ /s; cfm; l/s	
	Air flow speed	m/s; ft/min			B

PTG / VTG



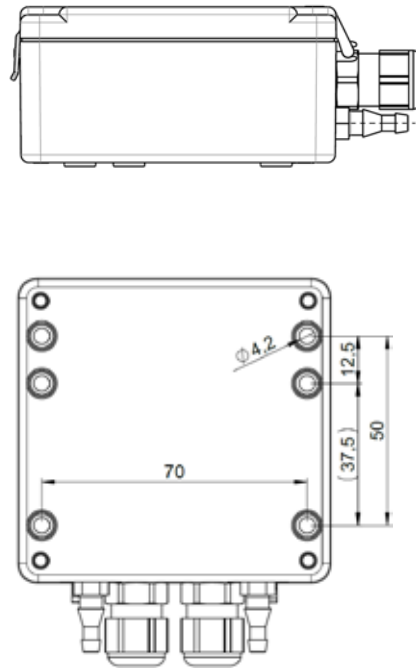
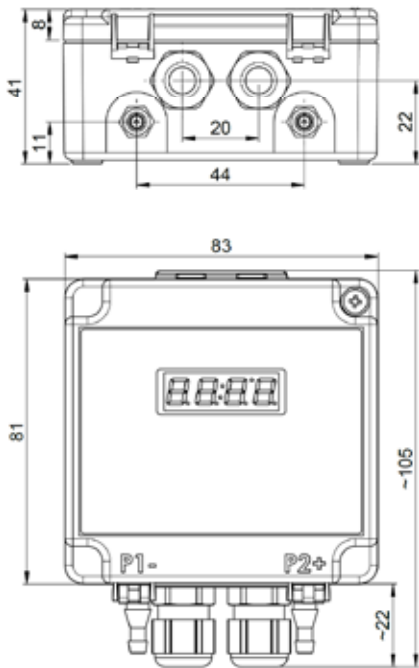

■ Dimensions (mm)

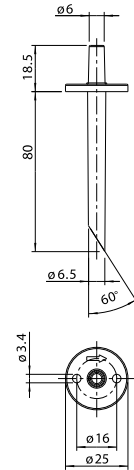

ABS nippel
(part of connection set APA3)

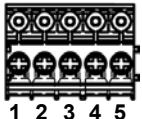

Terminal assignments

Plug-in terminals 2 x 5-pole			
		1 2 3 4 5	1 2 3 4 5
1	in	Supply voltage (18...30 VAC / VDC)	
2	in	Ground (GND) Common	
3	in	A / Data + (D0)	
4	in	B / Data - (D1)	
5	in	Shield	
1	out	Supply voltage (18...30 VAC / VDC)	
2	out	Ground (GND) Common	
3	out	A / Data + (D0)	
4	out	B / Data - (D1)	
5	out	Shield	



Air differential pressure transmitter

Description

The differential pressure transmitter serie PTM is used to measure differential pressure, overpressure and vacuum of gaseous, non-aggressive media. It provides 2 pressure ranges and 2 output signals, which are selectable by jumper.

Possible fields of application are building automation and air conditioning systems, overpressure measurement in clean rooms and laboratories, measurement of constant pressure in VAV applications, dynamic filter and ventilator monitoring.

Technical specifications

Medium	Air, non-combustible and non-aggressive gases
Measurement range	See schedule
Linearity and hysteresis error	$\leq \pm 1\%$ of FS
Repetition accuracy	$\leq \pm 0.2\%$ of FS
Response time	0.1 s or 1 s, selectable by jumper
Position dependence	$\leq \pm 0.02\%$ of FS/g
Long term stability	$< \pm 0.5\%$ final value/year
Offset calibration	The output signal can be calibrated to zero by pressing the M key.
Supply voltage	18...30 V AC / 16...32 V DC
Output signal	3-wire connection, with switching output. The factory setting is 0-10 V DC, but can be changed to 4-20 mA by removing the jumper. 2-wire connection 4-20 mA version is available upon request.
Switching output	npn transistor output for max. 30 V DC/100 mA
Electrical connection	Screw terminal block for wires and strands up to 1,5 mm ²
Display, optional	LED, 4 digits
Housing material	Housing with process connection P2 (-) Base part with process connection P1 (+)
Cable conduit	M16x1,5 connection made of polyamide
Housing dimensions	approx. $\varnothing 85 \times 58$ mm
Weight	approx. 150 g
Protection class	IP54
Working humidity	0...95% RH, non-condensing
Working temperature	0...+50°C
Storage temperature	-40...+70°C
Accessories	Connection set (PVC-hose 2 m $\varnothing 6$ with 2 ABS nippels and 4 screws) included and snap-on plastic brackets optionally
Installation	Screw fastening
Installation position	any
Standards	CE-conformity, RoHS



Models	Measuring range	Max pressure
PTM1	-50...0...+50 Pa	20 kPa
PTM2	0...100 Pa, 0...250 Pa	20 kPa
PTM3	0...500 Pa, 0...1000 Pa	20 kPa
PTM4	0...1 kPa, 0...2,5 kPa	40 kPa
PTM5	0...5 kPa, 0...10 kPa	60 kPa
PTM6	0...25 kPa, 0...50 kPa	300 kPa
PTM9	-100...0...+100 Pa	20 kPa

Suffix D for models with display

Models with UL Std. 61010-1 approval and CSA Std. C22.2 No. 61010-1 certification available upon request.



Electrical wirings

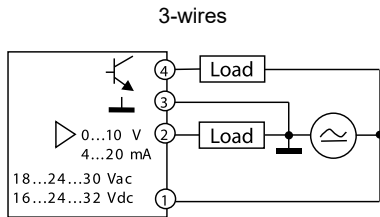

4	SA	Switching output, npn
3	GO	Ground G N D
2	Y	Output signal 0...10V / 4...20 mA
1	G	Supply voltage 24 VAC / VDC

Setting

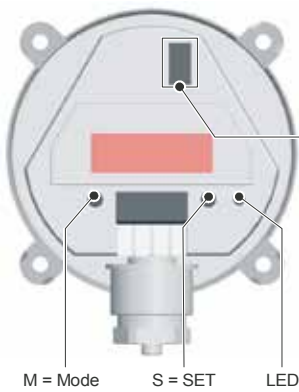

	Jumper (switched)	Aperto (open)
Range pressione (Pressure range)	Bassa (low)	Alta (high)
Risposta (Response)	Lenta (slow)	Veloce (fast)
Funzionamento (Mode)	Lineare (linear)	Quadratico (square root)
Segnale di uscita (Output signal)	0...10 V	4...20 mA

Dimensions (mm)

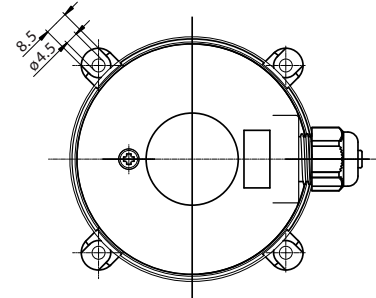
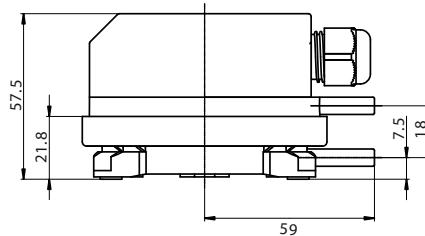
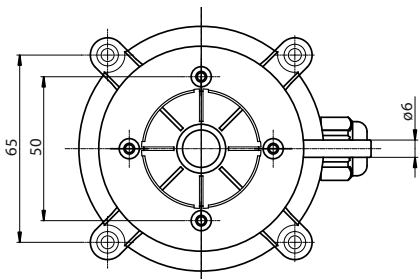

APA1 Snap-on plastic bracket, L-shaped

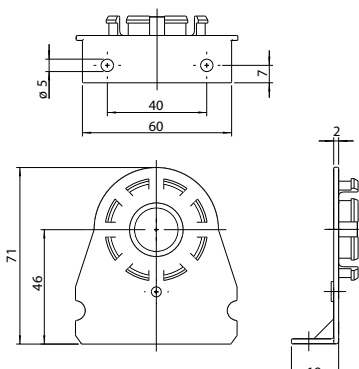

APA2 Snap-on plastic bracket, S-shaped

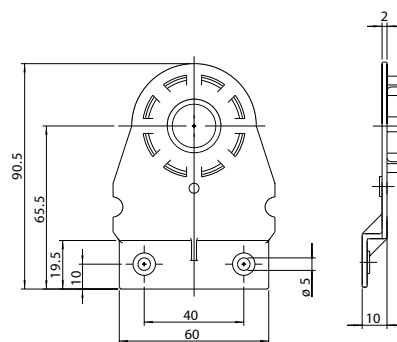

ABS nipple (part of connection set APA3)

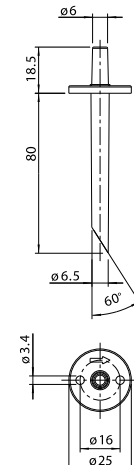



■ Programming version without display

In the version without display, you can program the switching value by acting in this way:

1 Apply the pressure or differential pressure at which you want the system switches

2 Press the „S“ button for 5 seconds until the LED flashes quickly.

At this point the switching value is saved and the LED will light while reaching the set pressure.

■ Programming display version

Pulsante / switch	Display	Passo / step	Note / Information
	250		Pressione rilevata / current measured value
Press >M<			
	OFFS		Calibrazione offset* / Offset calibration*
Press >M<		Press >S<	Visualizza attuale offset / Show actual offset value
	-3		
		Press >S<(5 sec)	Ritaratura offset / recalibration of offset
	0		
		Press >M<	Memorizzazione offset, il display lampeggia / Store offset, Display blinking for confirmation
	OFFS		
Press >M<			
	SP		Impostazione valore di commutazione / Setting switching level
Press >M<		Press >S<	Visualizza attuale valore di commutazione / Show actual switching level
	112		
		Press >S<(5 sec)	Modifica valore di commutazione / Modify switching level
	112		
		Press >M<	Memorizzazione valore di commutazione, il display lampeggia / Store switching level, Display blinking for confirmation
	SP		
Press >M<			
	HI		Valore di picco max. / peak value high
Press >M<		Press >S<	Visualizza il valore di picco max. / show peak value high
	240		
		Press >M<	Ritorno / return
	HI		
Press >M<			
	LO		Valore di picco min. / peak value low
Press >M<		Press >S<	Visualizza il valore di picco min. / show peak value low
	-50		
		Press >M<	Ritorno / return
	LO		
Press >M<			
	250		Pressione rilevata / current measured value

* Free from pipes or remove the cap from the two nozzles before proceeding with the offset re-calibration.

Description

The transmitters of the PTV series are used to measure volume flow, differential pressure, overpressure and vacuum. A jumper enables switching between volume flow and pressure measurement. Monitoring of gaseous, non-combustible and non-aggressive media. Possible usage areas are: Building automation and air conditioning systems, overpressure measurement in clean rooms and laboratories, measurement of constant pressure in VAV applications, dynamic filter and ventilator monitoring

Technical specification

Power supply	18 ... 30 VAC/DC
Output signal	0 ... 10 V or 4 ... 20 mA
Load for 4 ... 20 mA output	20...500 Ω
Load for 0 ... 10 V output	≥ 1k Ω (≥10mA)
Units, selectable	m³/h; m³/s; cfm; l/s
K factor	0,001...9,9 x 10 ⁵
Switching output	Transistor, maximum switching capacity of 30 VDC / 100 mA
Working temperature	0 ... 50°C
Storage temperature	-10 ... 70°C
Typical long-term stability (Pressure range)	± 1,0 % from end value / year
Linearity error incl. hysteresis and repetition accuracy (Pressure range)	≤ ± 1 % del FS, min ± 1 Pa
Humidity	0 ... 95 % RH, non-condensing
2 response times, selectable between 0.1 s and 20 s	0,1 - 1,0s
Process connection P1 and P2	Ø 6 mm
Electrical connection	Plug-in terminals for wires and strands up to 1.5 mm² with Cap nut
Housing material	ABS
Housing dimensions	ca. 81 x 43 x 41 mm
Weight	125 g
Protection class acc. to EN 60529	IP 65
Standards	EN 60770, EN 61326, 2014/30/EU, 2011/65/EU (RoHS II)



Models	Range	Overload capacity	Bursting pressure	Temperature error
PTV1..	0... 50 Pa (0... 0,5 mbar)	60 kPa	100 kPa	≤ ± 3,0 % of full range
PTV2..	0... 100 Pa (0... 1,0 mbar)	60 kPa	100 kPa	≤ ± 2,0 % of full range
PTV3..	0... 250 Pa (0... 2,5 mbar)	60 kPa	100 kPa	≤ ± 2,5 % of full range
PTV4..	0... 500 Pa (0... 5,0 mbar)	75 kPa	125 kPa	≤ ± 2,5 % of full range
PTV5..	0... 1000 Pa (0... 10 mbar)	85 kPa	135 kPa	≤ ± 1,5 % of full range
PTV7..	0... 5 kPa (0... 50 mbar)	85 kPa	135 kPa	≤ ± 1,0 % of full range
PTV8..	0... 10 kPa (0... 100 mbar)	85 kPa	135 kPa	≤ ± 1,0 % of full range

Characteristics and settings

- Select a calculation formula and enter the k-factor. The k-factor can be found, for example, in documentation provided by the manufacturer of the ventilator or the probe.
- The output signal can be changed between 0...10 Volt and 4 ... 20 mA by removing a jumper.
- To give a switch signal at an user defined pressure level the transmitter has an adjustable transistor switching output (npn NO) with a maximum switching capacity of 30 Vdc/100 mA.
- The response time of the output signal can be configured using a jumper. If the jumper is in place the response time is slow (factory setting), which is useful for suppressing brief pressure peaks. If the application requires a fast response time the jumper must be removed.
- If there are any drifts on output, the transmitter can be adjusted by pressing the Offset-button to zero.
- The differential pressure transducer can be mounted in any position.



Order matrix

Configurable pressure range	0... 50 Pa	(0... 0,5 mbar)	PTV	1
	0... 100 Pa	(0... 1,0 mbar)		2
	0... 250 Pa	(0... 2,5 mbar)		3
	0... 500 Pa	(0... 5,0 mbar)		4
	0... 1000 Pa	(0... 10 mbar)		5
	0... 5 kPa	(0... 50 mbar)		7
	0... 10 kPa	(0... 100 mbar)		8
	Volume flow unit	m³/h; m³/s; cfm; l/s		

Formula configuration

- 1) Select a calculation formula and enter the k-factor (jumper 1 open): This procedure is used when the k-factor is known. The k-factor can be found, for example, in documentation provided by the manufacturer of the ventilator or the probe. Use the menu guide on the device for configuration.
- 2) Creating reference volume flow (jumper 1 plugged in): Create a reference volume flow to configure the device. Use **FL** in the menu guide for entry - see description in the operating instructions.

Selection on device	Manufacturer, e.g.	Formula in data sheet of manufacturer
F 1	Ebm-Papst, Ziehl-Abegg	$q = k \cdot \sqrt{\Delta p}$
F 2	Ziehl-Abegg	$q = \sqrt{\frac{\rho_{20}}{\rho}} \cdot k \cdot \sqrt{\Delta p}$
F 3	Nicotra-Gebhardt, Rosenberg	$q = k \cdot \sqrt{\frac{2}{\rho} \cdot \Delta p}$
F 4	Fläkt Woods	$q = \frac{1}{k} \cdot \sqrt{\Delta p}$

Diagramm

Volume flow (Jumper 3 open)

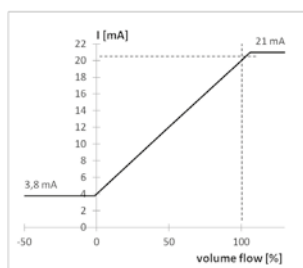
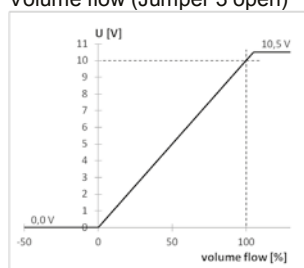

Pressure (Jumper 3 plugged in)

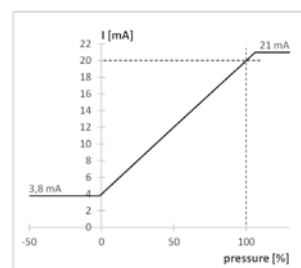
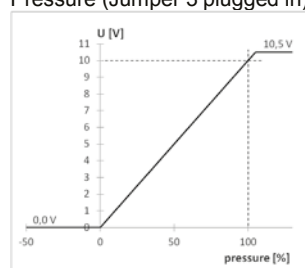

Terminal assignments

3-wire with switching output

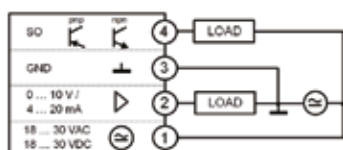

Plug-in terminals, 4-pole



4	Switching output (SO)
3	Ground (GND)
2	Output signal (0... 10 V / 4... 20 mA)
1	Supply voltage (18... 30 VAC / VDC)



Jumper assignments

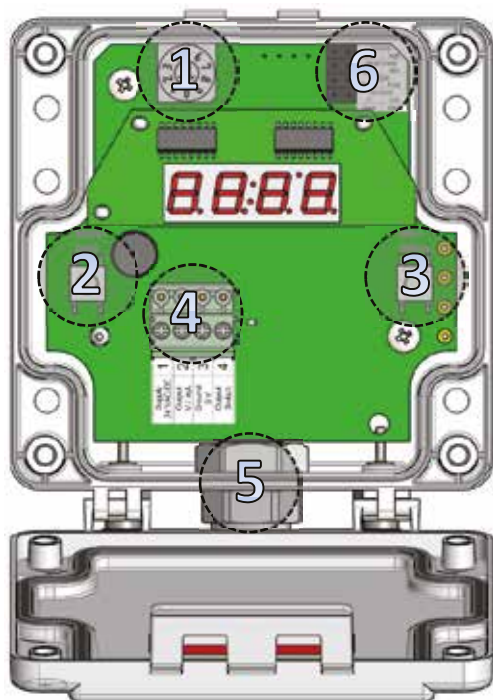

1. Rotary coding switch
2. Button MODE/Offset
3. Button SET/Switch
4. Plug-in terminals
5. Cap nut conduit
6. Jumper

Jumper assignments

The function settings of differential pressure transducer are achieved by inserting jumpers appropriately within the transducer.

Volume flow mode: Jumper 3 open



Function	Switched <input checked="" type="checkbox"/>	Open <input type="checkbox"/>
Entry	ref. Volume flow	K-factor
Response time	Slow	Fast
Operation mode		Volume flow
Output signal	0...10 V DC	4...20 mA

Volume flow mode: Jumper 3 plugged in

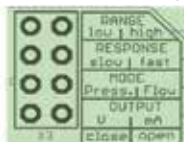

Function	Switched <input checked="" type="checkbox"/>	Open <input type="checkbox"/>
Setting	Zero-point	Analog end point
Response time	Slow	Fast
Operation mode	Pressure	Volume flow
Output signal	0...10 V DC	4...20 mA

Dimensions (mm)

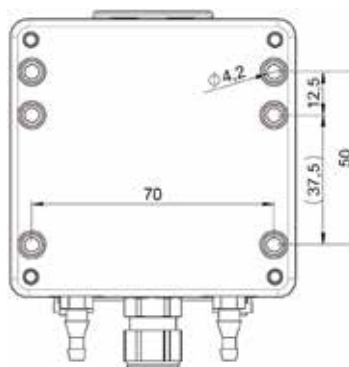
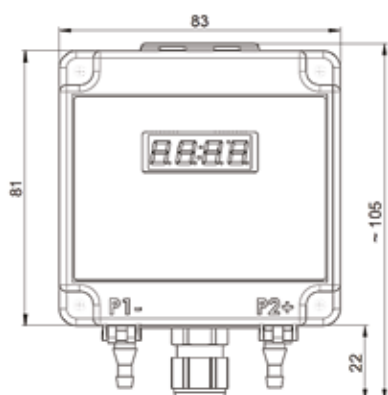
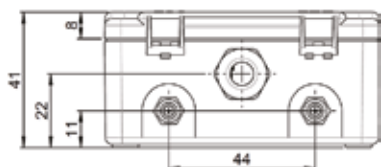



Description

The differential pressure transmitters serie PTQ is used to measure differential pressure, overpressure and vacuum of gaseous, non-aggressive media. It provides 8 pressure ranges and 2 output signals, which are easily selectable by jumper or rotary selector switch. Possible fields of application are building automation and air conditioning systems, overpressure measurement in clean rooms and laboratories, measurement of constant pressure in VAV applications, dynamic filter and ventilator monitoring.

Technical specifications

Medium	Air, non-combustible and non-aggressive gases
Measurement range	-50...0...+50 Pa, -100...0...+100 Pa, -250...0...+250 Pa, -500...0...500 Pa, 0...100 Pa, 0...250 Pa, 0...500 Pa, 0...1000 Pa
Linearity and hysteresis error	≤ ±1% of FS
Repetition accuracy	≤ ±0.2 % of FS
Response time	0.1 s or 1 s, selectable by jumper
Position dependence	≤ ±0,02% of FS/g
Long term stability	< ±0,5% final value/year
Offset calibration	It performs an automated zero offset compensation. No re-calibration needed.
Max pressure	20 kPa
Supply voltage	18...30 V AC / 16...32 V DC
Output signal	3-wire connection, with switching output. The factory setting is 0-10 V DC, but can be changed to 4-20 mA by removing the jumper.
Switching output	npn transistor output for max. 30 V DC/100 mA
Electrical connection	screw terminal block for wires and strands up to 1,5 mm ²
Display, optional	LED, 4 digits
Housing	Housing with process connection P2 (-) Base part with process connection P1 (+)
Cable conduit	M16x1,5 connection made of polyamide
Dimensions	approx. Ø 85 x 58 mm
Weight	approx. 150 g
Protection type	IP54
Working humidity	0...95% RH, non-condensing
Working temperature	0...+50°C
Storage temperature	-40...+70°C
Accessories	Connection set (PVC-hose 2 m Ø 6 with 2 ABS nippels and 4 screws) included and snap-on plastic brackets optionally
Installation	Screw fastening
Installation position	any
Standards	CE-conformity, RoHS



Models	Measuring range	Version
PTQ1	-50...0...+50 Pa, -100...0...+100 Pa, -250...0...+250 Pa, -500...0...500 Pa, 0...100 Pa, 0...250 Pa, 0...500 Pa, 0...1000 Pa	
PTQ1D	-50...0...+50 Pa, -100...0...+100 Pa, -250...0...+250 Pa, -500...0...500 Pa, 0...100 Pa, 0...250 Pa, 0...500 Pa, 0...1000 Pa	with display
Accessories:	APA1 Snap-on plastic bracket, L-shaped APA2 Snap-on plastic bracket, S-shaped	



Electrical wirings

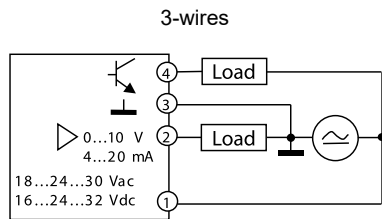

4	SA	Switching output, npn
3	G O	Ground G N D
2	Y	Output signal 0... 10V / 4... 20 mA
1	G	Supply voltage 24 VAC / VDC

Setting

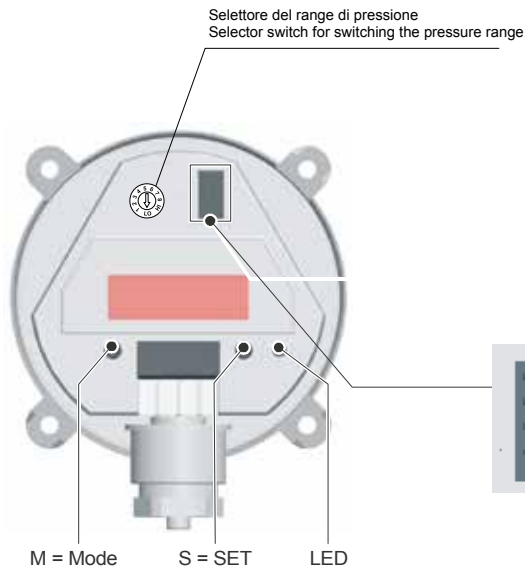

Selettore Selector	Scala Range
1	0...100 Pa
2	0...250 Pa
3	0...500 Pa
4	0...1000 Pa
5	-50...0...+50 Pa
6	-100...0...+100 Pa
7	-250...0...+250 Pa
8	-500...0...+500 Pa
0	Test output (0 V / 4 mA)
9	Test output (10 V / 20 mA)

	Jumper (switched)	Aperto (open)
Range pressione (Pressure range)	Bassa (low)	Alta (high)
Risposta (Response)	Lenta (slow)	Veloce (fast)
Funzionamento (Mode)	Lineare (linear)	Quadratico (square root)
Segnale di uscita (Output signal)	0...10 V	4...20 mA

Dimensions (mm)

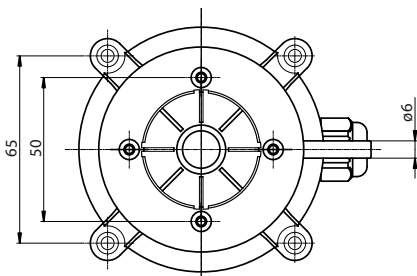

APA1 Snap-on plastic bracket, L-shaped

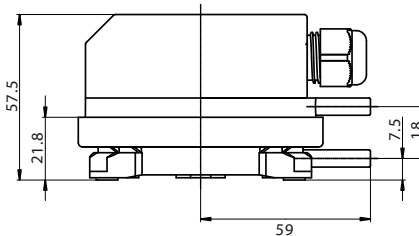

APA2 Snap-on plastic bracket, S-shaped

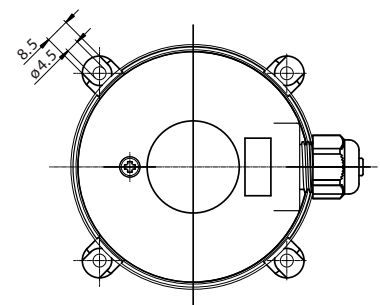

ABS nipple
(part of connection set APA3)

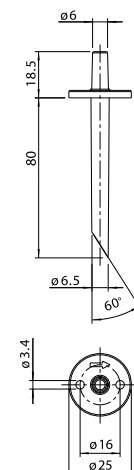
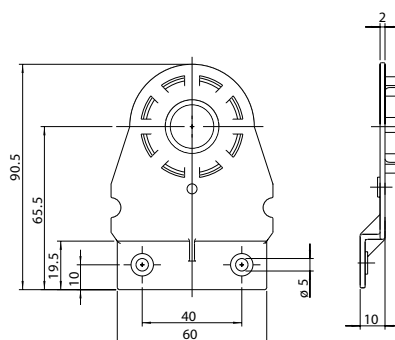
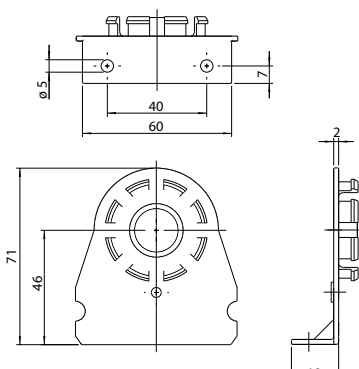



■ Programming version without display

In the version without display, you can program the switching value by acting in this way:

1 Apply the pressure or differential pressure at which you want the system switches

2 Press the „S“ button for 5 seconds until the LED flashes quickly.

At this point the switching value is saved and the LED will light while reaching the set pressure.

■ Programming display version

Pulsante / switch	Display	Passo / step	Note / Information
	250		Pressione rilevata / current measured value
Press >M<			
	OFF5		Calibrazione offset* / Offset calibration*
Press >M<		Press >S<	Visualizza attuale offset / Show actual offset value
	-3		
		Press >S<(5 sec)	Ritaratura offset / recalibration of offset
	0		
		Press >M<	Memorizzazione offset, il display lampeggia / Store offset, Display blinking for confirmation
	OFF5		
Press >M<			
	SP		Impostazione valore di commutazione / Setting switching level
		Press >S<	Visualizza attuale valore di commutazione / Show actual switching level
	112		
		Press >S<(5 sec)	Modifica valore di commutazione / Modify switching level
	112		
		Press >M<	Memorizzazione valore di commutazione, il display lampeggia / Store switching level, Display blinking for confirmation
	SP		
Press >M<			
	HI		Valore di picco max. / peak value high
		Press >S<	Visualizza il valore di picco max. / show peak value high
	240		
		Press >M<	Ritorno / return
	HI		
Press >M<			
	LO		Valore di picco min. / peak value low
		Press >S<	Visualizza il valore di picco min. / show peak value low
	-50		
		Press >M<	Ritorno / return
	LO		
Press >M<			
	250		Pressione rilevata / current measured value

* Free from pipes or remove the cap from the two nozzles before proceeding with the offset re-calibration.



Description

The air velocity transmitter series KFSE is design to control the air velocity into air duct in HVAC systems and in VAV applications.

Technical specifications

Measurement range velocity	20 m/s or 5 m/s
Accuracy air velocity	±5% for 20 m/s
Measurement range °C	-30...+70°C and 0...100°C
Accuracy °C	<1,0°C at min. 1 m/s
Power supply	24 VAC (±5%) 50-60 Hz / 15...35 VDC
Power consumption	< 2,5 W
Electrical connection	Screw terminals max. 1,5 mm ²
Housing	ABS
Dimensions	See drawing
Protection type	IP65 enclosure, IP10 probe
Working temperature °C	-25...+70°C
Storage temperature °C	-30...+85°C
Standards	CE conformity, RoHS EMC Directive EN 61326-1
Weight	265gr



Order matrix

Model	Max. range	Output 1 Air velocity		Output 2 Air velocity / temp.		Options	
KFSE	2 20 m/s 5 5 m/s	0	no output	0	no output	T	Temperature
		1	0...10 V	1	0...10 V	M	Modbus
		2	2...10 V	2	2...10 V	D	Display
		3	0...5 V	3	0...5 V	R	Relay 1x *
		4	1...5 V	4	1...5 V	RR	Relay 2x *
		5	4...20 mA	5	4...20 mA	B	Buzzer

1. AO1 is always for Air Velocity output.
2. AO2 is Air Velocity output as standard but it will be Temperature output, if option T choosed.
3. Temperature output option should be informed while ordering, it can not be changed after manufacturing.
4. For fine temperature measurements, air velocity should be higher than 2 m/s.

* Relay and buzzer options have to be ordered with the display option.

Response Time Setting

Please check if there is any special instruction on the enclosure or inside the cover.

DIP	Response Time
	5 sec
	1 sec



Range Settings

Please check if there is any special instruction on the enclosure or inside the cover.

DIP	KFSE.5 Ranges	DIP	KFSE.2 Ranges	DIP	Temp. Ranges
	0...5 m/s		0...20 m/s		-30 ...+70°C
	0...3 m/s		0...15 m/s		0 ...+100°C
	0...2 m/s		0...10 m/s		
	0...1 m/s		0...5 m/s		

Electrical Connections

1. Please be sure about current direction for current outputs and polarity for voltage outputs.
2. Relay contact is Normally Open and rating is max. 1A at 230VAC.
3. We kindly advise using 24V for avoiding high voltage harmonics and external power relay for bigger loads.
4. Please use shielded and twisted paired cables for Modbus connections.
5. Please observe RS485 termination rules, max. 32 devices in a single Modbus line.

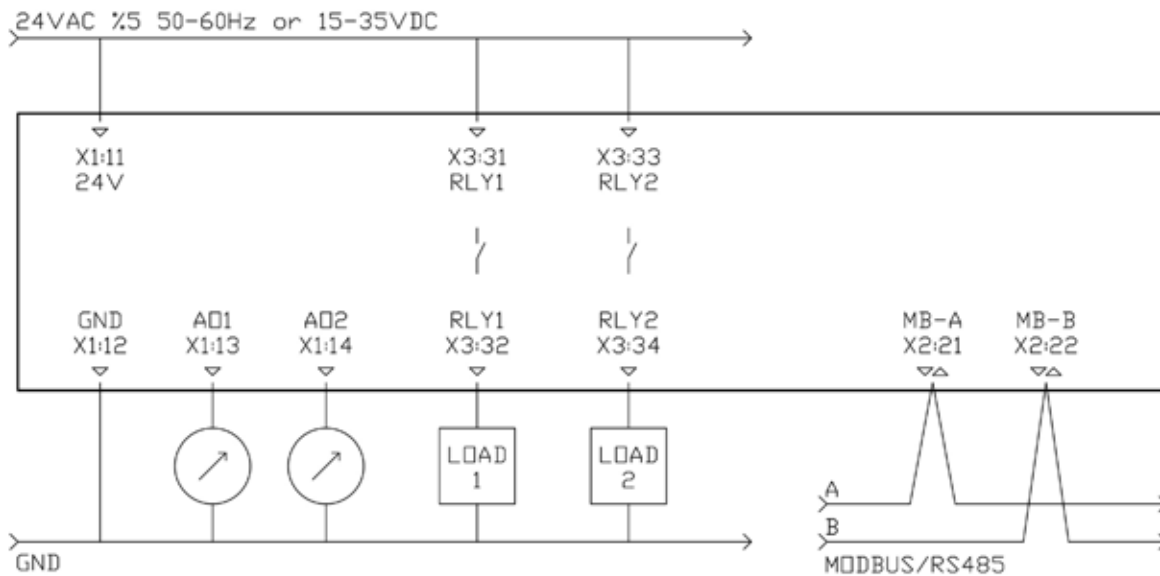



Transmitter hardware

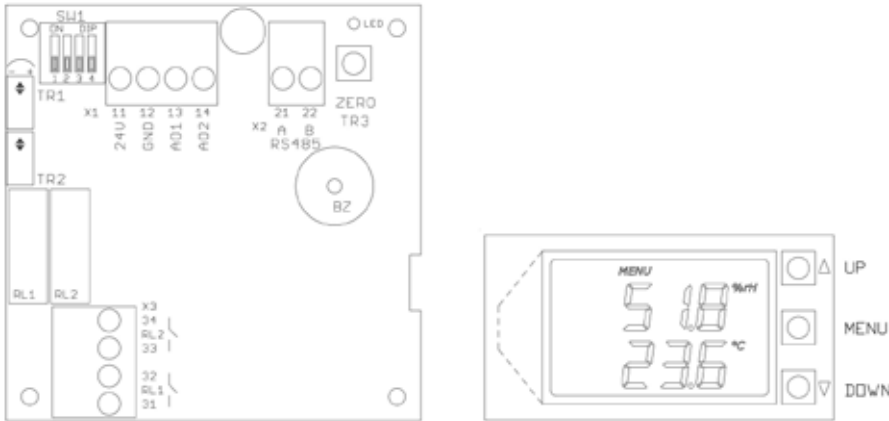

SW1	DIP Switch for configuration range and response time	
X1 TERMINAL		
11	24V	15...35 VDC or 24 VAC (\pm %5, 50-60 Hz)
12	GND	ground for power and reference for outputs
13	AO1	analog output 1
14	AO2	analog output 2
X2 TERMINAL		
21	A / RS485	modbus communication positive pair
22	B / RS485	modbus communication negative pair
LED	bead LED, periodically lights ON and OFF modbus communication, blinks when there is a communication	
TR1	not used	
TR2	offset trimmer for temperature	
ZERO / TR3	not used	
RL1 & RL2	relay 1 and relay 2	
BZ	buzzer	
X3 TERMINAL		
31-32	NO - RL1	relay 1 dry contact max. rating 1A @ 220 VAC
33-34	NO - RL2	relay 2 dry contact max. rating 1A @ 220 VAC

Display & Buttons

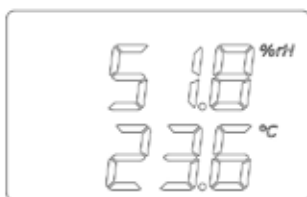
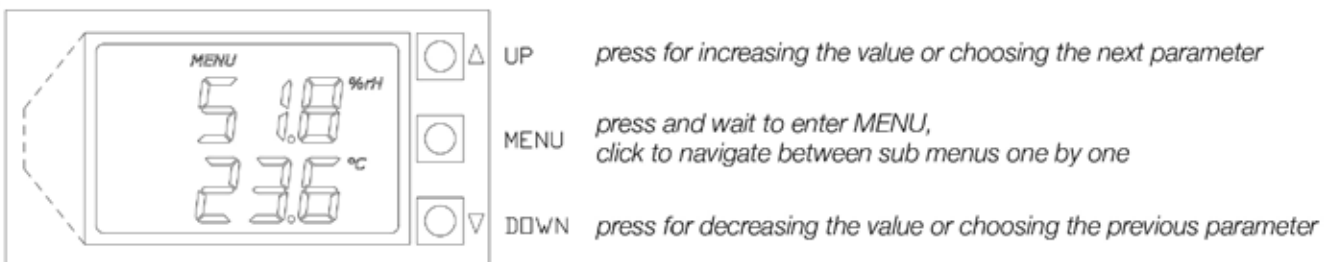

main screen
transmitter is working



keep pressing MENU button
transmitter is not working in MENU mode



Parameters for Relay & Buzzer

Main Screen >>>> r1 L > r1 H > r1 A > Main Screen

	LOW set point for Relay 1		LOW set point for Relay 2		LOW set point for Buzzer
	HIGH set point for Relay 1		HIGH set point for Relay 2		HIGH set point for Buzzer
	ACTION selection for Relay 1		ACTION selection for Relay 2		ACTION selection for Buzzer

Actions for Relay & Buzzer

- action 0, valid for relays and buzzer,
relay contact is always OPEN
buzzer is always SILENCE
- action 1, valid for relays and buzzer,
relay contact is CLOSED between points, OPEN under LOWpoint and OPEN over HIGHpoint
buzzer is WARNING between points, SILENCE under LOWpoint and SILENCE over HIGHpoint
- action 2, valid for relays and buzzer,
relay contact is OPEN between points, CLOSED under LOWpoint and OPEN over HIGHpoint
buzzer is SILENCE between points, WARNING under LOWpoint and SILENCE over HIGHpoint
- action 3, valid for relays and buzzer,
relay contact is CLOSED over HIGHpoint, OPEN under LOWpoint, hysteresis between points
buzzer is WARNING over HIGHpoint, SILENCE under LOWpoint, hysteresis between points
- action 4, valid for relays and buzzer,
relay contact is OPEN over HIGHpoint, CLOSED under LOWpoint, hysteresis between points
buzzer is SILENCE over HIGHpoint, WARNING under LOWpoint, hysteresis between points
- action 5, valid only for buzzer,
buzzer is WARNING over HIGHpoint, SILENCE under LOWpoint,
buzzer is WARNING intermittently between points,
- action 6, valid only for buzzer,
buzzer is WARNING under LOWpoint, SILENCE over HIGHpoint,
buzzer is WARNING intermittently between points,
- action 7, valid only for buzzer,
buzzer is following relay 1 contact,
buzzer is WARNING when relay 1 contact is CLOSED, SILENCE when the contact is OPEN
- action 8, valid only for buzzer,
buzzer is following relay 2 contact,
buzzer is WARNING when relay 2 contact is CLOSED, SILENCE when the contact is OPEN



ACTIONS	under LOW	between LOW & HIGH	over HIGH
0 : 0.0.0	Open / Silence	Open / Silence	Open / Silence
1 : 0.1.0	Open / Silence	Closed / Warning	Open / Silence
2 : 1.0.1	Closed / Warning	Open / Silence	Closed / Warning
3 : 0.X.1	Open / Silence	Hysteresis	Closed / Warning
4 : 1.X.0	Closed / Warning	Hysteresis	Open / Silence
5 : 0.-.1	Silence	Pre Alarm	Warning
6 : 1.-.0	Warning	Pre Alarm	Silence
7 : = r1	Silence when RL1 is Open, Warning when RL1 is Closed		
8 : = r2	Silence when RL2 is Open, Warning when RL2 is Closed		

0 : Relay Contact is OPEN, Buzzer is in Silent mode

1 : Relay Contact is CLOSED, Buzzer is in Warning mode

X : Relay Contact is at HYSTERESIS position, OPEN if previous position open, CLOSED if previous position closed

: Buzzer is in HYSTERESIS mode, Silent if previous mode is silent, Warning if previous mode is warning

- : Buzzer is in PRE ALARM mode, Buzzer is warning intermittently

Modbus RS485 protocol

Default Settings: Modbus ID:1, 9600, 8bit, None, 1. Register Table starts from Base 1.

Use Function 3 for Reading and Function 6 for Writing Holding Registers. Whenever writing to any Modbus Parameter, the new parameter is activated instantly and you should have to configure the master device according to new parameters. For every reboot/initializing, Modbus is activated with default parameters for 3 seconds. After 3 seconds, Modbus is reconfigured according to your parameter settings.

Unlisted registers are for analog output calibrations and some system parameters. Please do not change unlisted registers.

Register	R/W	Range	Description
1	R & W	1...254	Modbus Address
2	R & W	0...1	Baudrate, 0: 9.600, 1: 19.200
3	R & W	0...3	Bit_Parity_Stop, 0: 8bit_None_1, 1: 8bit_None_2, 2: 8bit_Even_1, 3: 8bit_Odd_1
4	R	0...2.000	AV as m/s x100, divide by 100 for exact value
5	R	-3.000...10.000	TEMP as C x100, divide by 100 for exact value
6	R	0 or 1	Relay 1, contact position, 0: OFF - Contact is Open, 1: ON - Contact is Closed
7	R	0...1.000	Relay 1, LOW point
8	R	0...1.000	Relay 1, HIGH point
9	R	0...4	Relay 1, ACTION
10	R	0 or 1	Relay 2, contact position, 0: OFF - Contact is Open, 1: ON - Contact is Closed
11	R	0...1.000	Relay 2, LOW point
12	R	0...1.000	Relay 2, HIGH point
13	R	0...4	Relay 2, ACTION
14	R	0 or 1	Buzzer, 0: OK-Silence, 1: PreAlarm - warning intermittently, 2: WARNING continuously
15	R	0...1.000	Buzzer, LOW point
16	R	0...1.000	Buzzer, HIGH point
17	R	0...4	Buzzer, ACTION



Register	R/W	Range	Description
18-28			set-up parameters, never use, never change..!
29	R	0...2.000	AV as m/s x100, divide by 100 for exact value
30	R	0...3.937	AV as feet/min
31	R	-3.000...10.000	TEMP as C x100, divide by 100 for exact value
32	R	-30...100	TEMP as C
33	R	-2.200...21.200	TEMP as F x100, divide by 100 for exact value
34	R	-22...212	TEMP as F

Air Velocity Calibration Procedure

Set-up for Calibration

1. Power the unit and connect the unit with Modbus/RS485,
2. Check response time, response time can be set 1 sec. or 5 sec., it is recommended to set 1 second for any calibration, check page 2 for response time setting,

ZERO Calibration

3. Close the probe with the original cap and keep the unit working,
4. Wait for about 10 minutes, for measuring the raw value of 0 m/s,
5. Read U0 value from MR_48, note this value to your records,
6. Write U0 value to MR_41,
7. Write 9 to MR_27, this is a must for saving the parameters, MR_27 value turns to 0 automatically,
8. Remove the cap and you are ready for span calibrations,

SPAN-1 Calibration, for low AV values

9. After ZERO please do not loose much time,
10. Apply air velocity as much as:
 - for KFSE.2 series, 5 m/s,
 - for KFSE.5 series, 1 m/s,
11. You do not need to wait too much, just be sure that you have a stable measurement,
12. Read U50-1 value from MR_48, note this value to your records,
13. Write U50-1 value to MR_42,
14. This calibration value is used for the sub-ranges for:
 - for KFSE.2 series, 5 and 10 m/s,
 - for KFSE.5 series, 1 and 2 m/s,
15. Write 9 to MR_27, this is a must for saving the parameters, MR_27 value turns to 0 automatically,

SPAN-2 Calibration, for high AV values

16. After SPAN-1 calibration, please do not loose much time,
17. Apply air velocity as much as:
 - for KFSE.2 series, 10 m/s,
 - for KFSE.5 series, 2,5 m/s,
18. You do not need to wait too much, just be sure that you have a stable measurement,
19. Read U50-2 value from MR_48, note this value to your records,
20. Write U50-2 value to MR_45,
21. This calibration value is used for the sub-ranges for:
 - for KFSE.2 series, 15 and 20 m/s,
 - for KFSE.5 series, 3 and 5 m/s,
22. Write 9 to MR_27, this is a must for saving the parameters, MR_27 value turns to 0 automatically,

Other Parameter Setting

23. Please calculate the values for = square root of (V50) X 1.000
24. Typical V50-1 values:
 - for KFSE.2 series: V50-1 for 5 m/s is 2.236, write it to MR_43,
 - for KFSE.5 series: V50-1 for 1 m/s is 1.000, write it to MR_43,
25. Typical V50-2 values:
 - for KFSE.2 series: V50-2 for 10 m/s V50 is 3.162, write it to MR_46,
 - for KFSE.5 series: V50-2 for 2,5 m/s is 1.581, write it to MR_46,
26. Write 9 to MR_27, this is a must for saving the parameters, MR_27 value turns to 0 automatically,
27. Calibration is done.

Notes:

28. Please do not un-power the unit while calibration,
29. Please use filtered clean air while applying air velocity,
30. Please re-power the unit and check the parameters that you set,



Air Velocity Calibration Parameters

Register	R/W	Range	Description
27	R & W		Write 9 for saving calibration parameters
41	R	U ₀	Raw Value at 0 m/s
42	R & W	U ₅₀₋₁	Raw Value for the lower calibration point
43	R & W	V ₅₀₋₁	Air Velocity for the lower calibration point
44	R	k _{av-1}	K constant for the lower calibration point, calculated automatically
45	R & W	U ₅₀₋₂	Raw Value for the higher calibration point
46	R & W	V ₅₀₋₂	Air Velocity for the higher calibration point
47	R	k _{av-2}	K constant for the higher calibration point, calculated automatically
48	R	U _x	Raw Value of the sensing element
49	R	AV	Air Velocity x1.000, divide 1.000 for actual value, in m/sec.
50	R		blank

Temperature Calibration

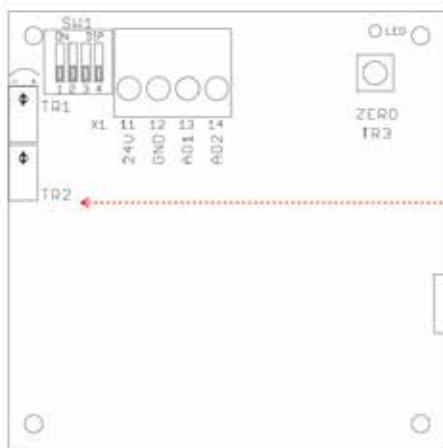

TR2, offset for Temperature

OFFSET for Temperature

1. Apply air flow min. 1 m/sec
2. Adjust the TR2 trimmer while reading analog out or display

Dimensions (mm)

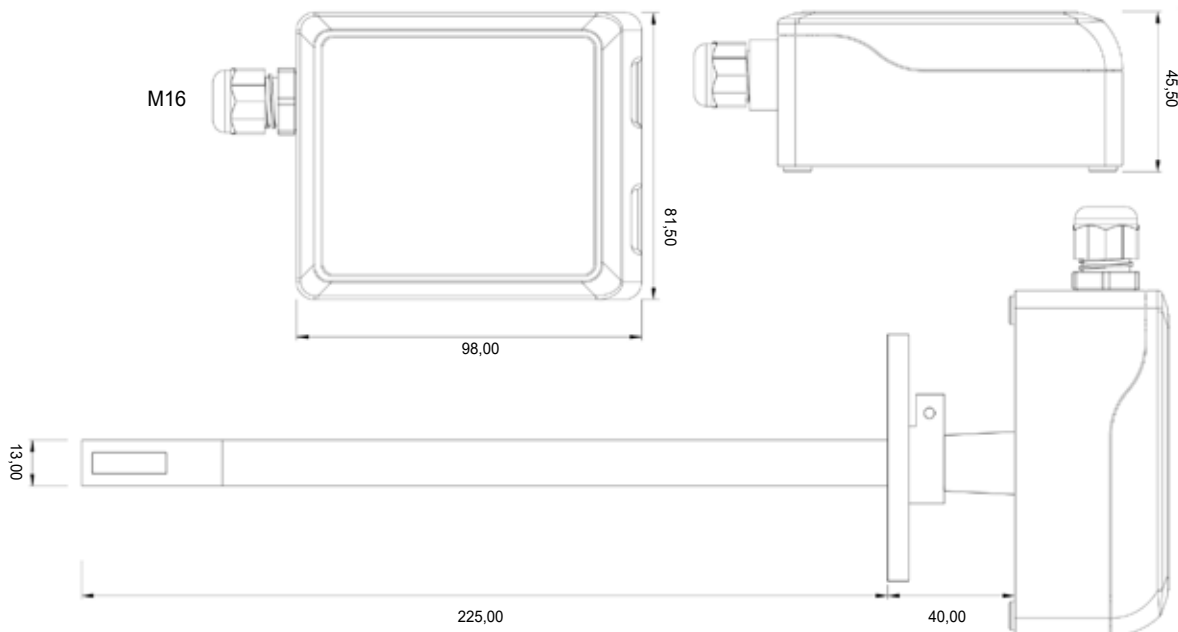



Description

The KSWL probe detects and reports the presence of water leaks or high condensation levels via dedicated sensor cables.

Technical specifications

Power supply	24 V AC (±5%), 50-60 Hz, 15...35 V DC
Consumption	< 2 W
Relay	SPTD dry contact, potential-free
Contact rating	max 1 A a 230 V AC
Buzzer	> 90 db
Sensitivity	adjusted by DIP Switch as HIGH or LOW
Response time	5-10 sec, depending on moisture level
Electrical connection	Screw terminal, max. 1,5 mm ²
Cable gland	M16
Weight	125 g
IP rating	IP54
Standards	CE conformity, RoHS, EN 61326-1



Order matrix

Model	Input	Option
KSWL	10 1x cable	M Modbus
	31 3x cable + external contact	R Relay B Buzzer P Probe
KSWL1M	detector cable, length 1 m	
KWSL25M	detector cable, 1 cable roll, 25 m	
KWSL50M	detector cable, 1 cable roll, 50 m	

DIP Switch

SW1 - Sensitivity

	ON	HIGH, responds to lower level of moisture
	OFF	LOW, responds to higher level of moisture

SW2 - Alarm mode

	ON	PERMANENT Alarm, until a manual reset
	OFF	TEMPORARY Alarm, resets automatically whenever alarm is off

SW3 - Buzzer mode

	ON	Intermittent (pulsed) signal
	OFF	Continuous signal

SW4 - Relay reverse

	ON	Reversed, relay is normally closed and de-activates with alarm
	OFF	Normal, relay is normally open and activates with alarm



Transmitter hardware

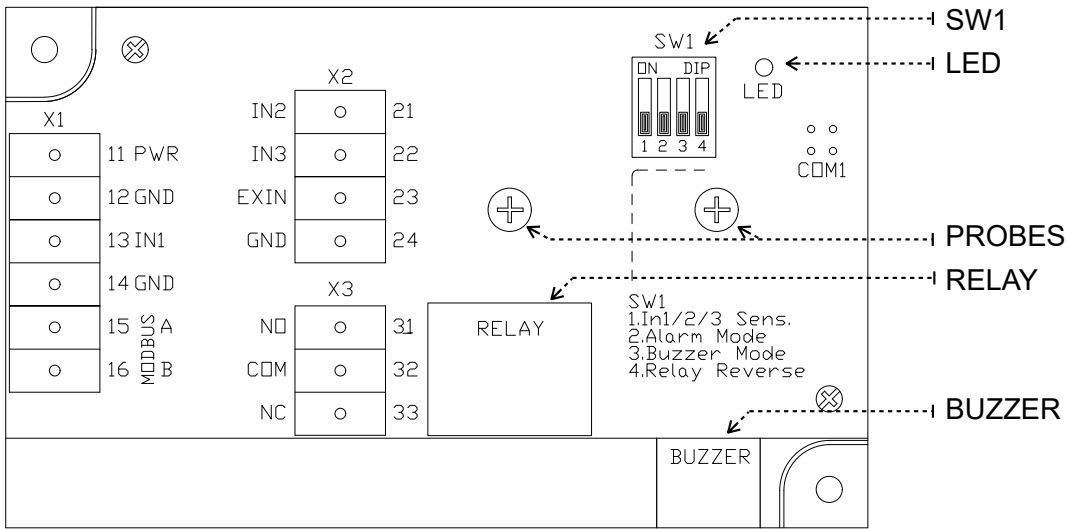

SW1	config	see DIP switch
LED	working modbus alarm	blinks periodically blinks for each Modbus transmitting on when buzzer signals
PROBES		adjustable probes
RELAY		max. rating 1A @ 220 Vac
BUZZER	silent alarm	normal working sounds continuous or intermittent
X1	11 PWR 12 GND 13 IN1 14 GND 15 modbus-A 16 modbus-B	14...35 Vdc or 24 Vac (\pm %5, 50-60 Hz) ground for power and reference for outputs detector cable input 1 reference for IN1 modbus communication positive pair modbus communication negative pair
X2	21 IN2 22 IN3 23 EXIN 24 GND	detector cable input 2 detector cable input 3 external input, only dry contact reference for IN2, IN3 and EXIN
X3	31 32 33	normally open common normally closed

Electrical wirings

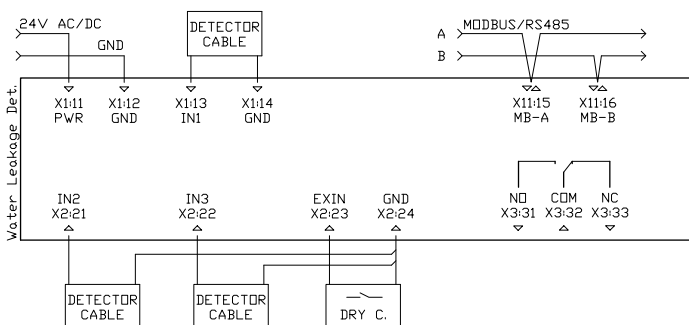

Relay contact rating is max. 1A at 230 VAC.
We kindly advise using 24V on relay contacts and using external power relay for bigger loads to avoid high voltage harmonics.
Please use shielded and twisted paired cables for modbus connections.



Modbus Configuration

Default Settings: Modbus ID:1, 9600, 8bit, None, 1. Register Table starts from Base 1.

Use Function 3 for Reading and Function 6 for Writing Holding Registers. Whenever changing any Modbus Parameter, the new parameter is activated instantly and you should have to configure the master device according to the new parameters.

ID:254 is the common address for all units.

Register	R/W	Default	Range	Description
1	R & W	1	1...253	Modbus Address
2	R & W	0	0 or 1	Baudrate, 0: 9.600, 1: 19.200
3	R & W	0	0...3	Bit_Parity_Stop, 0: 8bit_None_1, 1: 8bit_None_2, 2: 8bit_Even_1, 3: 8bit_Odd_1
4	R & W	500	0...1023	Threshold for HIGH sensitivity, lower values for higher sensitivity
5	R & W	1000	0...1023	Threshold for LOW sensitivity, higher values for lower sensitivity
6	R	0	0...1023	IN1, Analog value
7	R	0	0...1023	IN2, Analog value
8	R	0	0...1023	IN3, Analog value
9	R	0	0 or 1	IN1, Alarm situation, 0: normal, 1: alarm
10	R	0	0 or 1	IN2, Alarm situation, 0: normal, 1: alarm
11	R	0	0 or 1	IN3, Alarm situation, 0: normal, 1: alarm
12	R	0	0 or 1	EXIN, Alarm situation, 0: normal, 1: alarm
13	R	0	0 or 1	TOTAL ALARM, any alarm will be enough for total alarm, 0: normal, 1: alarm
14	R	0	0	Empty, for future use
15	R	0	0	Empty, for future use

Dimensions (mm)

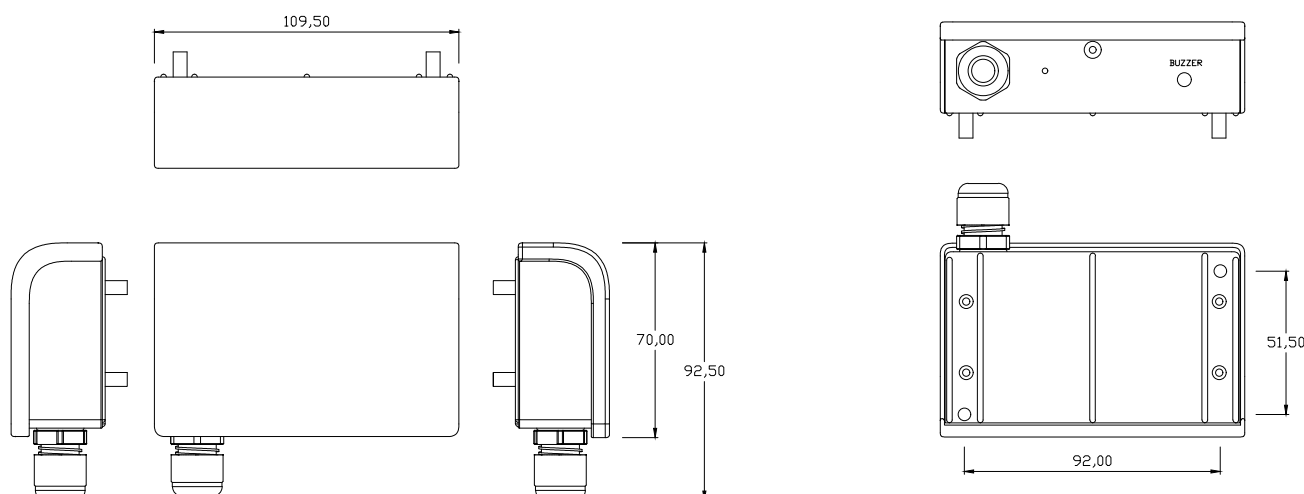



cyanline

sensors

Description

The temperature sensor serie SC measures the temperature from -35 up to +105°C of gaseous and liquid media. The range is available with all type of current sensor elements. The stainless steel sleeve protects the sensor e.g. against mechanical impacts. It is sealed by the PVC cable against humidity and can be mounted in an immersion pocket, with a spring or bracket for pipe contact.

Technical specifications

Measurement range	-35...+105°C
Sensor	Pt100, Pt1000, Ni1000, KTY, NTC
Type of connection	2-wires
Measured current	approx. 1 mA
Electrical connection	PVC cable from 2 m up to 5 m (2 x 0,25 mm ² , max. +105°C) with core cable ends
Leakage resistance	> 100 MOhm, at +20°C (500 V DC)
Protection sleeve	Stainless steel V4A
Sleeve dimension	Ø 6x50 mm
Protection type	IP67 (moisture sealed rolled)
Storage temperature	-20...+70°C
Installation	screw-in pocket, mounting flange, compression fitting (not in scope of delivery)
Standards	CE conformity, RoHS



Models	Type of sensor	Cable length (L)
SC1-1	Pt100 (DIN EN 60751 Cl. B)	1 m PVC (2x0,25 mm ²)
SC1-2	Pt100 (DIN EN 60751 Cl. B)	2 m PVC (2x0,25 mm ²)
SC1-5	Pt100 (DIN EN 60751 Cl. B)	5 m PVC (2x0,25 mm ²)
SC2-1	Pt1000 (DIN EN 60751 Cl. B)	1 m PVC (2x0,25 mm ²)
SC2-2	Pt1000 (DIN EN 60751 Cl. B)	2 m PVC (2x0,25 mm ²)
SC2-5	Pt1000 (DIN EN 60751 Cl. B)	5 m PVC (2x0,25 mm ²)
SC3-2	Ni1000 (TK6180)	2 m PVC (2x0,25 mm ²)
SC3-5	Ni1000 (TK6180)	5 m PVC (2x0,25 mm ²)
SC4-2	Ni1000 (TK5000)	2 m PVC (2x0,25 mm ²)
SC4-5	Ni1000 (TK5000)	5 m PVC (2x0,25 mm ²)
SC5-2	NTC20k (±1%)	2 m PVC (2x0,25 mm ²)
SC5-5	NTC20k (±1%)	5 m PVC (2x0,25 mm ²)
SC6-2	NTC10k (±1%) BETA 3435K	2 m PVC (2x0,25 mm ²)
SC6-5	NTC10k (±1%) BETA 3435K	5 m PVC (2x0,25 mm ²)
SC7-2	KTY 81-110 (±1%)	2 m PVC (2x0,25 mm ²)
SC7-5	KTY 81-110 (±1%)	5 m PVC (2x0,25 mm ²)
SC8-2	KTY 81-121 (±1%)	2 m PVC (2x0,25 mm ²)
SC8-5	KTY 81-121 (±1%)	5 m PVC (2x0,25 mm ²)

Dimensions (mm)

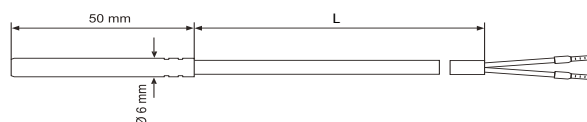



Strap-on temperature sensor

Description

The temperature sensor serie SCT measures the temperature from -50 up to +100°C strap-on mounting on pipes and arched surfaces. The range is available with all type of current sensor elements.

Technical specifications

Measurement range	-50...+100°C
Sensor	Pt100, Pt1000, Ni1000, NTC
Type of connection	2-wires
Measured current	approx. 1 mA
Electrical connection	2 m PVC cable (2 x 0,25 mm ² , max. +100°C) with core cable ends
Leakage resistance	> 100 MOhm, at +20°C (500 V DC)
Protection sleeve	Brass
Protection type	IP54
Storage temperature	-20...+70°C
Accessory	Spring band (included) for pipes from 25 to 110 mm
Standards	CE conformity, RoHS



Models	Type of sensor
SCT1-2	Pt100 (DIN EN 60751 Cl. B)
SCT2-2	Pt1000 (DIN EN 60751 Cl. B)
SCT3-2	Ni1000 (TK6180)
SCT4-2	Ni1000 (TK5000)
SCT5-2	NTC20k (±1%)
SCT6-2	NTC10k (±1%) BETA 3435K

Dimensions (mm)

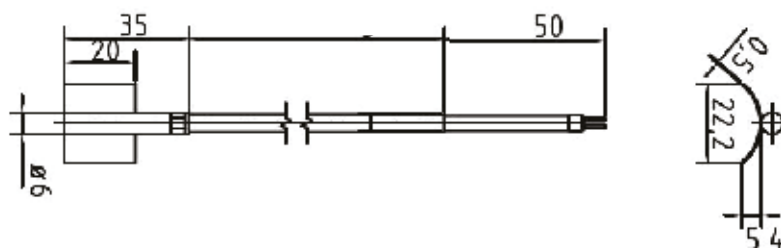



Description

The temperature sensor serie SCK measures the temperature from -50 up to +100°C on pipes or round surfaces. The range is available with all type of current sensor elements.

Technical specifications

Measurement range	-50...+100°C
Sensor	Pt100, Pt1000, Ni1000, NTC, KTY.
Type of connection	2 fili
Measured current	approx. 1 mA
Electrical connection	Screw terminal block for wires up to 1,5 mm ²
Housing	PA6, RAL9010
Cable entry	M16 high-strength cable gland with strain relief
Protection type	IP65
Storage temperature	-20...+70°C
Installation	Mounting flange (included)
Standards	CE conformity, RoHS



Models	Type of sensor
SCK1	Pt100 (DIN EN 60751 Cl. B)
SCK2	Pt1000 (DIN EN 60751 Cl. B)
SCK3	Ni1000 (TK6180)
SCK4	Ni1000 (TK5000)
SCK5	NTC20k (±1%)
SCK6	NTC10k (±1%) BETA 3435K
SCK7	KTY 81-110 (±1%)
SCK8	KTY 81-121 (±1%)

Dimensions (mm)

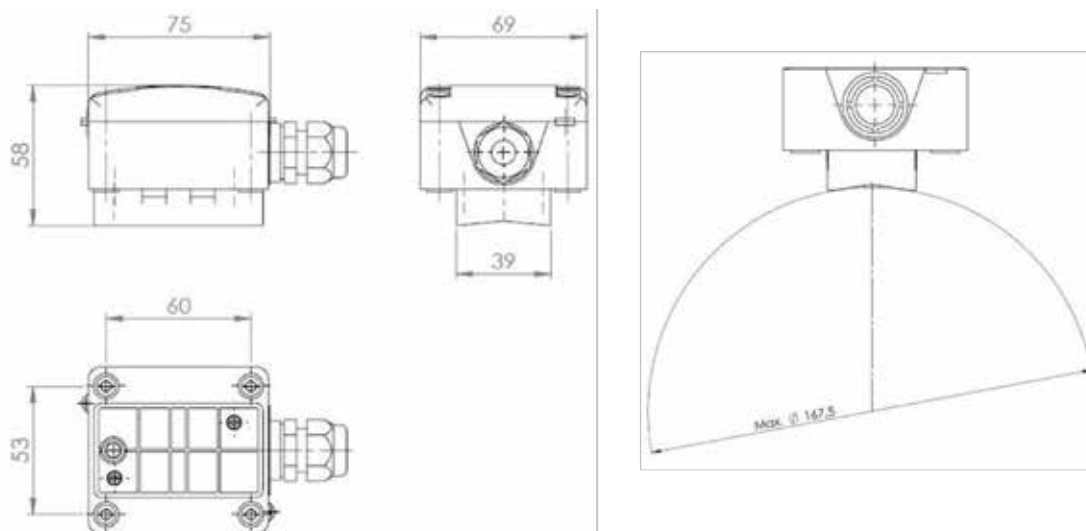

Description



The radiation sensor serie STR designed in a modern housing measures the temperature from -30 up to +75°C of gaseous media. The range is available with all type of current sensor elements and can be mounted directly on-wall with 2 fixing screws.

Technical specifications

Measurement range	-30...+75°C
Sensor	Pt100, Pt1000, Ni1000, KTY, NTC
Type of connection	2-wires
Measured current	approx.1 mA
Electrical connection	Screw terminal block for wires up to 1,5 mm ²
Cable entry	M16 high-strength cable gland with strain relief
Leakage resistance	> 100 MOhm, at +20°C (500 V DC)
Housing	polyamide (synthetic) colour white
Dimensions	58x64x53 mm
Protection type	IP65
Storage temperature	-20...+70°C
Installation	Screw fastening
Standards	CE-conformity, RoHS



Models	Type of sensor
STR1	Pt100 (DIN EN 60751 Cl. B)
STR2	Pt1000 (DIN EN 60751 Cl. B)
STR3	Ni1000 (TK6180)
STR4	NTC1,8k (±1%)
STR5	NTC20k (±1%)
STR6	NTC10k (±1%) BETA 3435K
STR7	KTY 81-110 (±1%)
STR8	KTY 81-121 (±1%)

Electrical wirings

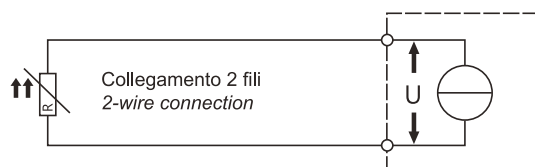

Dimensions (mm)

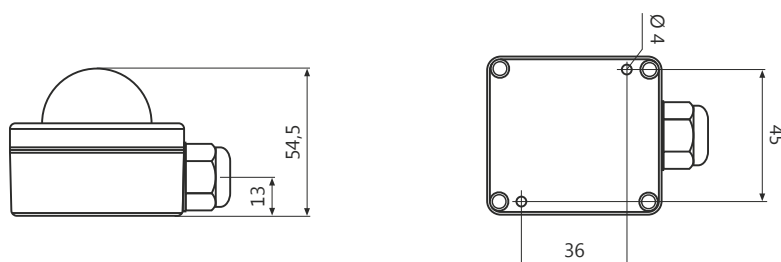

Description



The temperature sensor serie SA designed in a modern housing measures the temperature from -30 up to +60°C of gaseous media. The range is available with all type of current sensor elements and can be mounted directly on-wall by an adapter or 2 fixing screws. The extra wide ventilation slots ensures a good air circulation for a high accuracy of measurement.

Technical specifications

Measurement range	-30...+60°C
Sensor	Pt100, Pt1000, Ni1000, KTY, NTC
Type of connection	2-wires
Measured current	approx.1 mA
Electrical connection	Screw terminal block for wires up to 1,5 mm ²
Leakage resistance	> 100 MOhm, at +20°C (500 V DC)
Housing	polyamide (synthetic) colour white
Dimensions	87x87x30 mm
Protection type	IP30
Protection class	III
Storage temperature	-20...+70°C
Installation	Screw fastening on-wall, on in-wall junction box with optional adapter frame (optional)
Standards	CE-conformity, RoHS



Models	Type of sensor
SA1	Pt100 (DIN EN 60751 Cl. B)
SA2	Pt1000 (DIN EN 60751 Cl. B)
SA3	Ni1000 (TK6180)
SA4	Ni1000 (TK5000)
SA5	NTC20k (±1%)
SA6	NTC10k (±1%) BETA 3435K
SA7	KTY 81-110 (±1%)
SA8	KTY 81-121 (±1%)

Electrical wirings



Dimensions (mm)

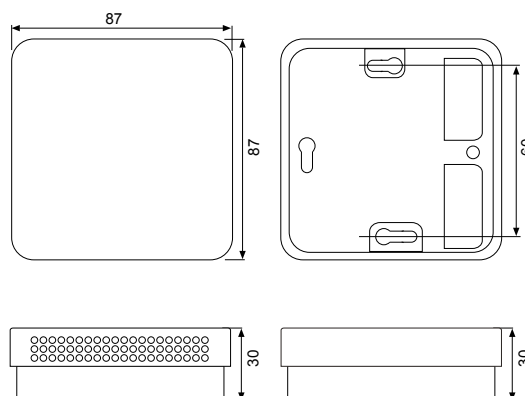



Description

The temperature sensor serie SO measures the outdoor temperature from -50 up to 90°C by a sensor built-in a robust plastic housing and is humidity and temperature resistant. The range is available with all type of current sensor elements. The temperature sensor can be mounted in climate-sensitive areas e.g. on outside walls by avoiding a direct solar radiation.

Technical specifications

Measurement range	-50...+90°C
Sensor	Pt100, Pt1000, Ni1000, KTY, NTC
Type of connection	2-wires
Measured current	approx. 1 mA
Electrical connection	Screw terminal block for wires up to 1,5 mm ²
Leakage resistance	> 100 MOhm, at +20°C (500 V DC)
Housing	Polyamide (synthetic) with snap closing screws, colour white like RAL 9010
Cable entry	M16 high-strength cable gland with strain relief
Dimensions	64x58x34,5 mm
Protection type	IP65
Storage temperature	-20...+70°C
Installation	Screw fastening
Standards	CE conformity, RoHS



Models	Type of sensor
SO1	Pt100 (DIN EN 60751 Cl. B)
SO2	Pt1000 (DIN EN 60751 Cl. B)
SO3	Ni1000 (TK6180)
SO4	Ni1000 (TK5000)
SO5	NTC20k (±1%)
SO6	NTC10k (±1%) BETA 3435K
SO7	KTY 81-110 (±1%)
SO8	KTY 81-121 (±1%)

Electrical wirings

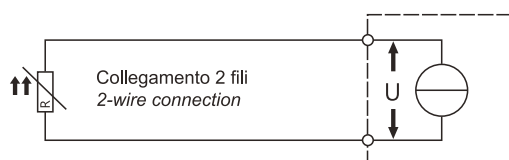

Dimensions (mm)

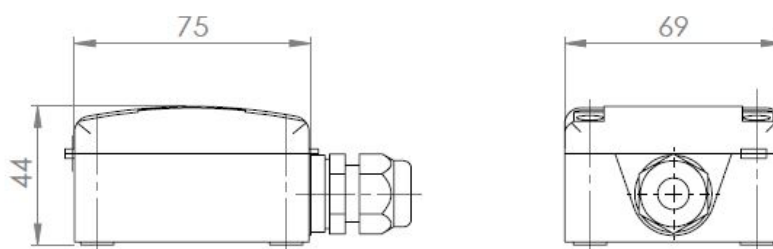



■ **Description**

The temperature sensor serie SZ measures the temperature from -30 up to +90°C of gaseous and liquid media. The range is available with all type of current sensor elements. Pockets or flange are available and can be installed directly into tanks, pipes or air ducts and can be easily and quickly be replaced in case of maintenance.

■ **Technical specifications**

Measurement range	-30...+150°C
Sensor	Pt100, Pt1000, Ni1000, NTC
Type of connection	2-wires
Measured current	approx. 1 mA
Electrical connection	Screw terminal block for wires up to 1,5 mm ²
Leakage resistance	> 100 MOhm, at +20°C (500 V DC)
Housing	Polyamide (synthetic) with snap closing screws, RAL 9010
Cable entry	M16 high-strength cable gland with strain relief
Installation length	from 100 to 400 mm
Material	Protection tube: stainless steel V4A
Protection type	IP65
Storage temperature	-20...+70°C
Installation	Pockets CuZn / stainless steel V4A, series PZ, or plastic flange, FZ1 (see next page)
Standards	CE conformity, RoHS



Models	Type of sensor	Tube length (L)
SZ1-100	Pt100 (DIN EN 60751 Cl. B)	100 mm
SZ1-150	Pt100 (DIN EN 60751 Cl. B)	150 mm
SZ1-200	Pt100 (DIN EN 60751 Cl. B)	200 mm
SZ1-400	Pt100 (DIN EN 60751 Cl. B)	400 mm
SZ2-100	Pt1000 (DIN EN 60751 Cl. B)	100 mm
SZ2-150	Pt1000 (DIN EN 60751 Cl. B)	150 mm
SZ2-200	Pt1000 (DIN EN 60751 Cl. B)	200 mm
SZ2-400	Pt1000 (DIN EN 60751 Cl. B)	400 mm
SZ3-100	Ni1000 (TK6180)	100 mm
SZ3-150	Ni1000 (TK6180)	150 mm
SZ3-200	Ni1000 (TK6180)	200 mm
SZ3-400	Ni1000 (TK6180)	400 mm
SZ4-100	Ni1000 (TK5000)	100 mm
SZ4-150	Ni1000 (TK5000)	150 mm
SZ4-200	Ni1000 (TK5000)	200 mm
SZ4-400	Ni1000 (TK5000)	400 mm
SZ5-100	NTC20k (±1%)	100 mm
SZ5-150	NTC20k (±1%)	150 mm
SZ5-200	NTC20k (±1%)	200 mm
SZ5-400	NTC20k (±1%)	400 mm



Models	Type of sensor	Tube length (L)
SZ6-100	NTC10k ($\pm 1\%$) BETA 3435K	100 mm
SZ6-150	NTC10k ($\pm 1\%$) BETA 3435K	150 mm
SZ6-200	NTC10k ($\pm 1\%$) BETA 3435K	200 mm
SZ6-400	NTC10k ($\pm 1\%$) BETA 3435K	400 mm

Electrical wirings

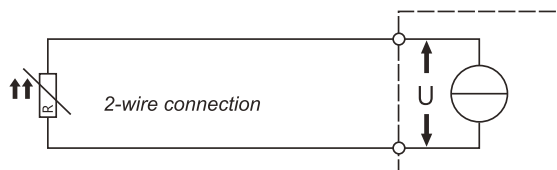

Dimensions (mm)

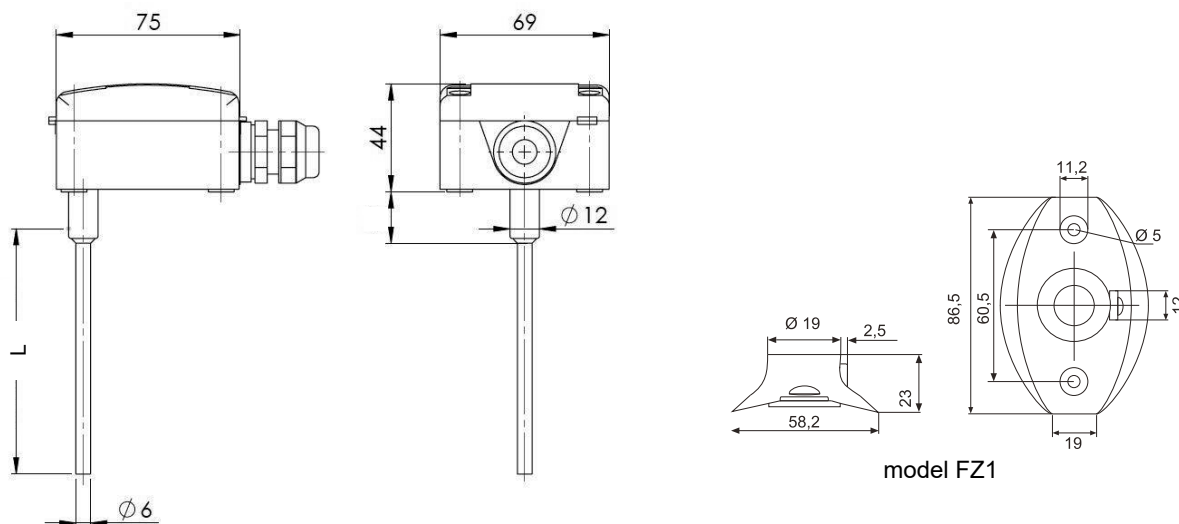

Pocket OT Ni	Length (L)	Tmax	Max static pressure
PZ100	100 mm	160°C	16 bar
PZ150	150 mm	160°C	16 bar
PZ200	200 mm	160°C	16 bar
PZ400	400 mm	160°C	16 bar

Pocket SS 316Ti	Length (L)	Tmax	Max static pressure
PZ100X	100 mm	400°C	40 bar
PZ150X	150 mm	400°C	40 bar
PZ200X	200 mm	400°C	40 bar
PZ400X	400 mm	400°C	40 bar

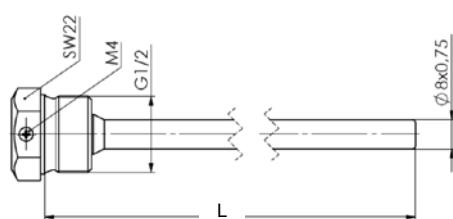

Serie PZ

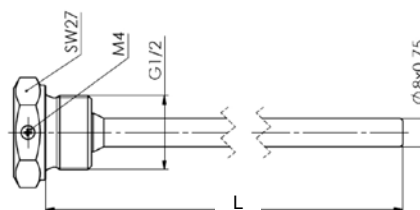

Serie PZ...X



Description

The room control unit SM has a temperature sensor for the remote measurement in domestic environments, offices, reception etc. and a setpoint control that limits the setting range to a predetermined value by the controller. It is available with occupancy button, LED and switch for fan speed.

Technical specifications

Sensor	NTC 10 kOhm
Power supply	24 V AC/DC
Potentiometer	5 kOhm
Occupancy button	10mA, 35 V DC
Fan speed	5 selectable with slide switch
Electrical connection	screw terminals max. 1,5 mm ²
Housing	ABS, colour white RAL 9010
Dimensions	87,5 x 87,5 x 30 mm
Weight	82 g
Protection type	IP20
Working temperature	0...+50°C
Storage temperature	-30...+60°C
Standards	CE-conformity, RoHS



Model	Occupancy button	Green LED	Speed switch
SM5			
SM5T	•		
SM5TL	•	•	
SM5TLS	•	•	•



■ Electrical wirings

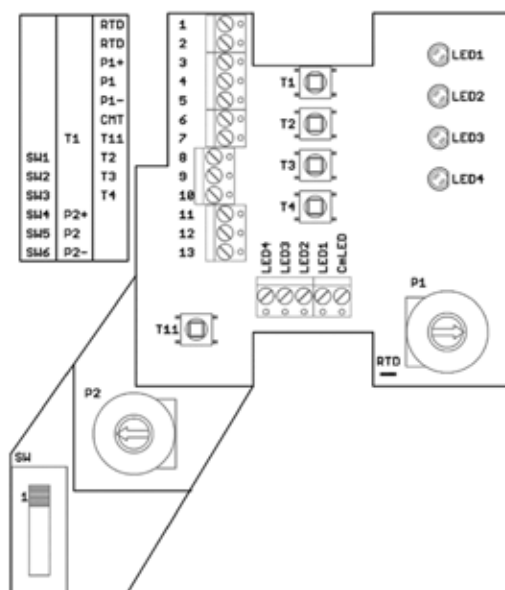

■ Dimensions (mm)

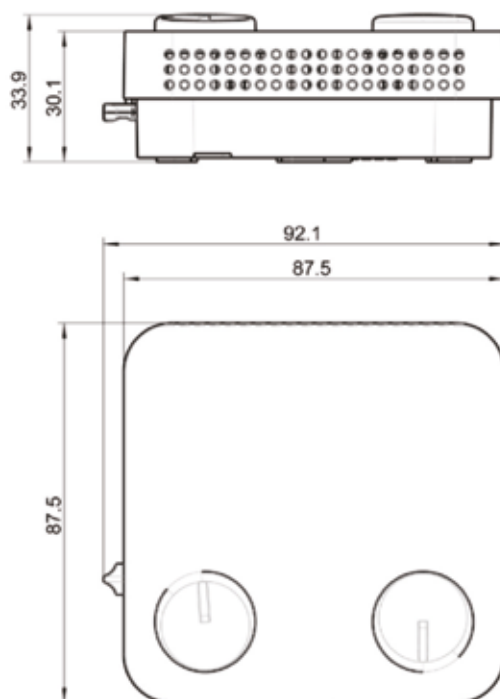

Resistance characteristics of temperature sensors

Temp. °C	PT100 Ohm	PT1000 Ohm	Ni1000 TK6180 Ohm	Ni1000 TK5000 Ohm	NTC 10K Ohm BETA 3435K K Ohm	NTC 20K Ohm K Ohm	KTY81-110 Ohm	KTY81-121 Ohm
-50,00	80,31	803,10	743	791	330,92	1667,57	515,00	510,00
-40,00	84,27	842,70	791	831	189,67	813,44	567,00	562,00
-30,00	88,22	882,20	842	872	112,06	415,48	624,00	617,00
-20,00	92,16	921,60	893	914	68,16	221,30	684,00	677,00
-10,00	96,09	960,90	946	956	42,62	122,47	747,00	740,00
0,00	100,00	1000,00	1000	1000	27,35	70,20	815,00	807,00
10,00	103,90	1039,00	1056	1045	17,98	41,56	886,00	877,00
20,00	107,79	1077,90	1112	1091	12,09	25,35	961,00	951,00
25,00	109,74	1097,40	1141	1114	10,00	20,00	1000,00	990,00
30,00	111,67	1116,70	1171	1138	8,31	15,89	1040,00	1029,00
40,00	115,54	1155,40	1230	1186	5,82	10,21	1122,00	1111,00
50,00	119,40	1194,00	1291	1235	4,15	6,72	1209,00	1196,00
60,00	123,24	1232,40	1353	1285	3,01	4,52	1299,00	1286,00
70,00	127,07	1270,00	1417	1337	2,22	3,10	1392,00	1378,00
80,00	130,89	1308,90	1483	1390	1,66	2,12	1490,00	1475,00
90,00	134,70	1347,00	1549	1444	1,26	1,54	1591,00	1575,00
100,00	138,50	1385,00	1618	1500	0,97	1,12	1696,00	1679,00
110,00	142,29	1422,00	1688	1557	0,76	0,82	1805,00	1786,00
120,00	146,06	1460,60	1760	1615	0,59	0,61	1915,00	1896,00
130,00	149,82	1498,20	1883	1675		0,46	2023,00	2003,00
140,00	153,58	1535,80	1909	1737		0,35	2124,00	2103,00
150,00	157,31	1573,10	1987	1799		0,27	2211,00	2189,00



general sales conditions

PRICES

The prices mentioned in our current price list are in Euro (€) do not include VAT and, even if confirmed, can be subject to variations due to increases in raw materials and labour costs. If the price is tied to parity between the Euro and a foreign currency, the rate of exchange value is specified by publication by the Banca d'Italia, as indicated in the „Il Sole 24 Ore“ daily newspaper. If the rate of exchange varies by more than 5%, we reserve the right to modify at any time our prices and the discounts applied to current orders. In such a case the buyer is entitled to withdraw immediately from the order.

The said prices do not include transport and insurance costs, import license expenses, customs charges, etc., and are considered chargeable to the Buyer.

Our quotations are not binding for the order; the Buyer accepts our delivery terms. After issuing our order acknowledgement, the order is confirmed.

Minimum ordering amount: € 250,00 net (under this amount the price in force is not confirmed). Neutral products are supplied without a surcharge but minimum 50 pieces/part number.

Certificates of origin issued by Chamber of Commerce € 50,00. Certificates legalized by foreign embassy min. € 250,00.

PACKING

Packing is included in the sale price. Packing different from standard will be invoiced at cost (standard plastic pallets at € 20,00 net each).

DOCUMENTS

We reserve rights on all documents referring to the products and/or made available with quotations, acknowledgements or on delivery. Such documents may neither be copied nor made available to third parties without our written agreement. They must be returned to us on request.

SHIPMENT

Shipment is ex our works, unless otherwise agreed.

As soon as the goods are handed over to the forwarder, all our obligations are considered fulfilled.

Therefore, all expenses and risks will be the Buyer's responsibility without any exceptions, even if the shipping charges are prepaid by us.

It is the Buyer's responsibility to insure the goods against damage and/or loss. We therefore cannot be held liable for damage and/or loss.

The shipping rates for Italy are at cost price, and we reserve the right to select the most suitable means of transport.

In case of payment by cash on delivery, the fees are always incurred by us and debited to the Buyer.

DELIVERY TERMS

Delivery terms are indicative and are not binding. We cannot be held liable for any production or shipment delay, if such a delay is caused by one of the following

reasons: a commercial blockade, difficulties in obtaining raw materials and/or other circumstances beyond our control. In that case we do not accept any penalties and the Buyer renounces any claims for indemnity and/or reimbursement of damages.

We reserve the right to delivery the goods before the agreed date.

CLAIMS

Claims have to be brought to our attention within 8 days after the receipt of the goods, otherwise we will not accept the said claims. Claims do not authorise delays in payment or further price reductions. In case of packing received damaged, the Buyer must inform the forwarder immediately, and send a copy to us for information.

PAYMENT TERMS

Invoices are payable in the currency specified in the invoice.

Payments must be remitted within the agreed expiry data. We reserve ownership of the goods until the invoice and any accessory expenses have been fully paid. Failure by the Buyer to pay by the due date automatically gives rise to interest, giving us the right to deem the contract cancelled because of such failure, unless we prefer to ask for settlement of the amount due, by recourse to law if necessary, with bank interest and damages added. If the Buyer stops a payment, the outstanding amount becomes immediately due and we will file a petition for bankruptcy.

Interest on arrears: in the case of delayed payments, interest on arrears will be calculated at the rate of 7 (seven) points above the official rate of discount of the Banca d'Italia in force at the time such interest was applied.

WARRANTY

All the products supplied by us are guaranteed against construction faults or defects of material for 24 months from the date of delivery, the term by which we shall repair the faulty parts in order to restore correct operation of the appliances. We do not accept any responsibility for direct or indirect damage caused by the use of the said appliances. Any return of material must be requested from us in writing, must reach us free our works and will be re-turned ex our works.

The guarantee is restricted exclusively to the repair at our plant, of appliances acknowledged to be defective, whereas all other costs of transport or labor for technical operations on the appliances are charged to the Buyer. The guarantee is voided if the appliances are found to have been tampered with or dismantled.

If interventions on appliances not considered to be under guarantee are requested, we reserve the right to debit the Buyer for management of the return € 40,00 spare parts, manpower etc. not included.

In the event of a dispute, the Buyer accepts that the Bolzano Court of Law is competent and accepts the laws in force in Italy.



eatec®

Eatec srl a Socio Unico - Loc. Förche 20 - I-39040 Sciaves BZ
Tel. +39 0472 055617 - Fax +39 0472 089807 - info@eatec.it - www.eatec.it